

**HOT PRODUCTS** - DOOR STRIKERS, LINE CLAMPS, ETC 3-5

**HEADERS, EXHAUST KITS &**

**TOTAL-LOC BOLTS** 6-7

**CARB MOUNT KITS** 7

**ENGINE KITS FOR:**

<b>AMC*</b> : 232/258 STRAIGHT SIX & V-8'S	8-9
<b>FORD*</b> : FLAT HEADS V-8S	10
- Y-BLOCKS & MODULAR ENGINES - 16, 24, & 32V	11
- SMALL BLOCKS: 260/289/302/302EFI/351W	12-13
- 351C/351M & 400M	13
- BIG BLOCKS: 352/390/406/410/427/428 FE & 429/460	14
<b>GENERAL MOTORS*</b>	
<b>BUICK*</b> : V 6 231 & STRAIGHT 8	15
- BUICK/OLDS/ROVER* 215 & NAILHEADS	16
- 350/400/430/455 V-8	17
<b>CADILLAC*</b> : 331 THRU 500	18
<b>CHEVY*</b> : STRAIGHT SIX'S 194 THRU 292	19
- LS 1/6, 2.8 & 4.3L V 6	20
- SMALL BLOCKS: 265/283/305/307/327/350/400	21-22
- BIG BLOCKS: 348/409 396-454 502-572	23
<b>OLDSMOBILE*</b> - 260 THRU 455 & ROCKET*	24
<b>PONTIAC*</b> : 287 - EARLY 389 & 350 THRU 455	25
- OVERHEAD CAM 6 CYLINDER	28
<b>INTERNATIONAL*</b> : 304/345/392	25
<b>MOPAR*</b> : SMALL BLOCKS: 273/318/340/360	26
- BIG BLOCKS: 383/413/426/440	26
- EARLY HEMIS*	27
- 426 HEMI* AND LATE MODEL HEMIS*	28
- SLANT SIX	28
<b>VOLKSWAGEN*</b>	72
<b>HARLEY* V-TWINS</b>	74



**DRIVELINE KITS:**

- TRANSMISSIONS AND BELLHOUSING	29-30
- REAR END COVERS	31

**BODY & CHASSIS KITS FOR:**

<b>AFTERMARKET CHASSIS KITS:</b>	32-33
<b>BUICK*</b> 1970-72 GS	33
<b>CADILLAC*</b> 1955 CONVERTIBLES & SEDANS, 1959 COUPE:	34
<b>CHEVROLET*</b> - 1940-54	35
- 1955-57 FULL SIZE	35-36
- CHEVY* FULL SIZE CARS (1958-68) & (1991-1996)	36-38
- CAMARO* & FIREBIRD*	39-40
- CHEVELLE*/EL CAMINO* & MALIBU*	41-43
- CORVAIR*	43
- CORVETTE* 1953-1976	44-45
- NOVA* & CHEVY II*	46-47
- CHEVY* FULL SIZE PICKUPS 1941-1998	48-54
- CHEVY* S-10, GMC* S-15 & SYCLONE*	55
<b>PONTIAC*</b> - GTO* & LEMANS*	56
<b>FORD*</b> - MODEL 'A' & 1932 ROADSTER	57
- 1939 DELUXE*, 1940 COUPE - THRU 1948	58
- 1949 THRU 1956	59
- FALCON* 1960-65	3
- FAIRLANE* & THUNDERBIRD*	60
- FORD MUSTANG* (1964 1/2 - 70) & (1978-93)	61-62
- FORD* FULL SIZE PICKUPS 1940-1991	63-67
- FORD BRONCO* (1966-77) BRONCO II* & RANGER*	68
- FORD BRONCO* 1978-79	67
<b>JEEP*</b> - CJ* & WRANGLER*	69-70
<b>MOPAR*</b> - 1966-69 B BODY & 1970-74 E BODY	3
<b>NASH* METRO &amp; SUNBEAM* TIGER</b>	71
<b>VOLKSWAGENS*</b> (AIR COOLED)	72-73
<b>HARLEY*</b> - V-TWINS	74-75

**METRIC FASTENERS**

- SIX POINT (HIGH STRENGTH)	78
- TWELVE POINT (HIGH STRENGTH)	79

**CAP SCREWS (BOLTS)**

- BUTTON	80
- FLAT SOCKET	81
- HEX	82-83
- SOCKET	84-85

**MACHINE SCREWS**

- SET SCREWS, STUDS, ALL THREAD	86
- CARRIAGE & CHEESE HEAD	87
- FLAT HEAD	88
- OVAL HEAD	89
- PAN HEAD	90

**NUTS & LOCK NUTS**

91-92

**WASHERS - LOCK & FLAT**

92-93

**U.S. FASTENERS**

- SIX POINT (HIGH STRENGTH)	94-96
- TWELVE POINT (HIGH STRENGTH)	97-98
- CARRIAGE BOLTS	99

**CAP SCREWS (BOLTS)**

- BUTTON	100-101
- FLAT SOCKET	102-103
- HEX	104-105
- SOCKET	108-109

**MACHINE SCREWS**

- BLACK OEM STYLE HARDWARE	106
- INDENTED HEX (OEM)	107
- BINDING HEAD	110
- FILLISTER HEAD	110-111
- FLAT HEAD	112-113
- OVAL HEAD	114-115
- PAN HEAD	116-117
- ROUND HEAD	118-119
- TRUSS HEAD	120-121
- SET SCREWS & STUDS	122-123
- SHOULDER BOLTS	124
- THREADED & PLAIN ROD	124
- U-BOLTS & TALL NUTS	125

**NUTS**

126-130

**LOCK NUTS**

131

**WASHERS - LOCK & FLAT**

132-137

- SPACERS (BUSHINGS)	134-135
----------------------	---------

**SHEET METAL SCREWS**

- BUTTON HEAD	101
- FLAT HEAD & DECK SCREWS	138
- HEX & INDENTED HEX	139
- OVAL HEAD & TRIM SCREWS	140
- PAN HEAD	141
- ROUND HEAD	142
- TRUSS HEAD	143

**MISC. HARDWARE**

- ANTI-SEIZE & THREAD GAUGE - INSIDE BACK COVER	
- BRAKE, FUEL LINE CLAMPS & TUBING	4
- PIPE FITTINGS	144-145
- PIPE PLUGS & GREASE ZERKS	146
- EXHAUST & HOSE CLAMPS	147
- RIVETS, SNAPS, & LAG BOLTS	148
- COTTER PINS	149
- POLISHING SUPPLIES	150

**POINT OF PURCHASE DISPLAYS**

151

\*BRAND & MODEL NAMES ARE THE EXCLUSIVE PROPERTY OF THE RESPECTIVE AUTOMAKERS AND ARE USED FOR IDENTIFICATION PURPOSES ONLY!

**- ORDER FORM ON PAGE 152 -**

# TECHNICAL INFORMATION

## U.S. STRENGTH GRADES

STANDARD GRADE STAINLESS (GRADE 2)

70,000 PSI

ARP STAINLESS &amp; TS 17-4 (USE IN PLACE OF GRADE 8)

170,000 PSI

### MAXIMUM TIGHTENING TORQUE (FT. LBS.)

GRADE	1/4-20	1/4-28	5/16-18	5/16-24	3/8-16	3/8-24	7/16-14	7/16-20	1/2-13	1/2-20	9/16-12	5/8-11	5/8-18	3/4-10
2 (18-8)	5	6	11	13	18	20	28	29	39	41	56	83	90	110
8 ARP/TS	9	10	19	20	33	35	57	59	75	78	110	150	170	260

**\*\*ALL TORQUES LISTED ARE FOR FASTENERS LUBRICATED WITH ANTI-SEIZE\*\***

**-NOTE THE TORQUE NEEDED TO FULLY STRESS THE FASTENERS IS SIGNIFICANTLY REDUCED WHEN ANTI-SEIZE IS USED DUE TO LOWER FRICTIONAL LOSSES. AS AN EXAMPLE STAINLESS ARP HEADBOLTS ARE TORQUED TO ONLY 57 FT. LBS. YET WILL PRODUCE THE SAME CLAMPING FORCE AS STANDARD HEADBOLTS WHICH ARE TORQUED TO A MUCH HIGHER VALUE WHEN LUBRICATED WITH OIL.**

## METRIC PROPERTY CLASS (STRENGTH GRADES)

STANDARD GRADE - PROPERTY CLASS 70

100,000 PSI

HIGHER STRENGTH - PROPERTY CLASS 80

118,000 PSI

ARP - HIGH STRENGTH (BETTER THAN METRIC 10.9)

170,000 PSI

### TIGHTENING TORQUE (FT. LBS.)

CLASS	M4-0.7	M5-0.8	M6-1.0	M8-1.25	M10-1.5	M12-1.75
70	1.3	2.5	4.4	10.7	22	37
80	1.7	3.4	5.9	14.2	29	49
ARP			8	20	36	65

**\*\*ALL TORQUES LISTED ARE FOR FASTENERS LUBRICATED WITH ANTI-SEIZE\*\***

**- TO CONVERT FT. LBS. TO NEWTON METERS, MULTIPLY FT. LBS. BY 1.3558 -**

## ANTI-SEIZE COMPOUND

**ANTI-SEIZE IS STRONGLY RECOMMENDED TO PREVENT GALLING, IT IS ESSENTIAL WHEN USING NYLON NUTS OR WHEN THREADING INTO ALUMINUM. WORKING TEMPERATURE OF OUR ANTI-SEIZE IS -65°F TO 1800°F**

3-0022

4 oz. CAN - PLENTY TO COMPLETE YOUR WHOLE PROJECT!

\$8.25

## THREAD LOCKER COMPOUNDS

**PURPLE - LOW TENSION** - WORKS GREAT ON STAINLESS BECAUSE IT ALSO HELPS PREVENT GALLING!

IT'S MADE TO PREVENT VIBRATION LOOSENING OF FASTENERS - NOTE: THIS MATERIAL MAY NOT

WORK IN HIGH TEMPERATURE APPLICATIONS

**24 ML BOTTLE: 3-0023 \$14.80**

**BLUE MEDIUM TENSION BOLT LOCKER**

**3-0024 14.80**

**RED HIGH TENSION (PERMANENT!) BOLT LOCKER**

**3-0025 14.80**

## THREAD SEALER FOR PIPE FITTINGS

WHITE SEALANT - CONTAINS PTFE - 4 OUNCE CAN WITH BRUSH

**3-0029 \$9.99**

## UNIVERSAL THREAD GAUGE

GREAT FOR MEASURING BOTH U.S. (COARSE & FINE) AND METRIC THREADS. THIS GAUGE HAS PROVISIONS TO

MEASURE BOTH EXTERNAL THREADS AND NUTS (U.S. ONLY)

**8-0000 \$4.50**

- THIS CATALOG SUPERSEDES ALL PREVIOUS CATALOGS. WE MAKE A MAJOR EFFORT NOT TO CHANGE PRICES, BUT AS WITH ALL BUSINESSES, PRICES ARE SUBJECT TO CHANGE.

TOTALLY STAINLESS GUARANTEES THE PACKAGED KITS WILL FIT AND WORK FOR THE APPLICATION LISTED - PROVIDING THE FASTENERS ARE NOT TORQUED ABOVE THE VALUE LISTED IN THE TIGHTENING TORQUE TABLE AND ANTI-SEIZE COMPOUND IS USED. TOTALLY STAINLESS MAKES NO WARRANTY OF MERCHANTABILITY OR FITNESS FOR ANY PARTICULAR PURPOSE OR ANY OTHER WARRANTY, EXPRESS OR IMPLIED. TOTALLY STAINLESS SELLS COMMERCIAL QUALITY FASTENERS WITH NO REPRESENTATION CONFORMING TO GOVERNMENT OR OTHER SPECIFICATIONS UNLESS SPECIFICALLY STATED.

**WARNING: THIS PRODUCT CAN EXPOSE YOU TO CHEMICALS INCLUDING NICKEL, WHICH IS KNOWN TO THE STATE OF CALIFORNIA TO CAUSE CANCER. FOR MORE INFORMATION GO TO <https://www.p65warnings.ca.gov/>**



# BODY KITS! (FOR THE FOLLOWING):

## 1960-63 FORD FALCON

CUSTOM STYLE - BUTTON & FLAT SOCKET HEAD	# 9-8000	\$ 399.00
ORIGINAL STYLE - INDENTED HEX & PHILLIPS HEAD	9-8002	455.00
ORIGINAL STYLE - INDENTED HEX WITH BLACK STAINLESS	9-8003	470.00

## Convertible

## Hard Top / Sedan

9-8050	\$ 375.00
9-8052	451.00
9-8053	466.00

## 1964-65 FORD FALCON Hard Top / Sedan

CUSTOM STYLE - BUTTON & FLAT SOCKET HEAD	# 9-8103	\$ 335.50
ORIGINAL STYLE - INDENTED HEX & PHILLIPS HEAD	9-8105	421.50
ORIGINAL STYLE - INDENTED HEX WITH BLACK STAINLESS	9-8106	436.00

## 1964

## 1965

9-8150	\$ 315.50
9-8152	405.00
9-8153	425.00

## 1964 FORD GALAXIE

CUSTOM STYLE - BUTTON & FLAT SOCKET HEAD	# 9-6301	\$ 370.00
ORIGINAL STYLE - HEX & SLOTTED HEAD	9-6302	395.00

## 1935-36 FORD PICK UP

CUSTOM STYLE - BUTTON & FLAT SOCKET HEAD	# 9-4600	\$ 285.00
ORIGINAL STYLE - HEX & SLOTTED HEAD	9-4601	275.00

## 1970-74 MOPAR E-BODY (BARRACUDA & DODGE CHALLENGER)

CUSTOM STYLE - BUTTON & FLAT SOCKET HEAD	# 9-0500	\$ 320.00
ORIGINAL STYLE - INDENTED HEX & PHILLIPS HEAD	9-0501	445.00
ORIGINAL STYLE - INDENTED HEX WITH BLACK STAINLESS	9-0502	460.00
CHASSIS KIT: FRONT & REAR SUSPENSION - 6 POINT	9-0590	1408.00

## MOPAR B BODY - SATELLITE, ROAD RUNNER' ETC.

CUSTOM STYLE - BUTTON & FLAT SOCKET HEAD	# 9-0700	\$ 315.00	1966-1967	1968-69
ORIGINAL STYLE - INDENTED HEX, HEX & PHILLIPS HEAD	9-0702	405.50	9-0801	\$345.00
			9-0803	455.00

# STUD BOLTS:

- ANY COMBINATION OF THREADS
- COARSE, FINE THREAD - OR BOTH
- 3/16 THRU 3/4" DIA. IN 303 (LOW STRENGTH)
- 3/8" THRU 3/4" DIAMETERS ALSO AVAILABLE IN 17-4 PH HEAT TREATED HIGH STRENGTH
- ALSO AVAILABLE WITH FLANGED NUTS

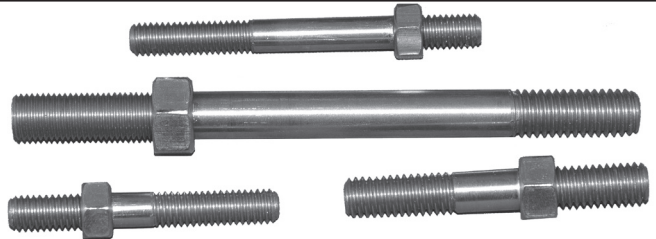

## HIGH STRENGTH BUTTON HEADS - AS STRONG OR STRONGER THAN GRADE 8 STEEL



WE CAN TURN THE HEADS AND BROACH HEX DRIVES IN OUR HIGH STRENGTH 6 OR 12 POINT BOLTS TO MAKE BUTTON HEADS.

HIGH STRENGTH 6 AND 12 POINT BOLTS ARE AVAILABLE IN A WIDE RANGE OF SIZES FROM 1/4" THRU 3/4" DIAMETERS (6 THRU 12MM TOO) SEE PAGES 78,79,94-98 FOR SIZE SELECTION.

THE PRICE TO RECUT & BROACH THE HEADS IS:

1/4" (OR 6MM)	ADD \$12 PER BOLT
5/16" , 3/8" (OR 8MM)	13 " "
7/16 (OR 10MM)	14 " "
1/2" (OR 12MM)	15 " "
9/16"	16 " "
5/8"	17 " "
3/4"	19 " "

3/8-24, 7/16-20 & 9/16-12 PICTURED ABOVE - THESE ARE NOT STOCKED - MADE TO ORDER FOR USE IN SHEAR ONLY - BUTTON HEADS ARE NOT TO BE USED IN TENSION



# HOT PRODUCTS - ALL MADE IN USA & AUSTRALIA!

## BRAKE & FUEL LINE CLAMPS

- MADE IN USA

- ALL CLAMPS MADE FROM 13 GA (.092) 18-8 STAINLESS

- I.D. OF BOLT HOLE IS 13/64" (.204)  
\* USE #10 SCREWS \*

- PARTS ARE FREE FROM BURRS AND HAVE A BRIGHT FINISH

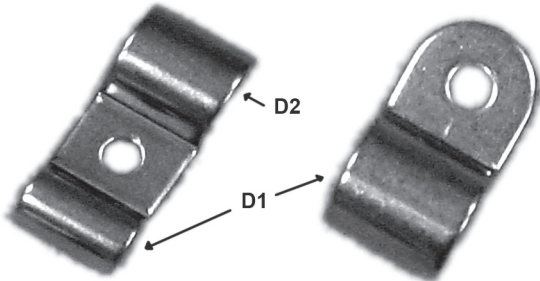

PART#	\$	D1	D2	W	APPLICATION
7-0500	4.25	3/16		.62	BRAKE LINE
7-0501	5.00	1/4		.62	BRAKE LINE
7-0502	5.25	5/16		.66	FUEL/TRANS.
7-0503	5.50	3/8		.66	FUEL LINE
7-0504	6.00	1/2		.72	BATTERY CABLE
<b>- DOUBLE LINE CLAMPS -</b>					
7-0510	7.00	3/16	3/16	.76	BRAKE LINE
7-0511	7.05	3/16	1/4	.76	BRAKE LINE
7-0513	7.15	3/16	3/8	.76	BRAKE/FUEL
7-0514	7.95	1/4	1/4	.76	BRAKE LINE
7-0515	8.85	1/4	3/8	.76	BRAKE/FUEL
7-0518	9.60	5/16	5/16	.76	TRANS./FUEL
7-0516	10.50	5/16	3/8	.76	FUEL LINE
7-0517	11.25	3/8	3/8	.76	FUEL LINE
7-0519	12.00	1/2	1/2	.82	BATTERY CABLE

### BACKING PLATES FOR DOUBLE CLAMPS: TAPPED 10-32

FOR 3/16 X 3/16, 3/16 X 1/4 & 1/4 X 1/4 CLAMPS (1 3/8" LONG):	# 7-0536	\$ 6.95
1/4 X 3/8, 5/16 X 5/16, 5/16 X 3/8 & 3/8 X 3/8 (1 5/8" LONG):	7-0537	7.25
FOR 1/2 X 1/2 CLAMPS (1 7/8" LONG):	7-0538	7.50

## AIR CLEANER NUTS

SIZE	O.D.	PART #	\$
1/4-20	1"	2-4565	20.00
	1 1/4	2-4501	25.00
5/16-18	1"	2-4566	20.00
	1 1/4	2-4503	25.00

NOTE: MOST CARBS HAVE A 1/4-20 STUD

POLISHED! CUSTOM MADE IN OUR SHOP

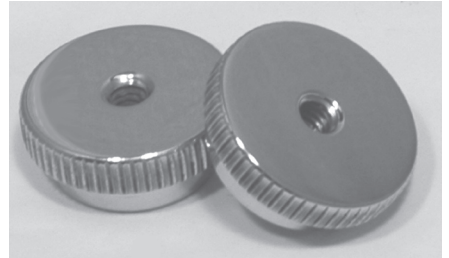

## BRAKE LINE CLIPS

- MADE IN AUSTRALIA

- FOR ATTACHING FLEXIBLE BRAKE LINE TO BRACKETS



# 2-4500 \$ 3.50



BRACKET FOR CLIP  
# 2-4700 \$ 2.99

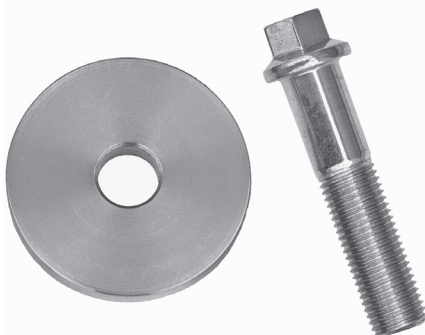

## HARMONIC BALANCER KITS

- HIGH STRENGTH (GRADE 8+) STAINLESS BOLTS
- STAINLESS CUSTOM MADE OEM SIZE THICK BILLET WASHERS

AVAILABLE FOR:

AMC V8 & STRAIGHT SIX - PAGE 9	331-390 CADILLAC - PAGE 18
FORD MODULAR - PAGE 11	SMALL BLOCK CHEVY - PAGE 22
FORD SMALL BLOCK - PAGE 13	BIG BLOCK CHEVY - PAGE 24
FORD FE BIG BLOCK - PAGE 14	INTERNATIONAL V8 - PAGE 26
FORD 429/460 - PAGE 14	OLDS 260-455 - PAGE 24
215 BUICK/OLDS - PAGE 16	OLDS ROCKET - PAGE 25
455 BUICK - PAGE 17	PONTIAC V8 - PAGE 26
	EARLY HEMI - PAGE 29

## DOOR STRIKER BOLTS & WASHERS - 17-4 PH HIGH STRENGTH - WEAR RESISTANT PINS WITH CORRECT HEAVY DUTY STAINLESS WASHERS -

**\*\* NOTE #6-8154 & 6-8149 ARE STOCKED ITEMS - ALL OTHER STRIKERS ARE MADE TO ORDER \*\***



FOR AMX, GREMLIN & JAVELIN (1/2-13 THREAD): 8-8000 \$ 75.00 PER PAIR  
 FOR 1967-69 CAMARO, 1964-72 GM A-BODIES, 1965-72 FULL SIZE,  
 1968-74 NOVA, 68-82 VETTE & 73 & UP AMC: 6-8154 59.95 PER PAIR  
 FOR 1970-92 CAMARO, 1978-87 GM MID & FULL SIZE, 1975-79 NOVA, 1984-93  
 S-10 & 1988-98 CHEVY/ GMC C/K TRUCKS & SUV: 6-8149 65.00 PER PAIR  
 FOR 1965-66 CORVAIR: 6-8148 85.75 PER PAIR  
 FOR 1985-95 CHEVY VAN: 6-8179 85.75 PER PAIR  
 FOR 1970-74 DODGE CHALLENGER: 9-0599 95.50 PER PAIR  
 FOR 1967-72 FORD PICKUP: 6-6199 95.50 PER PAIR  
 FOR 1973-79 FORD PICKUP & 1978-79 BRONCO: 6-6217 95.50 PER PAIR  
 FOR 1971-73 MUSTANG: 9-7100 95.25 PER PAIR  
 1983-94 MUSTANG: 6-0449 95.50 PER PAIR  
 FOR 1982-86 CJ & 87-95 WRANGLER: 6-2098 80.75 PER PAIR  
 FOR 1970-74 MOPAR CHALLENGER & BARRACUDA: 9-0599 95.50 PER PAIR

- 1/16 THICK (.05) X 1-1/2 OD SPACER WASHER FOR ALL OF THE ABOVE 2-4973 6.50 EACH  
 - 1/8 THICK X 1-1/2 OD SPACER WASHER FOR ALL OF THE ABOVE 2-4427 8.50 EACH

FOR 1973-87 CHEVY/GMC TRUCKS & SUBURBANS, 1973-77 GM MIDSIZE, & 1971-77 FULL SIZE:  
 THE SHOULDER OD IS LARGER THAN STOCK TO ELIMINATE THE PLASTIC SHELL - 6-7766 95.50 PER PAIR

- 1/16 THICK (ACTUALLY .05) SPACER WASHER FOR ABOVE (1/2" ID) 2-4994 6.50 EACH  
 - 1/8 THICK SPACER WASHER FOR ABOVE 2-4907 8.50 EACH

FOR 'SMALL BEAR CLAW' LATCH: 1/2 X .69 X 3/8-16 THREAD 6-8159 75.50 PER PAIR  
 1/2 X .88 X 3/8-16 (EXTRA LONG SHANK) 6-9887 80.75 PER PAIR

FOR 'LARGE BEAR CLAW' LATCHES: 7/16-14 THREAD - MEASURE & SELECT FROM TABLE, WASHERS INCLUDED

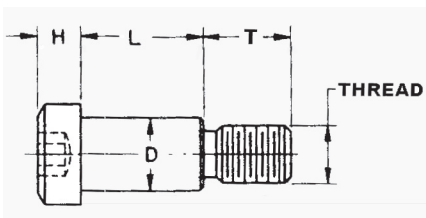

D	L	HEAD O.D.	T	H	WASHER OD	PART #	PRICE
.550	.63	.75	1.5	.16	1.0	6-8175	\$ 92.50
.550	.70	.75	.88	.16	1.17	6-8176	91.50
.550	.81	.75	1.5	.13	1.0	6-8178	97.75
.550	.85	.75	1.0	.13	1.17	6-8184	92.50
.560	.75	.75	1.0	.16	1.17	6-8177	91.50
.625	.75	.75	1.0	.13	1.0	6-8160	91.50
.625	.87	.75	1.0	.18	1.0	6-8187	92.75
.675	.69	.75	.88	.16	1.0	6-8166	92.50
.675	.85	.75	1.0	.18	1.0	6-8173	92.50
.675	1.00	.75	.94	.13	1.0	6-8174	92.75

**\*\* NEED A SPECIAL SIZE? WE CAN MAKE THESE FOR NEARLY ANY APPLICATION - SPECIFY DIMENSIONS SHOWN AND WASHER O.D. \*\***

### SPECIALTY CARRIAGE BOLTS

THE 0.6 X .95 OVAL HEAD BOLTS ARE 7/16-14 ALL OF THE OTHERS ARE 12MM THREADS (USE IN PLACE OF BOLTS WITH 7/16 THREAD -ORDER 12MM NUTS TO MATCH ON PAGE 91. POLISHED TO A MIRROR FINISH MADE TO ORDER IN OUR SHOP!

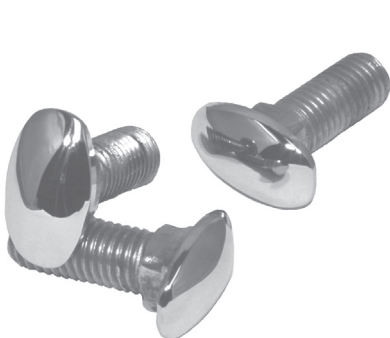

### OVAL HEAD:

0.6 WIDE X .95 LONG (FOR CROSLEY)  
 2-7741P \$22.25 EACH  
 6-9988 SET OF (4) WITH NUTS & FLATS: 95.00

### 0.7 WIDE X 1.12 LONG HEAD

1-1802 1-1/4" LONG \$20.00 EACH  
 1-1800 1-3/8" LONG 21.00  
 1-1805 2" LONG 22.00

5-9999 SET OF (4) 1-3/8" LONG WITH NUTS & FLAT WASHERS: \$88.00

### CURVED RECTANGULAR HEAD:

15/16 WIDE X 1 1/16 LONG - FOR 1949-50 MERCURY  
 1-1801 \$35.50 EACH  
 5-9998 SET OF (4) WITH NUTS & FLATS: \$145.00





- ALL HEADER KITS (EXCEPT STOCK STYLE HEX KITS CONTAIN HIGH STRENGTH BOLTS
- USE 3/4" LENGTH BOLTS FOR HEADER FLANGES 1/4" THICK OR LESS
- USE 1" LENGTH BOLTS FOR HEADER FLANGES OVER 1/4" THICK.
- 1 1/4" AND 1 1/2" LENGTH BOLT KITS ARE FOR CAST IRON MANIFOLDS, CHECK YOUR ORIGINAL BOLT LENGTHS BEFORE ORDERING, SOME EXHAUST MANIFOLDS USED SEVERAL BOLT LENGTHS.

### 10 COUNT 3/8" HEADER BOLT KITS

-FOR OLDSMOBILE V8, INTERNATIONAL V8

#### -3/4" LONG BOLTS

SIX POINT - HIGH STRENGTH	# 6-5360	\$ 47.50
TWELVE POINT - HIGH STRENGTH	6-5361	49.50

#### -7/8" LONG BOLTS - DRILLED FOR SAFETY WIRE \*

SIX POINT - HIGH STRENGTH	6-5388	62.00
TWELVE POINT - HIGH STRENGTH	6-5389	65.00

#### -1" LONG BOLTS

SIX POINT - HIGH STRENGTH	6-5362	59.50
TWELVE POINT - HIGH STRENGTH	6-5363	52.50

### 11 COUNT 3/8" HEADER BOLT KITS

-FOR AMC STRAIGHT SIX

#### - 1" LONG BOLTS

SIX POINT - HIGH STRENGTH	6-6611	54.00
TWELVE POINT - HIGH STRENGTH	6-6612	57.50

### 12 COUNT 5/16" HEADER BOLT KITS

-FOR SMALL BLOCK MOPARS - 12PT ARE LARGE FLANGE

#### -3/4" LONG BOLTS

SIX POINT - HIGH STRENGTH	6-3038	49.50
TWELVE POINT - HIGH STRENGTH	6-3039	53.00

#### -7/8" LONG BOLTS - ALL LARGE FLANGE - NOT DRILLED

SIX POINT - HIGH STRENGTH	6-3036	51.00
TWELVE POINT - HIGH STRENGTH	6-3037	55.00

#### -1" LONG BOLTS

SIX POINT - HIGH STRENGTH	6-3090	53.50
TWELVE POINT - HIGH STRENGTH	6-3210	57.00

### 12 COUNT 3/8" HEADER BOLT KITS

-FOR AMC V8 (KIND WITH ALL 3/8" BOLTS), BUICK V6, CHEVY 4.3L V6, SMALL BLOCK V8, 37-48 FORD V8, PONTIAC V8, BIG BLOCK MOPAR & OLDS ROCKET V8

#### -3/4" LONG BOLTS

SIX POINT - HIGH STRENGTH	6-5060	57.00
TWELVE POINT - HIGH STRENGTH	6-5061	59.50

#### -7/8" LONG BOLTS - DRILLED FOR SAFETY WIRE \*

SIX POINT - HIGH STRENGTH	6-5098	74.50
TWELVE POINT - HIGH STRENGTH	6-5099	78.00

#### -1" LONG BOLTS

SIX POINT - HIGH STRENGTH	6-5062	59.00
TWELVE POINT - HIGH STRENGTH	6-5063	63.00

#### -1 1/2" LONG BOLTS - STOCK EXHAUST FOR AMC:

HEX HEAD - HAS STOCK APPEARANCE	6-3400	15.00
SIX POINT - HIGH STRENGTH	6-3403	87.00
TWELVE POINT - HIGH STRENGTH	6-3404	89.50

\* .032 SAFETY WIRE: 2-9900 \$ .35/FT (10 FT MIN)

**SEE NEXT PAGE FOR  
COLLECTOR FLANGE KITS**

**TOLL FREE ORDER LINE : 1-800-767-4781**

### 14 COUNT 3/8" HEADER BOLT KITS

-FOR BUICK V8, 348-409, FORD Y-BLOCK, & EARLY HEMI

#### -3/4" LONG BOLTS

SIX POINT - HIGH STRENGTH	# 6-0953	\$ 66.50
TWELVE POINT - HIGH STRENGTH	6-0954	69.00

#### -7/8" LONG BOLTS - DRILLED FOR SAFETY WIRE \*

SIX POINT - HIGH STRENGTH	6-0955	86.50
TWELVE POINT - HIGH STRENGTH	6-0956	91.00

#### -1" LONG BOLTS

SIX POINT - HIGH STRENGTH	6-0957	68.50
TWELVE POINT - HIGH STRENGTH	6-0958	73.70

#### -1 1/4" LONG BOLTS - FOR STOCK EXHAUST: FORD TRUCK Y-BLOCK (USE 1" FOR T-BIRD) AND EARLY HEMI

HEX HEAD -HAS STOCK APPEARANCE	6-0992	17.00
SIX POINT - HIGH STRENGTH	6-0993	74.00
TWELVE POINT - HIGH STRENGTH	6-0960	77.50
STUDS & HEX NUTS	6-3396	139.00

### 16 COUNT 3/8" HEADER BOLT KITS

FOR CADILLAC, BIG BLOCK (394 TO 572) CHEVY, 426 HEMI, 215 BUICK/OLDS, BUICK NAILHEAD, FORD 289-351, 351-400 C/M, FE, & 429/460.

#### -3/4" LONG BOLTS

SIX POINT - HIGH STRENGTH	6-5141	75.50
TWELVE POINT - HIGH STRENGTH	6-5142	79.00

#### -7/8" LONG BOLTS - DRILLED FOR SAFETY WIRE \*

SIX POINT - HIGH STRENGTH	6-5182	99.00
TWELVE POINT - HIGH STRENGTH	6-5183	104.50

#### -1" LONG BOLTS

SIX POINT - HIGH STRENGTH	6-5143	78.50
TWELVE POINT - HIGH STRENGTH	6-5144	84.00

#### -1 1/4" LONG BOLTS - STOCK EXHAUST FOR BIG BLOCK CHEVY, FORD 351C, 351/400M.

HEX HEAD - HAS STOCK APPEARANCE	6-5695	20.00
INDENTED HEX WASHER (STOCK FOR BBC)	6-5188	61.50
SIX POINT - HIGH STRENGTH	6-5150	84.50
TWELVE POINT - HIGH STRENGTH	6-5151	88.50

### 8MM BOLT HEADER KITS

12 COUNT: FOR SOME CHEVY LS ENGINES

SOCKET HEAD - A4-80	5-1537	22.00
SIX POINT - HIGH STRENGTH	5-1538	72.50
TWELVE POINT - HIGH STRENGTH	5-1539	73.00

16 COUNT: FOR SOME CHEVY LS1/6, FORD MOD V8'S & NEW HEMIS

SOCKET HEAD	5-1526	27.00
SIX POINT - HIGH STRENGTH	5-1540	95.00
TWELVE POINT - HIGH STRENGTH	5-1541	96.50

### BALL END STUDS WITH 12 POINT NUTS

#### 3/8-16/24 (7/16 WRENCH SIZE)

10 COUNT	6-9995	161.00
11 COUNT	6-9989	177.00
12 COUNT	6-9996	193.00
14 COUNT	6-9997	225.00
16 COUNT	6-9998	256.50

#### 8MM (10 MM WRENCH SIZE)

12 COUNT (FOR SOME LS)	5-1610	242.50
16 COUNT (SOME LS & FORD MODULAR)	5-1611	322.50
17 COUNT (FOR NEW HEMI)	5-1612	343.00
20 COUNT (FOR FORD V-10)	5-1613	405.00

# TOTAL-LOC® LOCKING HEADER BOLTS

**TOTAL-LOC® HEADER BOLTS - .53 FLANGE - - VIBRATION PROOF, HEAT RESISTANT, LOCKING HIGH STRENGTH STAINLESS HEADER BOLTS THAT ARE EASY TO USE!**

**3/8" WRENCH HEAD: SIX POINT - 3/8-16 x 1" - BEST SELLER!**

10 COUNT	# 6-5573	\$ 89.99
11 COUNT	6-6971	99.99
12 COUNT	6-5586	110.00
14 COUNT	6-5574	128.50
16 COUNT	6-5599	147.00

**TWELVE POINT - 3/8-16 X 1"**

10 COUNT	# 6-5581	\$ 89.99
11 COUNT	6-6912	99.99
12 COUNT	6-5582	110.00
14 COUNT	6-5583	128.50
16 COUNT	6-5584	147.00

**5/16" WRENCH HEAD: SIX POINT - 3/8-16 x 1" - FOR EXTRA CLEARANCE**

10 COUNT	# 6-6950	\$ 89.90
11 COUNT	6-6973	98.85
12 COUNT	6-6951	107.85
14 COUNT	6-6952	125.85
16 COUNT	6-6953	143.80



**3/8" WRENCH HEAD: SIX POINT - 3/8-16 X 1 1/4"**

10 COUNT	# 6-6954	\$ 89.99
11 COUNT	6-6955	99.99
12 COUNT	6-6956	110.00
14 COUNT	6-6957	128.50
16 COUNT	6-6958	147.00

**8MM BOLTS & SEPARATE WEDGE LOCKS**

**12 COUNT: (FOR SOME LS ENGINES)**

SIX POINT	# 5-1546	\$ 105.50
TWELVE POINT	5-1547	107.00
SOCKET (A4-80)	5-1548	47.50

**16 COUNT: (FOR SOME LS & FORD MODULAR)**

SIX POINT	# 5-1542	\$ 140.00
TWELVE POINT	5-1543	142.00
SOCKET (A4-80)	5-1544	62.50

**17 COUNT: (FOR NEW HEMIS)**

SIX POINT	# 5-1590	\$ 148.50
TWELVE POINT	5-1591	150.00
SOCKET (A4-80)	5-1592	66.00

**20 COUNT: (FOR FORD V-10)**

SIX POINT	# 5-1600	\$ 174.50
TWELVE POINT	5-1601	176.00
SOCKET (A4-80)	5-1602	77.50

**5/16-18 X 1 BOLTS WITH SEPARATE WEDGE LOCKS**

**TWELVE COUNT (FOR SMALL BLOCK MOPAR)**

SIX POINT	# 6-3248	\$ 82.00
-----------	----------	----------

TWENTY COUNT (FOR MOPAR V-10)	# 6-3260	\$ 135.50
-------------------------------	----------	-----------



**3/8-16/24 BALL END STUDS, WEDGE LOCK WASHERS, AND 12 POINT NUTS**

10 COUNT (SHOWN)	# 6-9990	\$ 191.50
11 COUNT	6-9994	210.50
12 COUNT	6-9991	229.50
14 COUNT	6-9992	267.00
16 COUNT	6-9993	305.00

**STUD KIT FOR CUMMINS 6 CYL DIESEL:**

**10 X 55 MM STUDS, WEDGE LOCK WASHERS, & NUTS**

WITH HEX NUTS	# 9-0600	\$ 281.50
WITH 12PT NUTS	9-0601	431.00

**8MM BALL END STUDS & WEDGE LOCKS**

**AND 12 POINT NUTS (10 MM WRENCH SIZE)**

12 COUNT (FOR SOME LS)	# 5-1604	\$ 270.50
16 COUNT (FOR SOME LS & FORD MODULAR):		
	5-1605	360.00
17 COUNT (FOR NEW HEMI)	5-1607	382.50
20 COUNT (FOR FORD V-10)	5-1603	449.50

**COLLECTOR FLANGE KITS :**

**3 BOLT TYPE:**

INCLUDES SERRATED FLANGE NUTS & SPLIT LOCKS:		
HEX HEAD	# 6-6600	\$ 11.50
SOCKET HEAD	6-6601	12.00
SIX POINT - HIGH STRENGTH	6-6602	37.00
TWELVE POINT - HIGH STRENGTH	6-6603	38.50

**4 BOLT TYPE:**

# 6-6604	\$14.75
6-6605	15.00
6-6606	49.00
6-6607	51.00



**COLLECTORS KITS WITH WEDGE LOCK WASHERS:**

**INCLUDES NUTS & VIBRATION PROOF WEDGE LOCKS (SHOWN HERE):**

SIX POINT - HIGH STRENGTH	6-6608	77.50	6-6610	102.25
TWELVE POINT - HIGH STRENGTH	6-6609	79.50	6-6613	104.00

**CARB MOUNT KITS (BOLTS TO MANIFOLD)**

**- FOR HOLLEY, CARTER, ETC. 4 BARREL CARBS**

BUTTON HEAD	# 6-5055	\$ 5.00
INDENTED HEX HEAD	6-6399	13.50
HEX HEAD	6-5053	5.50
SOCKET HEAD	6-5054	5.50
SIX POINT - HIGH STRENGTH	6-5178	18.75
TWELVE POINT - HIGH STRENGTH	6-5179	19.25
STUDS & FLANGED NUTS	6-5170	6.75
ARP STUDS & 12 POINT NUTS	6-5275	60.00

**- FOR QUADRAJET CARBS**

HEX HEAD	# 6-5295	\$ 8.00
SOCKET HEAD	6-5296	9.50
SIX POINT - HIGH STRENGTH	6-5297	26.00
TWELVE POINT - HIGH STRENGTH	6-5294	28.50

**- CARB KIT FOR HOLLEY 94 (UP TO 1954) CARBS (27 PIECE ASSEMBLY KIT)**

FILLISTER HEAD ORIGINAL STYLE	6-5292	15.50
-------------------------------	--------	-------

**FLOAT BOWL KITS FOR HOLLEYS**

-FOR FLOAT BOWLS WITHOUT A METERING BLOCK:  
-FOR FLOAT BOWLS WITH A METERING BLOCK

SIX POINT - HIGH STRENGTH	# 6-5298	\$ 23.00
SIX POINT - HIGH STRENGTH	6-5299	24.00



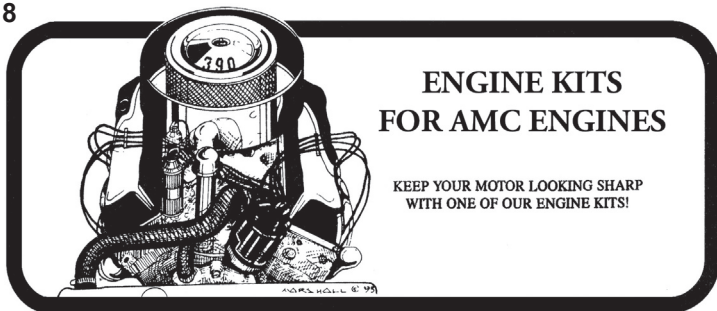

## ENGINE KITS FOR AMC ENGINES

KEEP YOUR MOTOR LOOKING SHARP  
WITH ONE OF OUR ENGINE KITS!

# ENGINE KITS FOR AMC 232-258 STRAIGHT SIX

Each engine kit includes component kits for the Distributor, Fuel Pump, Intake - high strength bolts are used in all intake kits, Oil Pan, Thermostat, Timing Cover, Valve Cover (cast aluminium or sheet metal), and Water Pump. Over 115 pieces and available in 5 different bolt styles!

Contains one of each component kit	Part # for Engines With a Cast Valve Cover:	Part # for Engines with a Sheet Metal Valve Cover:	Price:
<b>232-258 UP THROUGH 1980:</b>			
BUTTON HEAD	# 6-3568	# 6-3500	\$ 109.75
INDENTED HEX (ORIGINAL STYLE)	6-3554	6-3592	140.50
SOCKET HEAD	6-3570	6-3502	110.75
SIX POINT - POLISHED - HIGH STRENGTH	6-3571	6-3503	297.50
TWELVE POINT - POLISHED - HIGH STRENGTH	6-3572	6-3504	319.50
<b>258 1981 THROUGH 1986:</b>			
BUTTON HEAD	# 6-3575	# 6-3580	\$ 105.75
HEX HEAD	6-3576	6-3581	103.00
INDENTED HEX (ORIGINAL STYLE)	6-3593	6-3594	131.00
SOCKET HEAD	6-3577	6-3582	108.00
SIX POINT - POLISHED - HIGH STRENGTH	6-3578	6-3583	287.00
TWELVE POINT - POLISHED - HIGH STRENGTH	6-3579	6-3584	311.00
<b>243(4.0L) &amp; 258(4.2L) 1987-1990: 122 PIECES!</b>			
BUTTON HEAD	# 6-3700		\$ 109.00
HEX HEAD	6-3701		105.00
INDENTED HEX (ORIGINAL STYLE)	6-3702		148.00
SOCKET HEAD	6-3703		110.00
SIX POINT - POLISHED - HIGH STRENGTH	6-3704		313.00
TWELVE POINT - POLISHED - HIGH STRENGTH	6-3705		340.50
<b>243(4.0L) 1991 &amp; UP: 129 PIECES!</b>			
BUTTON HEAD	# 6-3730		\$ 110.00
INDENTED HEX (ORIGINAL STYLE)	6-3732		157.00
SOCKET HEAD	6-3733		112.00
SIX POINT - POLISHED - HIGH STRENGTH	6-3734		351.50
TWELVE POINT - POLISHED - HIGH STRENGTH	6-3735		380.50

\*\* NOTE INDENTED HEX, SIX POINT & TWELVE POINT BOLTS ARE MADE IN USA \*\*

## ACCESSORY KITS (NOT INCLUDED IN THE ENGINE KIT)

### ALTERNATOR BRACKET FOR CJ'S

BUTTON HEAD	# 6-3555	\$ 9.75
HEX HEAD	6-3550	8.00
SOCKET HEAD	6-3551	10.00
SIX POINT - HIGH STRENGTH	6-3552	32.00
TWELVE POINT - HIGH STRENGTH	6-3553	33.50

### BELLHOUSING KITS: T4&5 TRANSMISSIONS

SIX POINT - HIGH STRENGTH	6-3736	89.50
TWELVE POINT - HIGH STRENGTH	6-3737	92.50

### COIL BRACKET KITS

BUTTON HEAD	6-3544	4.00
INDENTED HEX - ORIGINAL STYLE	6-3546	5.50
SOCKET HEAD	6-3547	4.00
SIX POINT - HIGH STRENGTH	6-3548	11.00
TWELVE POINT - HIGH STRENGTH	6-3549	11.50

### CRANK PULLEY KITS

SIX POINT - HIGH STRENGTH	6-3542	15.50
TWELVE POINT - HIGH STRENGTH	6-3543	16.00

### HARMONIC BALANCER KIT FOR SIX CYL.

SIX POINT - HIGH STRENGTH	6-3558	26.50
---------------------------	--------	-------

**EXHAUST BOLT KITS - INCLUDED IN ENGINE  
KITS FOR STOCK EXHAUST - FOR HEADERS  
SEE 11 COUNT KITS ON PAGES 6-7**

### ENGINE MOUNT KIT - (Brackets to the Engine)

FOR SHEET METAL TYPE MOUNTS:		
SIX POINT - HIGH STRENGTH	# 6-3559	\$ 29.50
TWELVE POINT - HIGH STRENGTH	6-3560	32.00
FOR CAST TYPE MOUNTS:		
SIX POINT - HIGH STRENGTH	6-3556	33.50
TWELVE POINT - HIGH STRENGTH	6-3557	35.00

### OIL PUMP KITS

SIX POINT - HIGH STRENGTH	6-3746	14.50
TWELVE POINT - HIGH STRENGTH	6-3747	15.50

### STARTER KITS

HEX HEAD	6-3744	5.50
SOCKET HEAD	6-3745	7.75
SIX POINT - HIGH STRENGTH	6-3742	17.00
TWELVE POINT - HIGH STRENGTH	6-3743	18.00

### TRANSMISSION TO BELLHOUSING: T4&5

SIX POINT - HIGH STRENGTH	6-3738	37.00
TWELVE POINT - HIGH STRENGTH	6-3739	38.50

### TRANSFER CASE TO TRANSMISSION: T4&5

SIX POINT - HIGH STRENGTH	6-3740	28.00
TWELVE POINT - HIGH STRENGTH	6-3741	29.00

# ENGINE KITS FOR AMC V-8 304- 360- 390- 401

Each engine kit includes component kits for the Distributor, Fuel Pump, Intake, Oil Pan, Thermostat, Timing Cover, Valve Covers (cast aluminium or sheet metal), and Water Pump. Over 145 pieces and available in 5 different bolt styles!

Contains one of each component kit	Part # for Engines with Cast Valve Covers	Part # for Engines with Sheet Metal Valve Covers	Price:
BUTTON/SOCKET HEAD	# 6-3464	# 6-3465	\$ 89.50
HEX/INDENTED HEX HEAD (Stock Style)	6-3476	6-3470	126.00
SOCKET HEAD	6-3429	6-3402	99.50
SIX POINT - HIGH STRENGTH - POLISHED	6-3458	6-3466	336.00
TWELVE POINT - HIGH STRENGTH - POLISHED	6-3459	6-3467	380.00

\*\* NOTE INDENTED HEX, SIX POINT & TWELVE POINT BOLTS ARE MADE IN USA \*\*

## ACCESSORY KITS (NOT INCLUDED IN THE ENGINE KIT)

### BELLOUSING KITS

SIX POINT - HIGH STRENGTH	# 6-3479	\$ 68.50
TWELVE POINT - HIGH STRENGTH	6-3480	70.00

### CARB MOUNT KITS - SEE PAGE 7

### CRANK PULLEY KITS - 3 BOLT TYPE

SIX POINT - HIGH STRENGTH	6-3542	15.50
TWELVE POINT - HIGH STRENGTH	6-3543	16.00
<b>- 76 &amp; UP ARE 4 BOLT TYPE</b>		
SIX POINT - HIGH STRENGTH	6-3720	19.50
TWELVE POINT - HIGH STRENGTH	6-3719	20.00

### EXHAUST BOLT KITS -FOR YEARS WITH ALL 3/8" BOLTS

STOCK EXHAUST- 1.5" LONG BOLTS HEX HEAD (Has stock appearance, but is not as strong as stock)	6-3400	15.00
SIX POINT - HIGH STRENGTH	6-3403	87.00
TWELVE POINT - HIGH STRENGTH	6-3404	89.50

**\*FOR HEADERS SEE 12 COUNT KITS ON PAGES 6 & 7\***

### ENGINE MOUNT KITS

SIX POINT - HIGH STRENGTH	6-3468	30.50
TWELVE POINT - HIGH STRENGTH	6-3469	33.50

### HARMONIC BALANCER KIT - V8

SIX POINT - HIGH STRENGTH	6-3482	26.00
---------------------------	--------	-------

### OUTSIDE HEAD BOLTS KIT

**-7/16" BOLTS:**

SIX POINT - HIGH STRENGTH	6-3478	98.00
TWELVE POINT - HIGH STRENGTH	6-3481	103.00

**-1/2" BOLTS:**

SIX POINT - HIGH STRENGTH	6-3483	132.00
TWELVE POINT - HIGH STRENGTH	6-3484	134.50

### POWER STEERING PUMP KITS - KIT WAS MADE FOR A WAGONEER - MAY WORK FOR OTHER APPLICATIONS

BUTTON HEAD	6-3485	13.50
HEX HEAD	6-3486	13.75
SOCKET HEAD	6-3487	14.25
SIX POINT - HIGH STRENGTH	6-3488	40.50
TWELVE POINT - HIGH STRENGTH	6-3489	41.50

### STARTER KITS

BUTTON HEAD	6-3453	5.50
HEX HEAD	6-3454	5.75
SOCKET HEAD	6-3455	6.75
SIX POINT - HIGH STRENGTH	6-3456	13.50
TWELVE POINT - HIGH STRENGTH	6-3457	14.00

### STUD BOLT FOR WATER PUMP (5" UNDER HEAD)

6-3/8" OVERALL LENGTH	2-7120	19.95
-----------------------	--------	-------

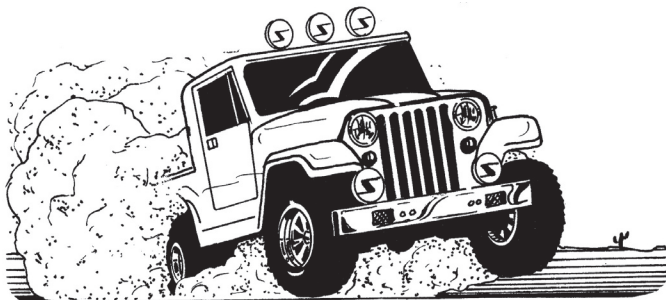

## ENGINE KITS FOR MODEL A's

Each engine kit includes component kits for the Bellhousing, Cylinder head nuts, Distributor, Exhaust manifold, Fan & water pump nuts, Generator, Intake, Oil pan, Oil pump return, Starter, Timing cover (with timing plug), Valve cover & Water inlet 203 pieces and available in 5 different bolt styles!

BUTTON HEAD	# 9-2801	\$ 124.50
HEX HEAD (CLOSEST TO ORIGINAL STYLE)	9-2800	122.00
NOTE: ORIGINAL STYLE HIGH HEX HEADS ARE NOT AVAILABLE AT THIS TIME		
SOCKET HEAD	9-2803	134.00
SIX POINT - POLISHED - HIGH STRENGTH	9-2804	394.00
TWELVE POINT - POLISHED - HIGH STRENGTH	9-2805	395.50

**See page 57 for body kits!**

**NOTE TIMING PLUG AND DISTRIBUTOR SCREW ARE INCLUDED IN ENGINE KITS**

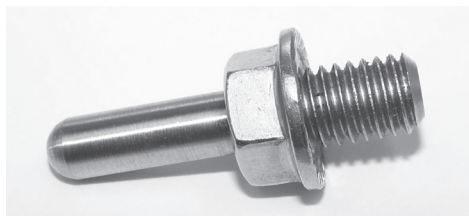

**TIMING PLUG: 2-7199 \$20.00**

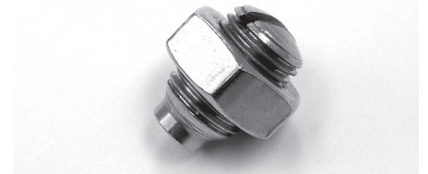

**DISTRIBUTOR SCREW & NUT 9-2812 \$13.00**

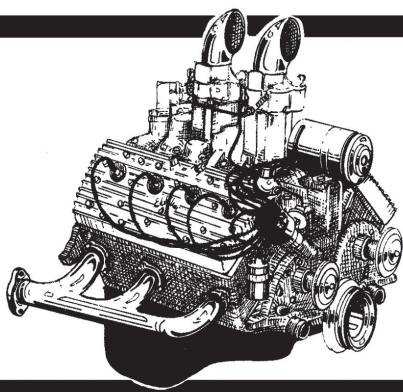

## ENGINE KITS FOR FLATHEAD FORD

DRESS UP YOUR VALUABLE  
HEAD WITH A SET OF  
STAINLESS FASTENERS!

### ENGINE KITS FOR 1939-48 FLATHEAD FORD V-8s

**ENGINE KITS-** Every engine kit includes component kits for the Distributor, Fuel Pump, Intake, Oil Pan, Timing Cover, and Water Pumps. Over 110 pieces and available in 5 different bolt styles!

Contains one of each component kit

		Price
BUTTON HEAD	# 6-0060	\$ 53.75
HEX HEAD (Stock Style)	6-0061	61.50
SOCKET HEAD	6-0062	64.00
SIX POINT - POLISHED - HIGH STRENGTH	6-0063	315.00
TWELVE POINT - POLISHED - HIGH STRENGTH	6-0064	331.50

\*\* NOTE SIX POINT & TWELVE POINT BOLTS ARE MADE IN USA \*\*

#### ACCESSORY KITS (NOT INCLUDED IN THE ENGINE KIT)

##### EXHAUST BOLT KITS

STOCK EXHAUST - HIGH STRENGTH		
STUDS & FLANGE NUTS	# 6-0054	\$ 128.50
-FOR HEADERS SEE 12 COUNT KITS - PAGES 6 & 7		

##### TRANSMISSION MOUNT KIT

SIX POINT - HIGH STRENGTH	6-0096	39.50
TWELVE POINT - HIGH STRENGTH	6-0097	43.00

##### 39-41 GENERATOR MOUNT KIT

HEX NUT, LOCK & FLAT WASHER	6-0098	5.50
-----------------------------	--------	------

##### 39-41 FAN PULLEY KIT

SIX POINT - HIGH STRENGTH	# 6-0099	\$ 19.00
TWELVE POINT - HIGH STRENGTH	6-0059	20.00

##### HEADBOLT KITS - INCLUDES WASHERS

- FOR STOCK HEADS ONLY		
SIX POINT - HIGH STRENGTH	6-0039	661.50
TWELVE POINT - HIGH STRENGTH	6-0042	665.50
- FOR ALUMINUM "OFFY" HEADS		
SIX POINT - HIGH STRENGTH	6-0014	827.50
TWELVE POINT - HIGH STRENGTH	6-0018	830.00

### ENGINE KITS FOR 1949-53 FLATHEAD FORD V-8s

**ENGINE KITS-** Every engine kit includes component kits for the Distributor, Fan Shaft Bracket, Fuel Pump, Intake, Oil Filter Housing, Oil Pan, Timing Cover, Water Necks, and Water Pumps. Over 115 pieces!

Contains one of each component kit

		Price
ORIGINAL STYLE- HAS INDENTED HEX BOLTS FOR THE OIL PAN, WATER NECKS, AND A STUD KIT FOR THE FUEL PUMP	# 6-0145	\$ 81.25
BUTTON HEAD	6-0100	73.50
HEX HEAD	6-0101	70.50
SOCKET HEAD	6-0102	82.00
SIX POINT - POLISHED - HIGH STRENGTH	6-0103	350.00
TWELVE POINT - POLISHED - HIGH STRENGTH	6-0104	370.50

\*\* NOTE INDENTED HEX, SIX POINT & TWELVE POINT BOLTS ARE MADE IN USA \*\*

#### ACCESSORY KITS (NOT INCLUDED IN THE ENGINE KIT)

##### EXHAUST BOLT KITS

-FOR HEADERS		
SIX POINT - HIGH STRENGTH	# 6-0149	\$ 62.50
TWELVE POINT - HIGH STRENGTH	6-0150	67.00
TOTAL-LOCS - SIX POINT	6-6972	99.00
-FOR STOCK EXHAUST		
HEX HEAD	6-0153	20.00

##### FRONT MOTOR MOUNT KITS

SIX POINT - HIGH STRENGTH	6-0147	39.50
TWELVE POINT - HIGH STRENGTH	6-0148	41.00

##### HEAD BOLT KITS- FOR STOCK HEADS ONLY -INCLUDES WASHERS-WE CAN DO PACKAGES FOR AFTER MARKET HEADS TOO!

SIX POINT - HIGH STRENGTH	# 6-0157	\$ 695.00
TWELVE POINT - HIGH STRENGTH	6-0055	706.50

##### BELLHOUSING KITS

HEX HEAD	6-0056	15.00
SOCKET HEAD	6-0057	24.00
SIX POINT - HIGH STRENGTH	6-0170	61.50
TWELVE POINT - HIGH STRENGTH	6-0171	62.50

**TOLL FREE ORDER LINE : 1-800-767-4781**

# ENGINE KITS FOR FORD Y-BLOCKS

**ENGINE KITS-** Every engine kit includes component kits for the Distributor, Fuel Pump, Intake, Oil Pan, Oil Pump Mount, Thermostat, Timing Chain Housing, Valley Cover, Valve Covers, and Water Pump. Over 115 pieces and available in 5 different bolt styles!

Contains one of every component kit

	FOR T-BIRDS:		FOR TRUCKS:		FOR ALL OTHER PASSENGER CARS	
BUTTON/SOCKET HEAD	# 6-9095	\$ 97.50	# 6-0479	\$ 93.75	# 6-0480	\$ 75.00
HEX HEAD	6-9096	85.00	6-0950	81.50	6-0779	72.50
SOCKET HEAD	6-9067	105.00	6-0951	104.00	6-0780	83.50
SIX POINT - POLISHED - HIGH STRENGTH	6-9098	290.50	6-0986	297.00	6-0781	293.50
TWELVE POINT - POLISHED - HIGH STRENGTH	6-9099	324.50	6-0987	339.00	6-0782	323.50

\*\* NOTE SIX POINT & TWELVE POINT BOLTS ARE MADE IN USA \*\*

## ACCESSORY KITS (NOT INCLUDED IN THE ENGINE KIT)

**CARB MOUNT KITS-** SEE PAGE 7

**RAMS HORN EXHAUST KITS**

**STOCK EXHAUST - ALL 1" BOLTS**

- (6) 1" & (8) 1 3/4" BOLTS WITH WASHERS

HEX HEAD	# 6-0488	\$ 18.50	HEX HEAD	# 6-0497	\$ 20.00
SIX POINT - HIGH STRENGTH	6-0489	70.50	SIX POINT - HIGH STRENGTH	6-0498	97.00
TWELVE POINT - HIGH STRENGTH	6-0490	78.00	TWELVE POINT - HIGH STRENGTH	6-0499	99.00

- FOR HEADERS SEE 14 COUNT KITS PAGES 6 & 7

# ENGINE KITS FOR FORD MODULAR 4.6 L

**ENGINE KITS-** Every engine kit includes component kits for the AC Compressor, Belt Pulleys, Cam Covers, Cam/Crank Sensors, Intake, Oil Pan, Oil Filter, Power Steering, Timing Cover, and Water Pump.

	Part #	Price:
<b>- KITS FOR SINGLE OVERHEAD CAM 16 VALVE ENGINES:</b>		
BUTTON HEAD	# 5-4700	\$ 146.00
SOCKET HEAD	5-4701	152.00
SIX POINT - POLISHED - HIGH STRENGTH	5-4702	687.00
TWELVE POINT - POLISHED - HIGH STRENGTH	5-4703	733.50
<b>- KITS FOR SINGLE OVERHEAD CAM 24 VALVE ENGINES 236 PIECES:</b>		
BUTTON HEAD	5-4750	151.75
SOCKET HEAD	5-4751	157.00
SIX POINT - POLISHED - HIGH STRENGTH	5-4752	865.50
TWELVE POINT - POLISHED - HIGH STRENGTH	5-4753	900.50
<b>- KITS FOR 1993-95 QUAD CAM ENGINES (WITH STEEL OIL PAN) 267PC:</b>		
BUTTON HEAD	5-4780	127.00
SOCKET HEAD	5-4781	128.75
SIX POINT - POLISHED - HIGH STRENGTH	5-4782	715.50
TWELVE POINT - POLISHED - HIGH STRENGTH	5-4783	798.50
<b>- KITS FOR 1996 &amp; UP QUAD CAM ENGINES (WITH STEEL OIL PAN) 267PC:</b>		
BUTTON HEAD	5-4600	120.00
SOCKET HEAD	5-4601	121.00
SIX POINT - POLISHED - HIGH STRENGTH	5-4602	716.00
TWELVE POINT - POLISHED - HIGH STRENGTH	5-4603	780.50
<b>- KITS FOR SUPERCHARGED QUAD CAM ENGINES (WITH CAST OIL PAN):</b>		
BUTTON HEAD	5-4664	132.00
SOCKET HEAD	5-4665	130.50
SIX POINT - POLISHED - HIGH STRENGTH	5-4666	822.50
TWELVE POINT - POLISHED - HIGH STRENGTH	5-4667	899.00

\*\* NOTE SIX POINT & TWELVE POINT BOLTS ARE MADE IN USA , STUD BOLTS ARE NOT INCLUDED IN KITS \*\*

## ACCESSORY KITS (NOT INCLUDED IN THE ENGINE KIT)

**BELL HOUSING KIT - WITH 60MM LONG BOLTS**

SIX POINT - HIGH STRENGTH	5-4788	69.50
TWELVE POINT - HIGH STRENGTH	5-4789	71.50

**HARMONIC BALANCER KIT**

SIX POINT - HIGH STRENGTH	5-4778	27.50
TWELVE POINT - HIGH STRENGTH	5-4779	28.50

**STARTER KIT**

SIX POINT - HIGH STRENGTH	5-4792	21.50
TWELVE POINT - HIGH STRENGTH	5-4793	22.50

**STUDS & STUD BOLTS**

6 X 48 STUD, NUT & WASHER 93-95	1-1919	7.50
6 X 73 STUD, NUT & WASHER 93-95	1-1921	7.75
8 X 50 STUD BOLT - TIMING COVER	1-1792	17.75
8 X 65 STUD BOLT - TIMING COVER	1-1793	18.00
8 X 78 STUD BOLT 93-95 LOWER INTAKE	1-1933	19.00
8 X 98 STUD BOLT 93-95 LOWER INTAKE	1-1935	20.00

\*FOR HEADERS SEE 16 COUNT KITS - PAGES 6 & 7



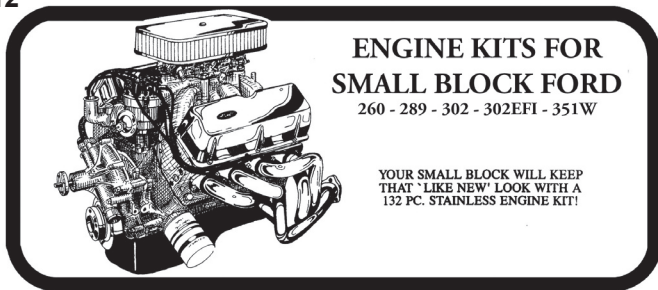

**ENGINE KITS FOR  
SMALL BLOCK FORD**

260 - 289 - 302 - 302EFI - 351W

YOUR SMALL BLOCK WILL KEEP  
THAT 'LIKE NEW' LOOK WITH A  
132 PC. STAINLESS ENGINE KIT!

**ENGINE KITS-** Every engine kit includes component kits for the Distributor, Fuel Pump, Intake, Oil Pan, Thermostat, Timing Chain Housing, Valve Covers, and Water Pump. Over 132 pieces and available in 5 to 6 different bolt styles!

\* NOTE INDENTED HEX, SIX POINT & 12 POINT BOLTS ARE MADE IN USA \*  
 FOR ENGINES WITH CAST VALVE COVERS      FOR ENGINES WITH SHEET METAL VALVE COVERS      PRICE:

**260 With Raised Water Pump (With Passenger Side Water Pump Inlet)**

BUTTON & SOCKET HEAD	# 6-9050	# 6-9056	\$ 68.75
HEX HEAD	6-9051	6-9057	67.50
HEX/INDENTED HEX (ORIGINAL STYLE)	6-9052	6-9058	115.00
SOCKET HEAD	6-9053	6-9059	65.25
SIX POINT - POLISHED - HIGH STRENGTH	6-9054	6-9060	332.50
TWELVE POINT - POLISHED - HIGH STRENGTH	6-9055	6-9061	366.00

**260, 289 & 302 (With Passenger Side Water Pump Inlet)**

BUTTON & SOCKET HEAD	# 6-0886	6-0881	68.00
HEX HEAD	6-0887	6-0925	66.75
HEX/INDENTED HEX (ORIGINAL STYLE)	6-0994	6-0995	112.00
SOCKET HEAD	6-0888	6-0926	74.50
SIX POINT - POLISHED - HIGH STRENGTH	6-0889	6-0927	336.00
TWELVE POINT - POLISHED - HIGH STRENGTH	6-0890	6-0929	367.50

**302 (With Driver Side Water Pump Inlet)**

BUTTON & SOCKET HEAD	6-0891	6-0502	67.00
HEX HEAD	6-0892	6-0500	66.75
HEX/INDENTED HEX (ORIGINAL STYLE)	6-0996	6-0997	120.00
SOCKET HEAD	6-0893	6-0501	74.50
SIX POINT - POLISHED - HIGH STRENGTH	6-0894	6-0598	342.50
TWELVE POINT - POLISHED - HIGH STRENGTH	6-0895	6-0599	380.00

**302 (5.0L) EFI (Passenger Car up thru 1993 ONLY)**

BUTTON & SOCKET HEAD	6-0896	6-0840	67.75
HEX HEAD	6-0897	6-0841	69.00
SOCKET HEAD	6-0898	6-0842	78.50
SIX POINT - POLISHED - HIGH STRENGTH	6-0935	6-0937	350.50
TWELVE POINT - POLISHED - HIGH STRENGTH	6-0936	6-0938	387.50

**302 (5.0L) EFI for 1994 & 1995 MUSTANG ONLY**

BUTTON & SOCKET HEAD	6-9012		68.75
HEX HEAD	6-9013		69.00
SOCKET HEAD	6-9019		77.00
SIX POINT - POLISHED - HIGH STRENGTH	6-9015		357.00
TWELVE POINT - POLISHED - HIGH STRENGTH	6-9016		392.00

**351W (With Driver Side Water Pump Inlet)**

BUTTON/SOCKET HEAD	6-0952	6-9023	76.00
HEX HEAD	6-0899	6-0829	73.00
HEX/INDENTED HEX (ORIGINAL STYLE)	6-0998	6-0999	111.00
SOCKET HEAD	6-0866	6-0835	79.00
SIX POINT - POLISHED - HIGH STRENGTH	6-0867	6-0836	356.00
TWELVE POINT - POLISHED - HIGH STRENGTH	6-0870	6-0837	411.00

**351W (With Passenger Side Water Pump Inlet)**

BUTTON/SOCKET HEAD	6-9025	6-9024	76.00
HEX HEAD	6-0786	6-0791	70.00
HEX/INDENTED HEX (ORIGINAL STYLE)	6-0787	6-0792	99.00
SOCKET HEAD	6-0788	6-0793	79.00
SIX POINT - POLISHED - HIGH STRENGTH	6-0789	6-0794	367.50
TWELVE POINT - POLISHED - HIGH STRENGTH	6-0790	6-0795	407.50

**STUD BOLTS FOR FORDS (NOT INCLUDED IN ENGINE KITS):**

**STUD BOLT KITS FOR FORD 5.0L WATER PUMPS IN: HIGH STRENGTH - 17-4 PH STAINLESS**

1985 MUSTANG WITH (2) SHORT, (2) MEDIUM, (1) LONG STUD BOLT, & FLANGE NUTS (ALSO USED ON SOME FORD TRUCKS & SUV APPLICATIONS)	6-9030	86.00
1986-1993 MUSTANG WITH (2) SHORT & (1) LONG STUD BOLT	6-9029	55.50
1994-1995 MUSTANG WITH (2) SHORT & (1) MEDIUM LENGTH STUD BOLT	6-9028	53.50

<b>TIMING COVER STUD BOLTS:</b> 2" 2-7036 14.95	<b>FOR GROUND STRAP:</b> (3/8-16 X 7/16-14)	2-7133 23.00
2 1/4" 2-7018 14.95		





## ACCESSORY KITS FOR SBF (NOT INCLUDED IN THE ENGINE KIT)

### ACCESSORY BRACKETS KIT - 1987-93

SIX POINT	# 6-0452	\$ 162.50
TWELVE POINT	6-0453	165.00

### BELLHOUSING KIT

#### -FOR AUTOMATICS WITH 2" BOLTS:

SIX POINT - HIGH STRENGTH	6-0861	61.00
TWELVE POINT - HIGH STRENGTH	6-0912	62.50

#### -FOR AUTOMATICS (AOD, ETC.) WITH 2 3/16" BOLTS:

SIX POINT - HIGH STRENGTH	5-4598	50.50
TWELVE POINT - HIGH STRENGTH	5-4599	57.00

#### -FOR MANUAL TRANSMISSION BELL HOUSINGS

##### WITH 1-1/2" & 2" BOLTS:

HEX HEAD	6-0939	13.75
SOCKET HEAD	6-0940	22.00
SIX POINT - HIGH STRENGTH	6-0941	57.50
TWELVE POINT - HIGH STRENGTH	6-0942	58.00

#### -FOR 64/66 WITH 1 1/2" LONG BOLTS

SIX POINT - HIGH STRENGTH	6-0826	53.50
TWELVE POINT - HIGH STRENGTH	6-0876	55.50

#### -FOR TREMEC 5 SPEED

SIX POINT - HIGH STRENGTH	6-0932	63.50
TWELVE POINT - HIGH STRENGTH	6-0933	65.00

### CARB MOUNT KITS -SEE PAGE 7

### COIL BRACKET KITS

BUTTON HEAD	6-0548	5.00
HEX HEAD	6-0540	4.75
INDENTED HEX HEAD	6-0753	7.50
SOCKET HEAD	6-0541	4.75
SIX POINT - HIGH STRENGTH	6-0913	12.00
TWELVE POINT - HIGH STRENGTH	6-0934	12.50

### CRANK PULLEY KITS

SIX POINT - HIGH STRENGTH	6-0576	21.50
TWELVE POINT - HIGH STRENGTH	6-0577	23.00

### FAN PULLEY KITS- SEE LISTING ON NEXT PAGE

### ENGINE MOUNT KITS

SIX POINT - HIGH STRENGTH	# 6-0833	\$ 25.50
TWELVE POINT - HIGH STRENGTH	6-0834	27.00

### EXHAUST BOLT KITS

#### -STOCK EXHAUST: (8) 1 1/4" & (8) 2" BOLTS

HEX HEAD- STOCK TYPE APPEARANCE BUT NOT AS STRONG AS STOCK	6-0877	26.75
SIX POINT - HIGH STRENGTH	6-0827	112.00
TWELVE POINT - HIGH STRENGTH	6-0828	119.50

#### -FOR HEADERS SEE 16 COUNT KIT- PAGES 6 & 7

### HARMONIC BALANCER KIT

SIX POINT - HIGH STRENGTH	6-0725	52.50
---------------------------	--------	-------

### OUTSIDE HEADBOLT KITS (Except 351)

SIX POINT - HIGH STRENGTH	6-0796	96.50
TWELVE POINT - HIGH STRENGTH	6-9017	120.00

#### - FOR 351W WITH 3" LONG OUTER BOLTS:

SIX POINT - HIGH STRENGTH	6-0454	126.50
TWELVE POINT - HIGH STRENGTH	6-0455	128.50

### HEAD BOLT WASHERS FOR ALUMINUM HEADS

OUTSIDE SET (10) FOR: 260/289/302	6-0456	26.50
OUTSIDE SET FOR 351W:	6-9026	58.50

### 7/16-14 HEADBOLT WITH 3/8-16 X 1 1/2" STUD

2-7052	25.00
--------	-------

### STARTER KITS

BUTTON HEAD	6-0580	4.50
HEX HEAD	6-0533	4.75
SOCKET HEAD	6-0534	5.00
SIX POINT - HIGH STRENGTH	6-0800	13.00
TWELVE POINT - HIGH STRENGTH	6-0801	14.50

### TRANSMISSION KITS -SEE PAGE 30

## KITS FOR 351C/351M/400M FORD ENGINES

**ENGINE KITS-** Every engine kit includes component kits for the Distributor, Fuel Pump, Intake, Oil Pan, Thermostat, Timing Chain Housing, Valve Covers, and Water Pump. Over 115 pieces and available in 6 different bolt styles! \*\* NOTE INDENTED HEX, SIX POINT & TWELVE POINT BOLTS ARE MADE IN USA \*\*

#### FOR ENGINES WITH:

#### CAST VALVE COVERS

#### SHEET METAL VALVE COVERS

#### Price:

### 351C - FOR ENGINES WITH (4) 1 3/4" & (4) 2 1/4" LONG INTAKE BOLTS PLUS THE 5/16" BOLTS

BUTTON & SOCKET HEAD	# 6-0673	# 6-0678	\$ 60.50
HEX HEAD	6-0674	6-0679	64.50
HEX/INDENTED HEX HEAD (ORIGINAL STYLE)	6-0770	6-0771	101.00
SOCKET HEAD	6-0675	6-0680	67.75
SIX POINT - POLISHED - HIGH STRENGTH	6-0676	6-0681	356.00
TWELVE POINT - POLISHED - HIGH STRENGTH	6-0677	6-0682	383.00

### 351C/M & 400M - FOR ENGINES WITH (8) 2 1/4" LONG INTAKE BOLTS PLUS THE 5/16" BOLTS

BUTTON & SOCKET HEAD	# 6-0683	# 6-0550	\$ 57.50
HEX HEAD	6-0684	6-0551	61.50
HEX/INDENTED HEX HEAD (ORIGINAL STYLE)	6-0772	6-0773	101.00
SOCKET HEAD	6-0685	6-0552	64.50
SIX POINT - POLISHED - HIGH STRENGTH	6-0686	6-0819	358.50
TWELVE POINT - POLISHED - HIGH STRENGTH	6-0687	6-0820	387.50

## ACCESSORY KITS (NOT INCLUDED IN THE ENGINE KIT)

### BELLHOUSING KIT - WITH 1 1/2" BOLTS

SIX POINT - HIGH STRENGTH	# 6-0826	\$ 53.50
TWELVE POINT - HIGH STRENGTH	6-0876	55.50

### CRANK PULLEY KITS

SIX POINT - HIGH STRENGTH	6-0576	21.50
TWELVE POINT - HIGH STRENGTH	6-0577	23.00

### EXHAUST BOLT KITS - SEE 16 COUNT KITS ON PAGES 6 & 7

### ENGINE MOUNT KITS

SIX POINT - HIGH STRENGTH	#6-0798	\$37.00
TWELVE POINT - HIGH STRENGTH	6-0799	38.00

### STARTER KITS

BUTTON HEAD	6-0570	4.50
HEX HEAD	6-0571	4.75
SOCKET HEAD	6-0582	5.00
SIX POINT - HIGH STRENGTH	6-0817	12.50
TWELVE POINT - HIGH STRENGTH	6-0818	13.50

# 14 KITS FOR FE (352-390-406-410-427-428) FORD ENGINES

**ENGINE KITS-** Every engine kit includes component kits for the Distributor, Fuel Pump, Intake, Oil Filter, Oil Pan, Thermostat Housing, Timing Chain Housing, Valve Covers, and Water Pump. Over 115 pieces and available in 6 different bolt styles! \*\* NOTE INDENTED HEX, SIX POINT & TWELVE POINT BOLTS ARE MADE IN USA \*\*

	FOR ENGINES WITH CAST VALVE COVERS	FOR ENGINES WITH SHEET METAL VALVE COVERS	PRICE:
BUTTON HEAD	# 6-0690	# 6-0600	\$ 56.75
HEX HEAD	6-0691	6-0601	63.50
HEX & INDENTED HEX HEAD (ORIGINAL STYLE) - HAS INDENTED HEX BOLTS FOR FUEL PUMP, OIL FILTER, OIL PAN, TIMING COVER, THERMOSTAT & VALVE COVERS	6-0699	6-0663	88.00
SOCKET HEAD	6-0692	6-0602	64.50
SIX POINT - POLISHED - HIGH STRENGTH	6-0693	6-0632	327.00
TWELVE POINT - POLISHED - HIGH STRENGTH	6-0694	6-0633	346.00

## ACCESSORY KITS (NOT INCLUDED IN THE ENGINE KIT)

### BELLHOUSING KIT

- FOR AUTOMATIC WITH 2 1/4" BOLTS:

SIX POINT - HIGH STRENGTH	# 6-0861	\$ 61.00
TWELVE POINT - HIGH STRENGTH	6-0625	56.50

- FOR C6 AUTOMATICS & MANUALS: WITH 1 1/2" BOLTS

SIX POINT - HIGH STRENGTH	6-0826	53.50
TWELVE POINT - HIGH STRENGTH	6-0876	55.50

**CARB MOUNT KITS** - SEE PAGE 7

### CRANK PULLEY

SIX POINT - HIGH STRENGTH	6-0631	16.00
TWELVE POINT - HIGH STRENGTH	6-0627	17.00

### ENGINE MOUNT KITS

SIX POINT - HIGH STRENGTH	6-0667	75.00
TWELVE POINT - HIGH STRENGTH	6-0664	78.00

### PLUG WIRE HOLDER STUD BOLTS:

1/4-20 X 9/16 - 2-9/16 OVERALL LENGTH	2-7002	\$ 14.00
1/4-20 X 13/16 - 2-1/4 OVERALL LENGTH	2-7003	14.50
1/4-20 X 1 - 3" OVERALL LENGTH	2-7004	15.50

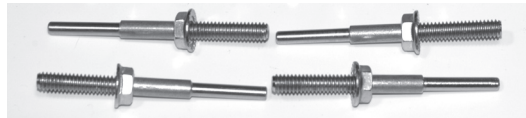

### EXHAUST BOLT KITS

- HEADERS: SEE 16 COUNT KITS ON PAGES 6 & 7

- STOCK EXHAUST: 1 1/2" LONG BOLTS:

HEX HEAD	# 6-0878	\$ 19.00
SIX POINT - HIGH STRENGTH	6-0812	117.50
TWELVE POINT - HIGH STRENGTH	6-0813	123.50

### HARMONIC BALANCER KIT - 2" BOLT

SIX POINT - HIGH STRENGTH	6-0630	57.00
---------------------------	--------	-------

### STARTER KITS

BUTTON HEAD	6-0653	5.00
HEX HEAD	6-0623	5.25
SOCKET HEAD	6-0624	5.50
SIX POINT - HIGH STRENGTH	6-0655	18.50
TWELVE POINT - HIGH STRENGTH	6-0656	19.50

# KITS FOR 429-460 FORD ENGINES

**ENGINE KITS-** Every engine kit includes component kits for the Distributor, Fuel Pump, Intake, Oil Pan, Thermostat, Front Cover, Valve Covers, and Water Pump. Over 115 pieces and available in 6 different bolt styles! \*\* NOTE INDENTED HEX, SIX POINT & TWELVE POINT BOLTS ARE MADE IN USA \*\*

	FOR ENGINES WITH CAST VALVE COVERS	FOR ENGINES WITH SHEET METAL VALVE COVERS	PRICE
BUTTON HEAD	# 6-6320	# 6-6325	\$ 71.50
HEX HEAD	6-6321	6-6326	73.75
INDENTED HEX/HEX HEAD (ORIGINAL STYLE)	6-6305	6-6306	145.00
SOCKET HEAD	6-6322	6-6327	94.00
SIX POINT - POLISHED - HIGH STRENGTH	6-6323	6-6328	424.00
TWELVE POINT - POLISHED - HIGH STRENGTH	6-6324	6-6329	460.00

## ACCESSORY KITS (NOT INCLUDED IN THE ENGINE KITS)

### BELLHOUSING KITS - WITH 1 1/2" BOLTS

SIX POINT - HIGH STRENGTH	# 6-0826	\$ 53.50
TWELVE POINT - HIGH STRENGTH	6-0876	55.50

**CARB MOUNT KITS** - SEE PAGE 7

### CRANK PULLEY KITS

SIX POINT - HIGH STRENGTH	6-0714	20.50
TWELVE POINT - HIGH STRENGTH	6-0715	22.50

### FAN PULLEY KITS- 3/4" LONG BOLTS

-STEEL PULLEYS WITHOUT A SPACER:

SIX POINT - HIGH STRENGTH	6-5609	19.50
TWELVE POINT - HIGH STRENGTH	6-5607	20.50

-ALUMINUM PULLEYS: WITH COUNTERSUNK HOLES  
AND NO FAN BLADE

FLAT SOCKET	6-5608	5.25
-------------	--------	------

### EXHAUST BOLT KITS

- SEE 16 COUNT BOLT KITS ON PAGES 6 & 7

### ENGINE MOUNT KITS

SIX POINT - HIGH STRENGTH	# 6-0667	\$ 75.00
TWELVE POINT - HIGH STRENGTH	6-0664	78.00

### STARTER KITS

BUTTON HEAD	6-0745	4.50
HEX HEAD	6-0750	4.75
SOCKET HEAD	6-0751	5.00
SIX POINT - HIGH STRENGTH	6-0746	12.50
TWELVE POINT - HIGH STRENGTH	6-0747	14.00

### HARMONIC BALANCER KIT - 1-3/4" BOLT

SIX POINT - HIGH STRENGTH	6-6319	58.50
---------------------------	--------	-------

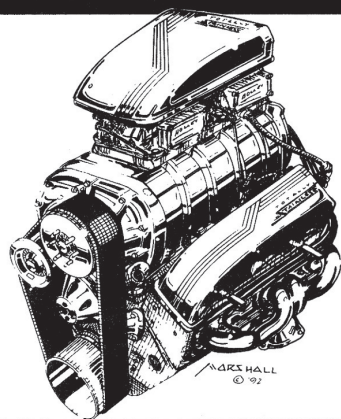

## ENGINE KITS FOR GENERAL MOTORS

BUICK - CADILLAC - CHEVROLET  
OLDSMOBILE - PONTIAC

### KITS FOR BUICK 231 V6 ENGINES

**ENGINE KITS-** Every engine kit includes component kits for the Distributor, Front Cover/Water Pump, Fuel Pump (Non-Turbo), Intake, Oil Pan, Thermostat Housing, Timing Cover, and Valve Covers. Turbo Kits also Include kits for the Coil Pack/Bracket, Fuel Rail, Throttle Body & Plenum. Over 115 pieces and available in 5 to 6 different bolt styles!

	FOR ENGINES WITH CAST VALVE COVERS	FOR ENGINES WITH SHEET METAL VALVE COVERS	PRICE
<b>CARBURATED ENGINES</b>			
BUTTON & SOCKET HEAD	# 6-5927	# 6-5900	\$ 67.00
HEX HEAD	6-5928	6-5901	60.50
HEX/INDENTED HEX HEAD (ORIGINAL STYLE)	6-5992	6-5993	100.00
SOCKET HEAD	6-5929	6-5902	75.75
SIX POINT - POLISHED - HIGH STRENGTH	6-5937	6-5938	293.50
TWELVE POINT - POLISHED - HIGH STRENGTH	6-5940	6-5941	297.50

	FOR ENGINES WITH CAST VALVE COVERS	PRICE	FOR ENGINES WITH VALVE COVER WITH STUDS	PRICE
<b>TURBO CHARGED ENGINES</b>				
BUTTON & SOCKET HEAD	6-5987	95.75	6-5774	104.50
HEX HEAD	6-5988	88.00	6-5775	84.50
SOCKET HEAD	6-5989	92.50	6-5776	103.00
SIX POINT - POLISHED - HIGH STRENGTH	6-5990	390.00	6-5777	369.50
TWELVE POINT - POLISHED - HIGH STRENGTH	6-5867	499.00	6-5778	457.50

\*\* NOTE INDENTED HEX, SIX POINT & TWELVE POINT BOLTS ARE MADE IN USA \*\*

### ACCESSORY KITS (NOT INCLUDED IN THE ENGINE KITS)

**BELLHOUSING KITS** - SEE PAGE 29

**CARB MOUNT KITS** -SEE PAGE 7

#### EXHAUST BOLT KITS

-HEADERS SEE 12 COUNT KITS- PAGES 6 & 7

-STOCK EXHAUST

SIX POINT - HIGH STRENGTH	# 6-5905	\$ 96.50
TWELVE POINT - HIGH STRENGTH	6-5906	99.00
-TURBO V6		
SIX POINT - HIGH STRENGTH	6-5920	73.00
TWELVE POINT - HIGH STRENGTH	6-5862	77.00

#### ENGINE MOUNTS KIT

SIX POINT	6-5798	29.00
TWELVE POINT	6-5799	31.00

#### FAN PULLEY KIT- 3/4" LONG BOLTS

- FOR STEEL PULLEYS WITHOUT A SPACER:

SIX POINT - HIGH STRENGTH	# 6-5609	\$ 19.50
TWELVE POINT - HIGH STRENGTH	6-5607	20.50

- FOR ALUMINUM PULLEYS: WITH COUNTERSUNK HOLES

FLAT SOCKET	6-5608	5.25
-------------	--------	------

#### CRANK PULLEY KIT

SIX POINT - HIGH STRENGTH	6-5796	26.00
TWELVE POINT - HIGH STRENGTH	6-5797	28.00

#### ACCESSORY BELT DRIVE KIT FOR TURBO V6

1986:

SIX POINT & SERRATED FLANGE NUTS	6-5772	170.50
TWELVE POINT & SERRATED FLANGE NUTS	6-5773	177.00

1987:

SIX POINT & SERRATED FLANGE NUTS	6-5788	145.50
TWELVE POINT & SERRATED FLANGE NUTS	6-5789	170.00

## ENGINE KIT FOR BUICK STRAIGHT 8

- INCLUDES STUDS & HEAVY DUTY WASHERS FOR INTAKE/EXHAUST

BUTTON HEAD	6-2550	177.00
HEX HEAD	6-2551	170.25
SOCKET HEAD	6-2553	185.00
SIX POINT - POLISHED	6-2554	399.00
TWELVE POINT - POLISHED	6-2555	425.00

# 16 KITS FOR 215 BUICK/OLDS/ROVER ENGINES

**ENGINE KITS-** Every engine kit includes component kits for the Distributor, Fuel Pump, Intake, Oil Filter, Oil Pan, Thermostat Housing, Timing Cover, Valve Covers, and Water Pump. Over 115 pieces and available in 6 different bolt styles! \*\* NOTE INDENTED HEX, SIX POINT & TWELVE POINT BOLTS ARE MADE IN USA \*\*

	FOR ENGINES WITH CAST VALVE COVERS	FOR ENGINES WITH SHEET METAL VALVE COVERS	PRICE:
BUTTON/SOCKET HEAD	# 6-4820	# 6-4825	\$ 81.50
HEX HEAD	6-4800	6-4826	84.50
HEX/INDENTED HEX (ORIGINAL STYLE)	6-4821	6-4827	129.00
SOCKET HEAD	6-4822	6-4828	88.50
SIX POINT - POLISHED - HIGH STRENGTH	6-4823	6-4829	360.50
TWELVE POINT - POLISHED - HIGH STRENGTH	6-4824	6-4830	389.00

## ACCESSORY KITS (NOT INCLUDED IN THE ENGINE KITS)

**BELLHOUSING KITS-** SEE PAGE 29 -NOTE:  
USE THE 1 1/2" LONG KIT FOR AUTOMATICS

**FOR 5 SPEED ROVER:**

SIX POINT - HIGH STRENGTH # 6-6400 \$ 70.50

### ENGINE MOUNT KITS

SIX POINT - HIGH STRENGTH 6-4842 27.50  
TWELVE POINT - HIGH STRENGTH 6-4848 28.50

### FAN PULLEY KITS- 3/4" LONG BOLTS

**-STEEL PULLEYS WITHOUT A SPACER:**

SIX POINT - HIGH STRENGTH 6-5609 19.50  
TWELVE POINT - HIGH STRENGTH 6-5607 20.50

**-ALUMINUM PULLEYS: WITH COUNTERSUNK HOLES  
AND NO FAN BLADE**

FLAT SOCKET 6-5608 5.25

**CARB MOUNT KITS - SEE PAGE 7**

### HARMONIC BALANCER KIT

SIX POINT - HIGH STRENGTH # 6-4889 \$ 52.50

### EXHAUST BOLT KITS

-HEADERS: SEE 16 COUNT BOLT KITS PAGES 6 & 7

-STOCK EXHAUST:

HEX HEAD 6-4810 16.00  
SIX POINT - HIGH STRENGTH 6-4831 77.00  
TWELVE POINT - HIGH STRENGTH 6-4837 84.00

### STARTER KITS

HEX HEAD 6-4809 5.00  
SOCKET HEAD 6-4853 5.25  
SIX POINT - HIGH STRENGTH 6-4858 13.50  
TWELVE POINT - HIGH STRENGTH 6-4862 14.50

# KITS FOR BUICK NAILHEAD ENGINES

**ENGINE KITS-** Every engine kit includes component kits for the Distributor, Fuel Pump, Intake Manifold, Oil Filter, Oil Pan, Thermostat Housing, Timing Cover, Valley Cover, Valve Covers, and Water Pump. Over 115 pieces and available in 6 different bolt styles!

\* NOTE INDENTED HEX, SIX POINT &  
12 POINT BOLTS ARE MADE IN USA \*

	FOR ENGINES WITH CAST VALVE COVERS	FOR ENGINES WITH SHEET METAL VALVE COVERS	PRICE:
BUTTON/SOCKET HEAD	# 6-4900	# 6-4907	\$ 70.00
HEX HEAD	6-4901	6-4908	84.00
HEX/INDENTED HEX (ORIGINAL STYLE)	6-4902	6-4909	122.00
SOCKET HEAD	6-4903	6-4910	90.00
SIX POINT - POLISHED - HIGH STRENGTH	6-4904	6-4911	363.00
TWELVE POINT - POLISHED - HIGH STRENGTH	6-4905	6-4912	391.50

## ACCESSORY KITS (NOT INCLUDED IN THE ENGINE KITS)

### BELLHOUSING KITS

SIX POINT - HIGH STRENGTH # 6-4976 \$ 56.50  
TWELVE POINT - HIGH STRENGTH 6-4977 59.50

### CAST PLUG WIRE COVERS

BUTTON HEAD 6-4963 7.00  
HEX HEAD 6-4964 7.25  
SOCKET HEAD 6-4965 7.50  
SIX POINT - HIGH STRENGTH 6-4966 35.00  
TWELVE POINT - HIGH STRENGTH 6-4967 36.50

### CRANK PULLEY KITS

SIX POINT - HIGH STRENGTH 6-4968 28.50  
TWELVE POINT - HIGH STRENGTH 6-4969 29.50

### ENGINE MOUNT KITS

SIX POINT - HIGH STRENGTH 6-4970 36.00  
TWELVE POINT - HIGH STRENGTH 6-4971 38.50

### EXHAUST STUD - SPECIAL STEPPED STUDS:

7/16-14 X 1/2-13 X 1 7/8" LONG  
SET OF 4 STUDS - HIGH STRENGTH 6-4990 79.00

**CARB MOUNT KITS-** SEE PAGE 7

### EXHAUST BOLT KITS

-HEADERS: SEE 16 COUNT BOLT KITS PAGES 6 & 7

-STOCK EXHAUST:

HEX HEAD 6-4973 \$ 22.00  
SOCKET HEAD 6-4975 24.00  
SIX POINT - HIGH STRENGTH 6-4972 90.50  
TWELVE POINT - HIGH STRENGTH 6-4974 95.00

### OUTSIDE HEAD BOLT KITS

SIX POINT - HIGH STRENGTH 6-4978 212.50  
TWELVE POINT - HIGH STRENGTH 6-4988 241.50  
**HEADBOLT WITH 7/16-20 X 1 3/8 STUD** 2-7057 27.50

### STARTER KITS

HEX HEAD 6-4984 6.00  
SOCKET HEAD 6-4985 6.50  
SIX POINT - HIGH STRENGTH 6-4986 14.50  
TWELVE POINT - HIGH STRENGTH 6-4987 16.00

### WATER CROSSOVER STUD BOLT

3/8-16 X2 UNDER HEAD, 3/4" STUD ON TOP 2-7022 17.00



# KITS FOR 350 - 400 - 430 - 455 BUICK V8 ENGINES <sup>17</sup>

**ENGINE KITS-** Every engine kit includes component kits for the Distributor, Fuel Pump, Intake, Oil Pan, Thermostat, Timing Cover, Valve Covers, and Water Pump. Available in 6 different bolt styles!

\* NOTE INDENTED HEX, SIX POINT & 12 POINT BOLTS ARE MADE IN USA \*

FOR ENGINES WITH CAST VALVE COVERS

FOR ENGINES WITH SHEET METAL VALVE COVERS

PRICE:

## 350

BUTTON & SOCKET HEAD	# 6-5896	# 6-5800	\$ 65.75
HEX HEAD	6-5897	6-5801	66.75
HEX/INDENTED HEX HEAD (ORIGINAL STYLE)	6-5974	6-5975	97.00
SOCKET HEAD	6-5898	6-5802	71.00
SIX POINT - POLISHED - HIGH STRENGTH	6-5944	6-5945	325.00
TWELVE POINT - POLISHED - HIGH STRENGTH	6-5946	6-5947	350.00

## 400 - 430

BUTTON & SOCKET HEAD	6-5930	6-5886	65.00
HEX HEAD	6-5931	6-5887	66.00
HEX/INDENTED HEX HEAD (ORIGINAL STYLE)	6-5889	6-5969	98.00
SOCKET HEAD	6-5932	6-5888	71.50
SIX POINT - POLISHED - HIGH STRENGTH	6-5950	6-5951	332.50
TWELVE POINT - POLISHED - HIGH STRENGTH	6-5952	6-5953	357.50

## 455

BUTTON & SOCKET HEAD	6-5933	6-5850	76.00
HEX HEAD	6-5934	6-5851	65.00
HEX/INDENTED HEX HEAD (ORIGINAL STYLE)	6-5890	6-5967	88.00
SOCKET HEAD	6-5935	6-5852	82.50
SIX POINT - POLISHED - HIGH STRENGTH	6-5954	6-5955	355.50
TWELVE POINT - POLISHED - HIGH STRENGTH	6-5956	6-5957	373.00

## ACCESSORY KITS (NOT INCLUDED IN THE ENGINE KIT)

**BELLHOUSING KITS-** SEE PAGE 29

**CARB MOUNT KITS-** SEE PAGE 7

### CRANK PULLEY KITS

SIX POINT - HIGH STRENGTH	# 6-5884	\$ 26.00
TWELVE POINT - HIGH STRENGTH	6-5885	27.50

### ENGINE MOUNT KITS

SIX POINT - HIGH STRENGTH	6-5841	26.00
TWELVE POINT - HIGH STRENGTH	6-5842	27.50

### FAN PULLEY KITS- 3/4" LONG BOLTS

**-STEEL PULLEYS WITHOUT A SPACER:**

SIX POINT - HIGH STRENGTH	6-5609	19.50
TWELVE POINT - HIGH STRENGTH	6-5607	20.50

**-ALUMINUM PULLEYS: WITH COUNTERSUNK HOLES AND NO FAN BLADE**

FLAT SOCKET	6-5608	5.25
-------------	--------	------

### HARMONIC BALANCER KIT

- FOR 455

SIX POINT - HIGH STRENGTH	6-9695	72.00
---------------------------	--------	-------

### EXHAUST BOLT KITS

-FOR HEADERS SEE 14 COUNT KITS ON PAGES 6 & 7

-FOR 350 GS STOCK EXHAUST:

HEX HEAD	# 6-5960	\$ 28.00
----------	----------	----------

-FOR 400-455 GS STOCK EXHAUST:

HEX HEAD	6-5899	25.00
SIX POINT - HIGH STRENGTH	6-5904	103.00

### HEAD BOLT KITS FOR 455-V8

**COMPLETE SET (OUTSIDE & INSIDE)**

SIX POINT - HIGH STRENGTH	6-9698	293.00
TWELVE POINT - HIGH STRENGTH	6-9699	295.00

### OUTSIDE BOLTS ONLY

SIX POINT - HIGH STRENGTH	6-9696	137.50
TWELVE POINT - HIGH STRENGTH	6-9697	139.00

### HEAD BOLT WASHERS FOR ALUMINUM HEADS

OUTSIDE SET (10) 17-4 PH WASHERS	6-9026	58.50
----------------------------------	--------	-------

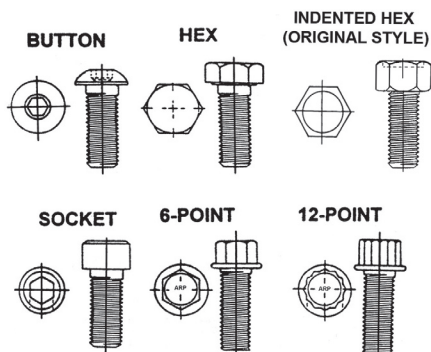

How about a 401 nailhead installed mid-ship in a 2 ton 1937 flatbed? It was 1973 - look how skinny we were!



# KITS FOR CADILLAC ENGINES

**331 - 365 - 390 - 425 - 429 - 472 - 500**

**ENGINE KITS-** Every engine kit includes component kits for the Distributor, Fuel Pump, Intake, Oil Filter Housing, Oil Pan, Thermostat Housing, Timing Cover, Valve Covers, and Water Pump. The 331/365/390 kits also include component kits for the Coil Bracket, Valley Cover and Ground Straps.

<b>331/365/EARLY 390 (UP THRU 1962)</b>	<b>Part #</b>	<b>Price</b>
HEX & INDENTED HEX -ORIGINAL STYLE - INCLUDES STUDS AND SPECIAL 1 3/8 OD INTAKE WASHERS - 160 PC	6-6700	\$ 176.00
** WE CAN MAKE KITS FOR THESE IN OTHER BOLT STYLES - JUST GIVE US A CALL **		
<b>LATE 390 (1963 &amp; UP) / 429</b>		
BUTTON & SOCKET HEAD	6-6750	105.00
HEX & INDENTED HEX - ORIGINAL STYLE WITH INTAKE STUDS	6-6751	220.00
<b>425/472/500</b>		
BUTTON HEAD	6-5700	62.00
HEX HEAD	6-5701	67.00
INDENTED HEX -ORIGINAL STYLE	6-5755	149.00
SOCKET HEAD	6-5702	71.00
SIX POINT - POLISHED - HIGH STRENGTH	6-5703	359.50
TWELVE POINT - POLISHED - HIGH STRENGTH	6-5704	385.50
** NOTE INDENTED HEX, SIX POINT & TWELVE POINT BOLTS ARE MADE IN USA **		

## ACCESSORY KITS (NOT INCLUDED IN THE ENGINE KIT)

**BELLHOUSING KITS** (1 1/2" LONG BOLTS)  
 SIX POINT - HIGH STRENGTH # 6-5180 \$ 47.00  
 TWELVE POINT - HIGH STRENGTH 6-5181 49.00

**CARB MOUNT KITS** - SEE PAGE 7

### CRANK PULLEY KITS

**- 331/365/EARLY 390:**  
 SIX POINT - HIGH STRENGTH 6-6715 26.00  
**- 425/472/500 (STOCK 3/4" LONG BOLTS):**  
 SIX POINT - HIGH STRENGTH 6-5750 17.50  
 TWELVE POINT - HIGH STRENGTH 6-5751 21.00  
**- 425/472/500 WITH BILLET PULLEY (1" LONG BOLTS):**  
 SIX POINT - HIGH STRENGTH 6-5790 21.00

### FAN PULLEY KITS -3/4" LONG BOLTS

**-STEEL PULLEY WITHOUT A SPACER:**  
 SIX POINT - HIGH STRENGTH 6-5609 19.50  
 TWELVE POINT - HIGH STRENGTH 6-5607 20.50  
**- ALUMINUM PULLEYS: WITH COUNTERSUNK HOLES AND NO FAN BLADE**  
 FLAT SOCKET 6-5608 5.25

### HARMONIC BALANCER KIT

**- 331/365/EARLY 390**  
 SIX POINT # 6-6721 \$ 26.50

### STARTER KITS

**-331/365/EARLY 390:**  
 HEX HEAD 6-6713 7.75  
**-425/472/500 - KNURLED**  
 SIX POINT - HIGH STRENGTH 6-5718 34.00  
 TWELVE POINT - HIGH STRENGTH 6-5719 35.50

### EXHAUST KITS

**331/365:**  
 HEX HEAD - STOCK 6-6719 31.50  
**390/429:**  
 HEX HEAD - STOCK 6-6770 34.00  
 SIX POINT - FOR HEADERS 6-6769 70.00  
**425/472/500**  
 HEX HEAD - STOCK 6-5117 24.75  
 SIX POINT - HIGH STRENGTH 6-5768 130.50  
 TWELVE POINT - HIGH STRENGTH 6-5597 136.50  
**- FOR 331-365, & 425-500 HEADERS SEE 16 COUNT KITS ON PAGES 6 & 7**

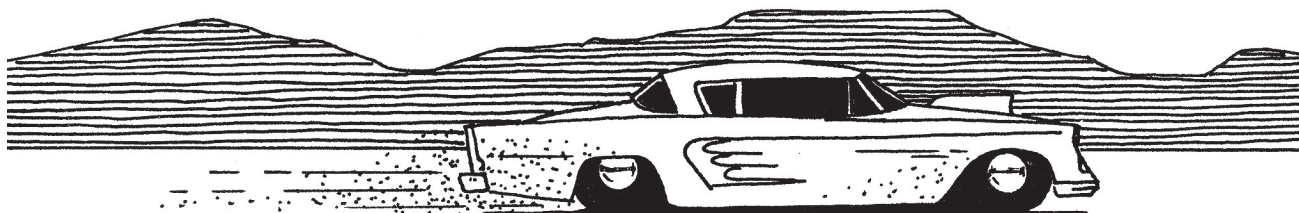

**TOLL FREE ORDER LINE : 1-800-767-4781**

# KITS FOR CHEVY STRAIGHT SIX ENGINES

194 - 216 - 230 - 235 - 250 - 261 - 292

**ENGINE KITS**- Every engine kit includes component kits for the Distributor, Fuel Pump, Intake/Exhaust Manifold, Oil Pan, Side Cover (Push Rod CVR), Thermostat Housing, Timing Cover, Valve Cover, and Water Pump. Available in 6 different bolt styles!

FOR ENGINES WITH: Contains one of each component kit	CAST VALVE COVER	SHEET METAL VALVE COVER	PRICE:
<b>216</b>			
BUTTON/SOCKET HEAD		# 6-7610	\$ 57.00
HEX HEAD		6-7611	64.50
SLOTTED & HEX CAP - ORIGINAL STYLE		6-7612	67.00
SOCKET HEAD		6-7613	70.75
SIX POINT - POLISHED - HIGH STRENGTH		6-7652	297.50
TWELVE POINT - POLISHED - HIGH STRENGTH		6-7614	321.50
<b>235 (1953-54)</b>			
BUTTON/SOCKET HEAD	# 6-7653	6-7659	63.00
HEX HEAD	6-7654	6-7660	68.00
INDENTED HEX -ORIGINAL STYLE	6-7655	6-7661	102.00
SOCKET HEAD	6-7656	6-7662	76.00
SIX POINT - POLISHED - HIGH STRENGTH	6-7657	6-7663	330.00
TWELVE POINT - POLISHED - HIGH STRENGTH	6-7658	6-7664	342.50
<b>235/261 (1955-62)</b>			
BUTTON HEAD	6-7500	6-7594	63.00
HEX HEAD	6-7501	6-7595	68.00
HEX/INDENTED HEX -ORIGINAL STYLE	6-7503	6-7597	99.00
SOCKET HEAD	6-7502	6-7596	76.00
SIX POINT - POLISHED - HIGH STRENGTH	6-7504	6-7598	330.00
TWELVE POINT - POLISHED - HIGH STRENGTH	6-7505	6-7599	342.50
<b>194/230/250/292</b>			
BUTTON HEAD	6-7506	6-7600	67.00
HEX HEAD	6-7507	6-7601	70.50
HEX/INDENTED HEX -ORIGINAL STYLE	6-7509	6-7603	118.00
SOCKET HEAD	6-7508	6-7602	75.00
SIX POINT - POLISHED - HIGH STRENGTH	6-7510	6-7604	371.00
TWELVE POINT - POLISHED - HIGH STRENGTH	6-7511	6-7605	356.00

\*\* NOTE INDENTED HEX, SIX POINT & TWELVE POINT BOLTS ARE MADE IN USA \*\*

## ACCESSORY KITS (NOT INCLUDED IN THE ENGINE KIT)

### FRONT ENGINE MOUNT KITS

-194/230/250/292			
SIX POINT - HIGH STRENGTH	# 6-7586	\$ 29.00	
TWELVE POINT - HIGH STRENGTH	6-7587	31.50	
- 216/235 (1954 & EARLIER)			
CARRIAGE HEAD	6-7672	74.00	
- 235/261 (1955-62)			
SIX POINT - HIGH STRENGTH	6-7584	22.50	
TWELVE POINT - HIGH STRENGTH	6-7585	25.50	

### GENERATOR MOUNT KITS - 235 & 261 ONLY

BUTTON HEAD	6-7681	5.25	
HEX HEAD	6-7590	5.50	
SOCKET HEAD	6-7591	5.50	
SIX POINT - HIGH STRENGTH	6-7592	13.50	
TWELVE POINT - HIGH STRENGTH	6-7593	15.50	

### HEAD BOLT KIT - OUTSIDE BOLTS ONLY

235-261 (1955-62) - HIGH STRENGTH BOLTS & WASHERS:		
SIX POINT - POLISHED	# 6-7609	\$ 163.50

### INTAKE/EXHAUST FOR HEADERS

-194/230/250/292		
SIX POINT - HIGH STRENGTH	6-7670	45.00
TWELVE POINT - HIGH STRENGTH	6-7671	49.00

### STARTER KITS - 216/235/261 ONLY

HEX HEAD	6-7588	5.75
SOCKET HEAD	6-7589	6.00
SIX POINT - HIGH STRENGTH	6-7682	14.50
TWELVE POINT - HIGH STRENGTH	6-7683	16.50

# KITS FOR CHEVY 2.8 / 3.4 LITER V6 ENGINES

**ENGINE KITS**- Every engine kit includes component kits for the Distributor, Fuel Pump, Intake, Oil Pan, Thermostat, Timing Cover, Valve Covers, and Water Pump.

Contains one of each component kit		
BUTTON HEAD	# 5-1300	\$ 54.75
HEX HEAD	5-1301	50.50
SOCKET HEAD	5-1302	55.75
SIX POINT - POLISHED - HIGH STRENGTH - MADE IN USA	5-1322	395.50
TWELVE POINT - POLISHED - HIGH STRENGTH - MADE IN USA	5-1323	436.50

# KITS FOR 4.3 LITER V6 CHEVY ENGINES

**ENGINE KITS-** Every engine kit includes component kits for the Distributor, Fuel Pump, Intake Manifold, Oil Pan, Thermostat Housing, Timing Cover, Valve Covers, and Water Pump. Available in 5 different bolt styles and includes 125 pieces!

ENGINE KITS WITH:	CENTER BOLT VALVE COVERS	CAST VALVE COVERS	SHEET METAL VALVE COVERS	Price
BUTTON HEAD		# 6-5422	#6-5400	\$ 55.00
BUTTON HEAD	# 6-5466			57.00
HEX HEAD		6-5423	6-5401	57.00
HEX HEAD	6-5415			59.75
SOCKET HEAD		6-5424	6-5402	64.75
SOCKET HEAD	6-5416			67.00
SIX POINT - POLISHED - HIGH STRENGTH		6-5425	6-5403	280.00
SIX POINT - POLISHED	6-5440			300.00
TWELVE POINT - POLISHED - HIGH STRENGTH		6-5426	6-5404	310.50
TWELVE POINT - POLISHED	6-5441			330.50

\*\* NOTE SIX POINT & TWELVE POINT BOLTS ARE MADE IN USA \*\*

## ACCESSORY KITS (NOT INCLUDED IN THE ENGINE KIT)

**BELLHOUSING KITS** - SEE PAGE 29

**ENGINE MOUNT KIT** - MOUNTS TO BLOCK

SIX POINT - HIGH STRENGTH # 6-5113 \$ 33.50  
TWELVE POINT - HIGH STRENGTH 6-5114 35.50

\*7/16-14 PIVOT BOLTS NOT INCLUDED - MEASURE THE LENGTH AND ORDER (2) 6 OR 12 POINT BOLTS & NUTS\*

### EXHAUST BOLT KITS

-HEADERS: SEE 12 COUNT KITS- PAGES 6 & 7

-STOCK EXHAUST:

SIX POINT - HIGH STRENGTH 6-5420 102.50  
TWELVE POINT - HIGH STRENGTH 6-5421 107.50

**CARB MOUNT KITS** - SEE PAGE 7

**STARTER KITS**-WITH KNURLED BOLTS 3 3/4" LONG  
BOLTS: ALSO AVAILABLE IN 4", 4-1/4", & 4-1/2" SEE PG 22.

SIX POINT - HIGH STRENGTH # 6-5456 \$ 35.00  
TWELVE POINT - HIGH STRENGTH 6-5454 37.50

**FAN PULLEY KITS** - 3/4" LONG BOLTS

- STEEL PULLEYS WITHOUT A SPACER:

SIX POINT - HIGH STRENGTH 6-5609 19.50  
TWELVE POINT - HIGH STRENGTH 6-5607 20.50

- ALUMINUM PULLEYS: WITH COUNTERSUNK HOLES  
AND NO FAN BLADE

FLAT SOCKET 6-5608 5.25

# KITS FOR CHEVY LS ENGINES

**ENGINE KITS-** Every engine kit includes component kits for the Coil & Harness, Intake Manifold, Oil Pan, Sensor, Thermostat, Timing Cover, Valley Cover, Valve Cover, & Water Crossover.

NOTE: On the Valve Covers, tap the stock bolts out of the original tubes & REUSE the tubes.

Contains one of each component kit	1997 & 1998	Price	1999 & UP	Price
BUTTON/SOCKET HEAD	# 5-1500	\$ 107.00	# 5-1520	\$ 106.00
SOCKET HEAD	5-1501	105.50	5-1521	103.75
SIX POINT - POLISHED - HIGH STRENGTH	5-1550	747.00	5-1552	658.50
TWELVE POINT - POLISHED - HIGH STRENGTH	5-1551	799.00	5-1553	735.50

\*\* NOTE SIX POINT & TWELVE POINT BOLTS ARE MADE IN USA \*\*

## ACCESSORY KITS (NOT INCLUDED IN THE ENGINE KIT)

### BELLHOUSING KITS

- 5 BOLT TYPE:

HEX HEAD - MEDIUM STRENGTH # 5-1532 \$ 21.00  
SOCKET HEAD - MEDIUM STRENGTH 5-1530 23.75  
SIX POINT - HIGH STRENGTH 5-1574 51.50  
TWELVE POINT - HIGH STRENGTH 5-1575 52.50

- 7 BOLT TYPE:

HEX HEAD - MEDIUM STRENGTH 5-1533 26.75  
SOCKET HEAD - MEDIUM STRENGTH 5-1531 32.00  
SIX POINT - HIGH STRENGTH 5-1582 71.50  
TWELVE POINT - HIGH STRENGTH 5-1583 75.50

### EXHAUST KITS

- SEE 12 & 16 COUNT 8MM KITS ON PAGES 6 & 7

### ENGINE MOUNT KITS

3 BOLT TYPE MOUNTS (35MM LONG BOLTS):

SIX POINT - HIGH STRENGTH # 5-1576 \$ 60.00  
TWELVE POINT - HIGH STRENGTH 5-1577 63.00

4 BOLT TYPE MOUNTS (25MM LONG BOLTS):

SIX POINT - HIGH STRENGTH 5-1586 52.50  
TWELVE POINT - HIGH STRENGTH 5-1587 58.00

### STARTER KITS

-WITH KNURLED BOLTS

(1) SHORT (45 MM) & (1) 114 MM LONG BOLT

SIX POINT - HIGH STRENGTH # 5-1594 \$ 32.50

(2) 114MM LONG BOLTS

SIX POINT - HIGH STRENGTH 5-1588 33.50

### OIL PAN PLUGS

-WITH QUAD-SEAL O-RINGS

BUTTON HEAD (LOW PROFILE) 1-6004 13.00

SIX POINT - HIGH STRENGTH 1-6006 20.50

TWELVE POINT - HIGH STRENGTH 1-6007 21.00

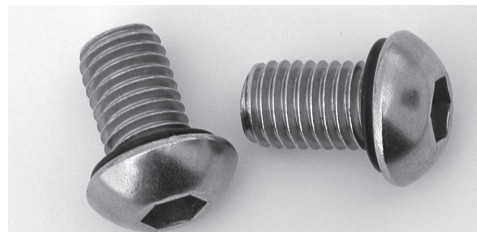

**ENGINE KITS  
FOR CHEVY SMALL  
BLOCK ENGINES**  
265-283-305-307-327-350-400

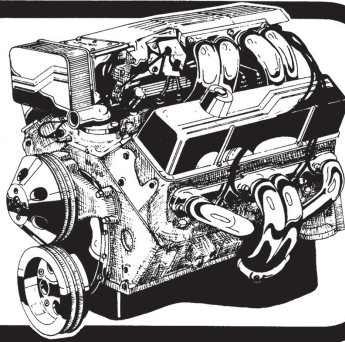

**ENGINE KITS-** Each engine kit includes component kits for the Distributor, Fuel Pump (except TPI engines), Intake, Sheet Metal Oil Pan, Thermostat, Sheet Metal Timing Cover, Valve Covers, and Water Pump.

\*\*\*PLEASE STATE IF YOU HAVE A CAST OIL PAN (OR ONE WITH REINFORCED SIDE RAILS) OR A CAST TIMING COVER\*\*\*

\* NOTE INDENTED HEX, SIX POINT & 12 POINT BOLTS ARE MADE IN USA \*      FOR ENGINES WITH LONG WATER PUMPS      FOR ENGINES WITH SHORT WATER PUMPS      PRICE:

**KITS WITH CAST ALUMINUM VALVE COVERS**

BUTTON HEAD	# 6-5643	# 6-5652	\$ 51.00
HEX HEAD	6-5644	6-5653	57.00
HEX/INDENTED HEX HEAD - ORIGINAL STYLE FOR ENGINES 55-62 WITH INDENTED HEX BOLTS USED WHERE APPROPRIATE			
		6-5657	68.75
HEX/INDENTED HEX - ORIGINAL STYLE: 63 & UP	6-5696	6-5697	124.00
SOCKET HEAD	6-5645	6-5654	65.50
SIX POINT - POLISHED - HIGH STRENGTH	6-5646	6-5655	299.00
TWELVE POINT - POLISHED - HIGH STRENGTH	6-5647	6-5656	325.00

**KITS WITH SHEET METAL, STOCK, CHROME VALVE COVERS**

BUTTON HEAD	6-5002	6-5660	51.00
HEX HEAD	6-5000	6-5661	57.00
HEX/INDENTED HEX - ORIGINAL STYLE: 55-62			
	6-5698	6-5005	122.75
HEX/INDENTED HEX - ORIGINAL STYLE: 63 & UP			
	6-5699	6-5662	124.00
SOCKET HEAD	6-5001	6-5663	67.00
SIX POINT - POLISHED - HIGH STRENGTH	6-5071	6-5664	299.00
TWELVE POINT - POLISHED - HIGH STRENGTH	6-5072		321.50

**KITS WITH CENTER BOLT VALVE COVERS**

BUTTON HEAD	6-5498	6-5499	61.00
HEX HEAD	6-5097	6-5667	67.00
SOCKET HEAD	6-5642	6-5668	71.00
SIX POINT - POLISHED - HIGH STRENGTH	6-5444	6-5446	325.00
TWELVE POINT - POLISHED - HIGH STRENGTH	6-5445	6-5447	350.50

**KITS FOR TPI ENGINES WITH CAST ALUMINUM VALVE COVERS**

BUTTON HEAD	6-5648	6-5658	87.00
SOCKET HEAD	6-5649	6-5659	95.00
SIX POINT - POLISHED - HIGH STRENGTH	6-5459	6-7895	535.50
TWELVE POINT - POLISHED - HIGH STRENGTH	6-5460	6-7896	576.50

**KITS FOR TPI ENGINES WITH SHEET METAL VALVE COVERS**

BUTTON HEAD	6-5080	6-5665	87.00
SOCKET HEAD	6-5129	6-5666	95.00
SIX POINT - POLISHED - HIGH STRENGTH	6-5461	6-7897	535.50
TWELVE POINT - POLISHED - HIGH STRENGTH	6-7966	6-7967	576.50

**KITS FOR TPI ENGINES WITH CENTER BOLT VALVE COVERS**

BUTTON HEAD	6-5650	6-5669	91.00
SOCKET HEAD	6-5651	6-5670	98.50
SIX POINT - POLISHED - HIGH STRENGTH	6-7898	6-7968	562.00
TWELVE POINT - POLISHED - HIGH STRENGTH	6-5464	6-7894	599.00

**KITS FOR LT-1/LT-4 TPI ENGINES WITH CENTER BOLT VALVE COVERS**

BUTTON HEAD		6-5437	91.00
SOCKET HEAD		6-5438	96.50
SIX POINT - POLISHED - HIGH STRENGTH		6-5473	453.50
TWELVE POINT - POLISHED - HIGH STRENGTH		6-5474	493.00

**KITS FOR "VORTEC" ENGINES**

BUTTON HEAD	6-5475		52.00
HEX HEAD	6-5476		58.00
INDENTED HEX HEAD - ORIGINAL STYLE			
	6-8299		99.00
SOCKET HEAD	6-5477		61.00
SIX POINT - POLISHED - HIGH STRENGTH	6-5478		299.00
TWELVE POINT - POLISHED - HIGH STRENGTH	6-5479		332.50

**TOLL FREE ORDER LINE : 1-800-767-4781**



# 22 ACCESSORY KITS FOR SMALL BLOCK CHEVY ENGINES

(NOT INCLUDED IN ENGINE KITS - EXCEPT L89 TPI INTAKE KITS)

**BELLHOUSING KITS** - SEE PAGE 29

**CARB MOUNT KITS** - SEE PAGE 7

**CRANK PULLEY KITS - 3/4" LONG BOLTS**

SIX POINT - HIGH STRENGTH	# 6-5620	\$ 16.00
TWELVE POINT - HIGH STRENGTH	6-5160	17.00

**ENGINE MOUNT KITS** - MOUNTS TO BLOCK -

\* 7/16-14 PIVOT BOLTS NOT INCLUDED - MEASURE THE LENGTH AND ORDER (2) 6 OR 12 POINT BOLTS & NUTS \*

SIX POINT - HIGH STRENGTH	6-5113	33.50
TWELVE POINT - HIGH STRENGTH	6-5114	35.50

**EXHAUST BOLT KITS**

**- 2 1/4" LONG BOLTS** - (FOR STOCK SBC, EXCEPT RAMS HORN) STUDS NOT INCLUDED

HEX HEAD - HAS STOCK APPEARANCE, BUT NOT AS STRONG AS STOCK	6-5051	23.25
SIX POINT - HIGH STRENGTH	6-5052	105.00
TWELVE POINT - HIGH STRENGTH	6-5056	107.50

**- MANIFOLD KITS FOR CHEVY V8 RAMS HORN**

-INCLUDES BOLTS FOR COLLECTOR FLANGES:

HEX HEAD-HAS STOCK APPEARANCE, BUT NOT AS STRONG AS STOCK	6-5006	33.00
SIX POINT - HIGH STRENGTH	6-5007	154.50
TWELVE POINT - HIGH STRENGTH	6-5008	162.00

-INCLUDES STUDS FOR COLLECTOR FLANGES:

HEX HEAD	6-5594	72.25
SIX POINT/HEX NUTS - HIGH STRENGTH	6-5595	174.50
12 POINT/12 PT NUTS - HIGH STRENGTH	6-5596	180.50

**- 12 COUNT HEADER KITS SEE PAGES 6 & 7**

**STUD BOLT FOR EXHAUST** 3/8-16 X 2-1/4

HIGH STRENGTH 17-4 PH STAINLESS WITH A 3/8-16 X 1" STUD ON TOP	2-7108	20.00
--	--------	-------

**HEAD BOLT KITS**

-COMPLETE(INSIDE & OUTSIDE) SET

SIX POINT - HIGH STRENGTH	6-5677	356.00
TWELVE POINT - HIGH STRENGTH	6-5678	399.00

-OUTSIDE BOLTS ONLY

SIX POINT - HIGH STRENGTH	6-5066	143.50
TWELVE POINT - HIGH STRENGTH	6-5169	151.50

**HEAD BOLT WASHERS FOR ALUMINUM HEADS**

(SPECIAL GROUND AND BEVELED WASHERS BY ARP)

OUTSIDE SET	6-5621	41.50
COMPLETE SET	6-5622	85.50

**HARMONIC BALANCER BOLT KITS**

**-HEAVY DUTY WASHER WITH 2" LONG BOLT**

SIX POINT - HIGH STRENGTH	6-5482	26.00
TWELVE POINT - HIGH STRENGTH	6-5483	28.00

**-HEAVY DUTY WASHER WITH 2 1/4" LONG BOLT**

SIX POINT - HIGH STRENGTH	6-5480	26.50
TWELVE POINT - HIGH STRENGTH	6-5481	28.50

**-HEAVY DUTY WASHER WITH 2 1/2" LONG BOLT**

SIX POINT - HIGH STRENGTH	6-5484	27.00
TWELVE POINT - HIGH STRENGTH	6-5485	29.00

**-UNIVERSAL KIT WITH HEAVY DUTY WASHER & (1) EACH 2", 2 1/4", & 2 1/2" LONG BOLTS**

SIX POINT - HIGH STRENGTH	6-5487	47.00
TWELVE POINT - HIGH STRENGTH	6-5488	48.00

**FAN PULLEY KIT**- SEE PAGE 23 (Same as BBC)

**BASIC L89 TPI KITS** - INCLUDED IN TPI ENGINE KITS:

INCLUDES ALL BOLTS FROM MANIFOLD UP (ALL METRIC)		
DOES NOT INCLUDE MANIFOLD TO HEAD BOLTS		
BUTTON HEAD	# 6-5010	\$ 39.50
SOCKET HEAD	6-5081	41.25
SIX POINT - HIGH STRENGTH	6-5457	251.00
TWELVE POINT - HIGH STRENGTH	6-5458	275.00

**KITS FOR RAM JET TPI INTAKE**

BUTTON HEAD	6-5580	15.50
HEX HEAD	6-5462	16.75
SIX POINT - HIGH STRENGTH	6-5463	64.00
TWELVE POINT - HIGH STRENGTH	6-7899	74.00

**OIL & TRANSMISSION PAN PLUG**

TRUSS SOCKET HEAD	7-0402	23.50
-------------------	--------	-------



**STARTER KITS** - WITH KNURLED BOLTS

**- LOW TORQUE: 1 LONG & 1 SHORT BOLT**

HEX HEAD	6-5068	18.00
SIX POINT - HIGH STRENGTH	6-5152	34.00
TWELVE POINT - HIGH STRENGTH	6-5671	35.00

**- HIGH TORQUE STARTERS:**

**WITH 3 3/4" LONG BOLTS:**

SIX POINT - HIGH STRENGTH	6-5456	34.50
TWELVE POINT - HIGH STRENGTH	6-5454	37.00

**WITH 4" LONG BOLTS:**

SIX POINT - HIGH STRENGTH	6-5450	38.50
TWELVE POINT - HIGH STRENGTH	6-5451	39.00

**WITH 4 1/4" LONG BOLTS:**

SIX POINT - HIGH STRENGTH	6-7983	35.50
TWELVE POINT - HIGH STRENGTH	6-7984	37.50

**WITH 4.5" LONG BOLTS**

HEX HEAD	6-5048	19.00
SIX POINT - HIGH STRENGTH	6-5171	43.50
TWELVE POINT - HIGH STRENGTH	6-5232	45.00

**SERPENTINE BELT DRIVE KITS FOR CHEVY/GMC TRUCKS & SUV'S WITH 350 V8 ENGINES -1990-95:**

BUTTON & SOCKET HEAD	6-1565	70.75
HEX & INDENTED HEX HEAD	6-1566	78.00
SOCKET HEAD	6-1567	78.25
SIX POINT - HIGH STRENGTH	6-1568	181.50
TWELVE POINT - HIGH STRENGTH	6-1569	192.50

**-1996-98 C/K TRUCKS & 1996-2000 FULL SIZE SUV'S**

HEX HEAD	6-1571	36.25
SOCKET HEAD	6-1572	42.75
SIX POINT - HIGH STRENGTH	6-1579	94.00
TWELVE POINT - HIGH STRENGTH	6-1570	99.00

**STUD BOLT FOR INTAKE** 3/8-16 X 1-1/4" HIGH

STRENGTH 17-4 PH STAINLESS WITH A

3/8-16 x 3/4" STUD ON TOP	2-7106	18.50
---------------------------	--------	-------

**STUD BOLTS FOR WATER PUMP**

3/8-16 X 1-3/4" HIGH STRENGTH 17-4 PH STAINLESS WITH A		
3/8-16 x 7/8" STUD ON TOP	2-7110	19.00
3/8-16 X 2" HIGH STRENGTH 17-4 PH STAINLESS WITH A		
3/8-16 x 1" STUD ON TOP	2-6994	19.50

**BUTTON**

**HEX**

**INDENTED HEX (ORIGINAL STYLE)**

**SOCKET**

**6-POINT**

**12-POINT**

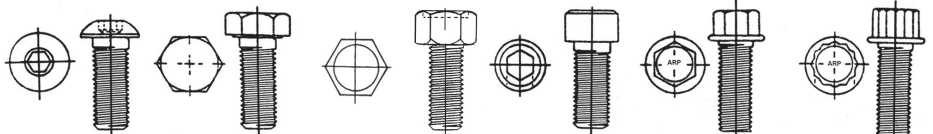



# KITS FOR BIG BLOCK CHEVY ENGINES

Each engine kit includes component kits for the Distributor, Fuel Pump, Intake, Oil Pan, Thermostat, Timing Cover, Valve Covers, and Water Pump.

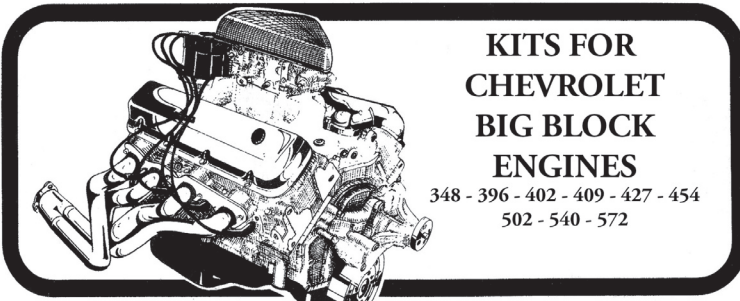

## KITS FOR CHEVROLET BIG BLOCK ENGINES

348 - 396 - 402 - 409 - 427 - 454  
502 - 540 - 572

\* NOTE INDENTED HEX, SIX POINT & 12 POINT BOLTS ARE MADE IN USA \*

FOR ENGINES WITH CAST VALVE COVERS

FOR ENGINES WITH SHEET METAL VALVE COVERS

PRICE:

### 348 - 409

	#		PRICE:
BUTTON HEAD	# 6-5672	# 6-5600	\$ 51.00
HEX INDENTED HEX - ORIGINAL STYLE	6-5605	6-5606	153.00
SOCKET HEAD	6-5674	6-5602	63.50
SIX POINT - POLISHED - HIGH STRENGTH	6-5675	6-5603	341.50
TWELVE POINT - POLISHED - HIGH STRENGTH	6-5676	6-5604	367.50

### 396 - 402 - 427 - 454 KITS WITH LONG WATER PUMP

BUTTON HEAD	6-5680	6-5102	52.50
HEX/INDENTED HEX - ORIGINAL STYLE	6-5115	6-5116	160.00
SOCKET HEAD	6-5682	6-5101	65.75
SIX POINT - POLISHED - HIGH STRENGTH	6-5683	6-5162	355.50
TWELVE POINT - POLISHED - HIGH STRENGTH	6-5684	6-5163	382.50

### 396 - 402 - 427 - 454 KITS WITH SHORT WATER PUMP

BUTTON HEAD	6-5685	6-5690	54.50
HEX/INDENTED HEX - ORIGINAL STYLE	6-5132	6-5133	155.00
SOCKET HEAD	6-5687	6-5692	65.75
SIX POINT - POLISHED - HIGH STRENGTH	6-5688	6-5693	357.00
TWELVE POINT - POLISHED - HIGH STRENGTH	6-5689	6-5694	383.50

### 502 (GEN 5) WITH STANDARD LONG PUMP

BUTTON HEAD	6-7987		59.00
HEX/INDENTED HEX HEAD - ORIGINAL STYLE	6-7989		155.00
SOCKET HEAD	6-7990		72.75
SIX POINT - POLISHED - HIGH STRENGTH	6-7991		356.00
TWELVE POINT - POLISHED - HIGH STRENGTH	6-7992		365.00

### 502 - 540 - 572 (GEN 6) - WITH STANDARD LONG PUMP

BUTTON HEAD	6-7960		61.00
HEX/INDENTED HEX HEAD - ORIGINAL STYLE	6-7962		150.00
SOCKET HEAD	6-7963		73.50
SIX POINT - POLISHED - HIGH STRENGTH	6-7964		364.00
TWELVE POINT - POLISHED - HIGH STRENGTH	6-7965		384.50

## ACCESSORY KITS (NOT INCLUDED IN THE ENGINE KIT)

### CRANK PULLEY KITS - 3/4" LONG BOLTS

SIX POINT - HIGH STRENGTH	# 6-7976	\$ 16.00
TWELVE POINT - HIGH STRENGTH	6-7975	17.50

### EXHAUST BOLT KITS

- 348-409 SEE 14 COUNT BOLT KITS ON PAGES 6 & 7  
- 396-572 SEE 16 COUNT BOLT KITS ON PAGES 6 & 7

### OUTSIDE HEAD BOLT KITS

#### -348/409

SIX POINT - HIGH STRENGTH	6-5635	163.00
TWELVE POINT - HIGH STRENGTH	6-7973	177.25

#### -396-402-427-454 ONLY

SIX POINT - HIGH STRENGTH	6-5112	207.95
TWELVE POINT - HIGH STRENGTH	6-5452	219.85

#### -502-540-572 (WITH SPECIAL HEADBOLT WASHERS)

SIX POINT - HIGH STRENGTH	6-7985	307.50
TWELVE POINT - HIGH STRENGTH	6-7986	311.50

### HARMONIC BALANCER KIT

-FOR ENGINES WITH A 2 1/2" LONG BOLT

SIX POINT - HIGH STRENGTH	6-5491	31.00
TWELVE POINT - HIGH STRENGTH	6-7972	32.50

### BELLHOUSING KITS - SEE PAGE 29

### CARB MOUNT KITS - SEE PAGE 7

### ENGINE MOUNT KITS - MOUNTS TO BLOCK -

7/16-14 PIVOT BOLTS NOT INCLUDED - MEASURE THE LENGTH AND ORDER (2) 6 OR 12 POINT BOLTS & NUTS  
SIX POINT - HIGH STRENGTH # 6-5113 \$ 33.50  
TWELVE POINT - HIGH STRENGTH 6-5114 35.50

### FAN PULLEY KITS - 3/4" LONG BOLTS

-STEEL PULLEYS WITHOUT A SPACER:

SIX POINT - HIGH STRENGTH	6-5609	19.50
TWELVE POINT - HIGH STRENGTH	6-5607	20.50

-ALUMINUM PULLEYS: WITH COUNTERSUNK HOLES AND NO FAN BLADE:

FLAT SOCKET	6-5608	5.25
-------------	--------	------

### STARTER BOLTS - KNURLED BOLTS

-HIGH TORQUE AFTERMARKET STARTERS: 4" LONG BOLTS

SIX POINT - HIGH STRENGTH	6-5450	38.50
TWELVE POINT - HIGH STRENGTH	6-5451	39.00

-STOCK 502 STARTERS: 4 1/4" BOLTS

SIX POINT - HIGH STRENGTH	6-7983	35.50
TWELVE POINT - HIGH STRENGTH	6-7984	37.50

-HIGH TORQUE STOCK STARTER: 4 1/2" LONG BOLTS

HEX HEAD	6-5048	19.00
SIX POINT - HIGH STRENGTH	6-5171	43.50
TWELVE POINT - HIGH STRENGTH	6-5232	45.00

**TOLL FREE ORDER LINE : 1-800-767-4781**

# KITS FOR OLDSMOBILE ENGINES: 260 thru 455

Each engine kit includes component kits for the Distributor, Fuel Pump, Intake, Oil Filter, Oil Pan, Thermostat, Timing Cover, Valve Covers, and Water Pump.

<b>** NOTE INDENTED HEX, SIX POINT &amp; 12 POINT BOLTS ARE MADE IN USA **</b>	<b>FOR ENGINE WITH CAST VALVE COVERS</b>	<b>FOR ENGINES WITH SHEET METAL VALVE COVERS</b>	<b>PRICE:</b>
BUTTON HEAD	# 6-5390	# 6-5300	\$ 60.50
INDENTED/HEX HEAD - ORIGINAL STYLE	6-5398	6-5399	139.00
SOCKET HEAD	6-5392	6-5302	68.75
SIX POINT - POLISHED - HIGH STRENGTH	6-5393	6-5384	342.00
TWELVE POINT - POLISHED - HIGH STRENGTH	6-5394	6-5385	375.00

## ACCESSORY KITS (NOT INCLUDED IN THE ENGINE KIT)

**BELLHOUSING KITS** -SEE PAGE 29

### CRANK PULLEY KITS

SIX POINT - HIGH STRENGTH	# 6-5334	\$17.50
TWELVE POINT - HIGH STRENGTH	6-5335	18.75

### EXHAUST BOLT KITS

- SEE 10 COUNT BOLT KITS ON PAGES 6 & 7

### STARTER KITS - WITH KNURLED BOLTS: HIGH TORQUE - 4-1/2" LONG BOLTS

HEX HEAD	6-5048	19.00
SIX POINT - HIGH STRENGTH	6-5171	43.50
TWELVE POINT - HIGH STRENGTH	6-5232	45.00

### LOW TORQUE STARTER - 2" & 4" LONG BOLTS

HEX HEAD	6-5332	17.00
SIX POINT - HIGH STRENGTH	6-5396	40.00
TWELVE POINT - HIGH STRENGTH	6-5397	41.50

### STUD BOLT KIT FOR WATER PUMP

(2) 5/16 X 1 1/2" & (1) 2 1/2" stud bolts	6-3896	46.75
---	--------	-------

**CARB MOUNT KITS** - SEE PAGE 7

### ENGINE MOUNT KITS

SIX POINT - HIGH STRENGTH	# 6-5350	\$ 39.25
TWELVE POINT - HIGH STRENGTH	6-5351	36.75

### HARMONIC BALANCER KIT - WITH BILLET WASHER

SIX POINT - HIGH STRENGTH	6-3895	98.50
---------------------------	--------	-------

### HEAT RISER & EGR VALVE KITS

BUTTON HEAD	6-5336	7.00
INDENTED HEX	6-5379	9.75
SOCKET HEAD	6-5338	7.75
SIX POINT - HIGH STRENGTH	6-5343	20.00
TWELVE POINT - HIGH STRENGTH	6-5344	21.50

### OUTSIDE HEAD BOLT KITS -1976 AND EARLIER

SIX POINT - HIGH STRENGTH	6-5395	124.25
TWELVE POINT - HIGH STRENGTH	6-5352	131.25

### STUD BOLT & BUSHING FOR TIMING COVER

	6-3897	26.00
--	--------	-------

# KITS FOR OLDS ROCKET ENGINES

Each engine kit includes component kits for the Crankcase Breather, Distributor, Fuel Pump, Intake, Oil Filter Housing, Oil Pan, Temperature Sensor, Thermostat, Timing Cover, Valley Cover, Valve Covers, and Water Pump.

**\*\* NOTE INDENTED HEX, SIX POINT & 12 POINT BOLTS ARE MADE IN USA \*\***

### 303/324/371 (THRU 1958)

BUTTON HEAD	# 6-4300	Price: \$ 79.00	WITH AN EDELBROCK 3-2'S INTAKE:	# 6-4425	Price: \$ 75.00
HEX HEAD	6-4301	79.00		6-4426	75.00
SOCKET HEAD	6-4302	95.75		6-4427	89.00
SIX POINT - POLISHED - HIGH STRENGTH	6-4303	426.50		6-4428	392.00
TWELVE POINT - POLISHED - HIGH STRENGTH	6-4304	444.00		6-4429	426.00

### 371 & 394 (1959-60)

BUTTON HEAD	# 6-4450	
HEX HEAD	6-4451	
SOCKET HEAD	6-4452	
SIX POINT - POLISHED - HIGH STRENGTH	6-4453	
TWELVE POINT - POLISHED - HIGH STRENGTH	6-4454	

### 394 (1961-64)

BUTTON HEAD	6-4430	
HEX HEAD	6-4431	
SOCKET HEAD	6-4432	
SIX POINT - POLISHED - HIGH STRENGTH	6-4433	
TWELVE POINT - POLISHED - HIGH STRENGTH	6-4434	

FOR ENGINES WITH CAST VALVE COVERS

FOR ENGINES WITH SHEET METAL VALVE COVERS



**ROCKET 394 IN A HENRY J**

# 6-4305	Price: \$ 79.00
6-4306	79.00
6-4307	80.00
6-4308	444.00
6-4309	475.00
6-4400	73.00
6-4401	77.00
6-4402	80.00
6-4403	403.00
6-4404	423.00

## ACCESSORY KITS (NOT INCLUDED IN THE ENGINE KIT)

### BELLHOUSING KITS

SIX POINT - HIGH STRENGTH	# 6-4410	\$ 75.50
TWELVE POINT - HIGH STRENGTH	6-4411	76.50

### HARMONIC BALANCER KITS

SIX POINT - HIGH STRENGTH	6-4424	25.50
---------------------------	--------	-------

### OUTSIDE HEADBOLT KITS

SIX POINT - HIGH STRENGTH	6-4423	233.00
---------------------------	--------	--------

### STARTER KITS

HEX HEAD	6-4416	6.00
SOCKET HEAD	6-4417	8.00
SIX POINT - HIGH STRENGTH	6-4456	19.50
TWELVE POINT - HIGH STRENGTH	6-4457	20.50

**EXHAUST BOLT KITS** - SEE 12 COUNT BOLT KITS ON PAGES 6 & 7 STOCK EXHAUST KIT:

HEX HEAD WITH STUDS & WEDGE LOCKS	# 6-4458	\$ 94.00
-----------------------------------	----------	----------

### INTAKE WASHERS - 1.35" OD

SET OF (4) 1/4" THICK - MADE IN USA	6-4459	43.50
-------------------------------------	--------	-------

### FRONT ENGINE MOUNT KITS

SIX POINT - HIGH STRENGTH	6-4408	22.00
TWELVE POINT - HIGH STRENGTH	6-4409	23.50

### STARTER/FLYWHEEL HOUSING KITS

HEX HEAD	6-4414	14.50
----------	--------	-------

**CARB MOUNT KITS** - SEE PAGE 7

# KITS FOR PONTIAC V8 ENGINES

Each engine kit includes component kits for the Distributor, Fuel Pump, Intake, Oil Filter, Oil Pan, Thermostat, Timing Cover, Valve Covers, and Water Pump.

\*\* NOTE INDENTED HEX, SIX POINT & FOR ENGINE WITH FOR ENGINES WITH SHEET  
12 POINT BOLTS ARE MADE IN USA \*\* CAST VALVE COVERS METAL VALVE COVERS PRICE:

## ENGINE KITS FOR 287 - 317 - 347 - 370 - 389 (1960 & EARLIER)

BUTTON AND SOCKET HEAD	# 6-2850	# 6-2885	\$ 61.75
HEX HEAD	6-2851	6-2886	67.00
SOCKET HEAD	6-2852	6-2887	68.00
SIX POINT - POLISHED - HIGH STRENGTH	6-2853	6-2888	313.00
TWELVE POINT - POLISHED - HIGH STRENGTH	6-2854	6-2889	348.50

## ENGINE KITS FOR 326 - 350 - 389 (1961 & UP) - 400 - 421 - 428 - 455

BUTTON AND SOCKET HEAD	# 6-5260	# 6-5200	\$ 59.50
HEX HEAD	6-5261	6-5201	67.00
HEX/INDENTED HEX - ORIGINAL STYLE	6-5280	6-5281	116.00
SOCKET HEAD	6-5262	6-5202	68.00
SIX POINT - POLISHED - HIGH STRENGTH	6-5265	6-5267	313.50
TWELVE POINT - POLISHED - HIGH STRENGTH	6-5266	6-5268	349.50

## ACCESSORY KITS (NOT INCLUDED IN THE ENGINE KIT)

**BELLHOUSING KITS** - SEE PAGE 29

**CARB MOUNT KITS** - SEE PAGE 7

**CRANK PULLEY KITS** - 1967 & UP

SIX POINT - HIGH STRENGTH	# 6-5291	\$18.50
TWELVE POINT - HIGH STRENGTH	6-5273	20.00

**ENGINE MOUNT KITS**

SIX POINT - HIGH STRENGTH	6-5276	28.50
TWELVE POINT - HIGH STRENGTH	6-5277	30.50

**FAN PULLEY KITS** - 3/4" LONG BOLTS

-STEEL PULLEYS WITHOUT A SPACER:		
SIX POINT - HIGH STRENGTH	6-5609	19.50
TWELVE POINT - HIGH STRENGTH	6-5607	20.50

-ALUMINUM PULLEYS: WITH NO FAN BLADE:

FLAT SOCKET	6-5608	5.25
-------------	--------	------

**EXHAUST BOLT KITS** - SEE 12 COUNT BOLT KITS  
ON PAGES 6 & 7

**HARMONIC BALANCER KIT** - WITH BILLET WASHER

SIX POINT - HIGH STRENGTH	# 6-5235	\$ 62.00
---------------------------	----------	----------

**OUTSIDE HEAD BOLT KITS**

SIX POINT - HIGH STRENGTH	6-5253	148.50
TWELVE POINT - HIGH STRENGTH	6-5274	150.00

**HEAD BOLT WASHERS FOR ALUMINUM HEADS**

OUTSIDE SET (10) 17-4 PH WASHERS	6-9026	58.50
----------------------------------	--------	-------

**STUD BOLT FOR INTAKE** 3/8-16 WITH

5/16-18 X 5/8" STUD ON TOP	2-7020	20.00
----------------------------	--------	-------

**STARTER KITS - WITH KNURLED 4" BOLTS**

SIX POINT - HIGH STRENGTH	6-5450	38.50
TWELVE POINT - HIGH STRENGTH	6-5451	39.00

**KITS FOR OVERHEAD CAM SIX CYLINDER - SEE PAGE 28!**

# KITS FOR 304-345-392 INTERNATIONAL ENGINES

**ENGINE KITS**- Every engine kit includes component kits for the Distributor, Fuel Pump, Intake, Oil Filter, Oil Pan, Thermostat, Timing Cover, Valley Cover, Valve Covers, and Water Pump.

BUTTON & SOCKET HEAD	# 6-3900	\$ 70.00
HEX HEAD	6-3901	71.00
HEX & INDENTED HEX HEAD - ORIGINAL STYLE	6-3902	141.00
SOCKET HEAD	6-3903	83.50
SIX POINT - POLISHED - HIGH STRENGTH	6-3904	387.50
TWELVE POINT - POLISHED - HIGH STRENGTH	6-3905	419.50

\*\* NOTE INDENTED HEX, SIX POINT & TWELVE POINT BOLTS ARE MADE IN USA \*\*

## ACCESSORY KITS: (NOT INCLUDED IN THE ENGINE KIT)

**BELLHOUSING KITS** - FOR 727 TORQUEFLITE

HEX HEAD	# 6-3977	\$ 21.00
SOCKET HEAD	6-3973	21.75
SIX POINT - HIGH STRENGTH	6-3974	88.50

**EXHAUST BOLT KITS**

- SEE 10 COUNT 3/8" BOLT KITS ON PAGES 6 & 7  
- STOCK EXHAUST:

HEX HEAD	6-3962	22.00
SIX POINT - HIGH STRENGTH	6-3963	109.50

**ENGINE MOUNT KITS** -FOR CAST FRONT MOUNT

SIX POINT - HIGH STRENGTH	6-3965	37.52
-FOR SIDE MOUNTS: 6 PT - HIGH STRENGTH	6-3975	52.50

**CARB MOUNT KITS** - SEE PAGE 7

**FAN PULLEY KITS**

SIX POINT - HIGH STRENGTH	#6-3971	\$20.50
TWELVE POINT - HIGH STRENGTH	6-3972	21.50

**HARMONIC BALANCER KIT** - WITH BILLET WASHER

SIX POINT - HIGH STRENGTH	6-3976	65.00
---------------------------	--------	-------

**STARTER KITS**

HEX HEAD	6-3967	6.00
SOCKET HEAD	6-3968	7.50
SIX POINT - HIGH STRENGTH	6-3969	20.50
TWELVE POINT - HIGH STRENGTH	6-3970	22.50

**ENGINE KITS FOR  
SMALL BLOCK MOPAR**  
273-318-340-360  
CHRYSLER/DODGE/PLYMOUTH

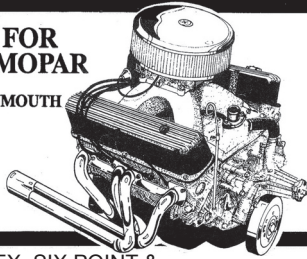

# KITS FOR SMALL BLOCK MOPAR

Each engine kit includes component kits for the Distributor, Fuel Pump, Intake, Oil Pan, Thermostat, Valve Covers, and Water Pump.

\* NOTE INDENTED HEX, SIX POINT & TWELVE POINT BOLTS ARE MADE IN USA \*

FOR ENGINES WITH  
CAST VALVE COVERS

FOR ENGINES WITH SHEET  
METAL VALVE COVERS

PRICE:

**ENGINE KITS FOR 273 - 318 - 340 - UP THRU 1991 - 360 - UP THRU 1992**

	FOR ENGINES WITH CAST VALVE COVERS	FOR ENGINES WITH SHEET METAL VALVE COVERS	PRICE:
BUTTON & SOCKET HEAD	# 6-3033	# 6-3000	\$ 72.75
HEX/INDENTED HEX - ORIGINAL STYLE	6-3246	6-3241	106.00
SOCKET HEAD	6-3234	6-3002	79.00
SIX POINT - POLISHED - HIGH STRENGTH	6-3094	6-3213	332.50
TWELVE POINT - POLISHED - HIGH STRENGTH	6-3237	6-3214	354.50

**ENGINE KITS FOR 5.2L (318, 1992 & UP) & 5.9L (360, 1993 & UP) FUEL INJECTED**

	FOR ENGINES WITH CAST VALVE COVERS	FOR ENGINES WITH SHEET METAL VALVE COVERS	PRICE:
BUTTON & SOCKET HEAD	6-3250	6-3256	79.00
INDENTED HEX HEAD - ORIGINAL STYLE	6-3252	6-3258	112.00
SOCKET HEAD	6-3253	6-3259	87.00
SIX POINT - POLISHED - HIGH STRENGTH	6-3254	6-3262	399.00
TWELVE POINT - POLISHED - HIGH STRENGTH	6-3255	6-3263	411.50

**ACCESSORY KITS - (NOT INCLUDED IN THE ENGINE KIT)**

**BELLHOUSING KITS**

SIX POINT - HIGH STRENGTH	# 6-3091	\$ 58.50
TWELVE POINT - HIGH STRENGTH	6-3218	59.50

**ENGINE MOUNT KITS - FRONT CORNER**

TYPE MOUNTS WITH 7/16" BOLTS		
SIX POINT - HIGH STRENGTH	6-3032	60.50
TWELVE POINT - HIGH STRENGTH	6-3219	64.00

**ENGINE MOUNTS - CENTER OF BLOCK TYPE**

MOUNTS WITH 3/8" BOLTS		
SIX POINT - HIGH STRENGTH	6-3832	33.50
TWELVE POINT - HIGH STRENGTH	6-3833	35.00

**FAN PULLEY KITS**

SIX POINT - HIGH STRENGTH	6-3030	18.50
TWELVE POINT - HIGH STRENGTH	6-3031	19.50

**CARB MOUNT KITS -SEE PAGE 7**

**CRANK PULLEY KITS**

SIX POINT - HIGH STRENGTH	# 6-3220	\$ 26.00
TWELVE POINT - HIGH STRENGTH	6-3221	27.50

**EXHAUST BOLT KITS**

-SEE 12 COUNT 5/16" BOLT KITS ON PAGES 6 & 7

**STARTER KITS**

HEX HEAD	6-3034	6.00
SOCKET HEAD	6-3035	8.00
SIX POINT - HIGH STRENGTH	6-3244	20.50
TWELVE POINT - HIGH STRENGTH	6-3245	22.00

**FUEL INJECTOR KIT - BOTTOM PLATE WITH**

WEDGE LOCK WASHERS	6-3834	55.00
--------------------	--------	-------

**ENGINE  
KITS FOR  
BIG BLOCK  
MOPAR**  
383-413-426-440

CHRYSLER/DODGE  
PLYMOUTH

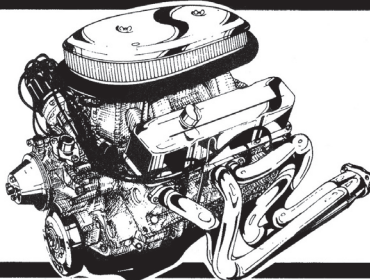

# KITS FOR BIG BLOCK MOPAR

**383 - 413 - 426 - 440**

Each engine kit includes component kits for the Distributor, Fuel Pump, Intake, Oil Pan, Thermostat, Timing Cover, Valley Cover, Valve Covers, and Water Pump.

\* NOTE INDENTED HEX, SIX POINT & TWELVE POINT BOLTS ARE MADE IN USA \*

FOR ENGINES WITH  
CAST VALVE COVERS

FOR ENGINES WITH SHEET  
METAL VALVE COVERS

PRICE:

	FOR ENGINES WITH CAST VALVE COVERS	FOR ENGINES WITH SHEET METAL VALVE COVERS	PRICE:
BUTTON & SOCKET HEAD	# 6-3140	# 6-3050	\$ 62.00
HEX/INDENTED HEX - ORIGINAL STYLE	6-3146	6-3142	122.00
SOCKET HEAD	6-3134	6-3052	75.50
SIX POINT - POLISHED - HIGH STRENGTH	6-3339	6-3138	361.00
TWELVE POINT - POLISHED - HIGH STRENGTH	6-3123	6-3139	387.50

**ACCESSORY KITS - (NOT INCLUDED IN THE ENGINE KIT)**

**BELLHOUSING KITS**

SIX POINT - HIGH STRENGTH	# 6-3093	\$ 44.00
TWELVE POINT - HIGH STRENGTH	6-3137	46.50

**CARB MOUNT KITS -SEE PAGE 7**

**CRANK PULLEY KITS**

SIX POINT - HIGH STRENGTH	6-3229	26.00
TWELVE POINT - HIGH STRENGTH	6-3230	27.50

**FAN PULLEY KITS**

SIX POINT - HIGH STRENGTH	6-3030	18.50
TWELVE POINT - HIGH STRENGTH	6-3031	19.50

**ENGINE MOUNT KITS - FOR 'B' BODY CARS:**

SIX POINT - HIGH STRENGTH	# 6-3148	\$ 83.50
TWELVE POINT - HIGH STRENGTH	6-3149	85.50

**EXHAUST BOLT KITS**

-SEE 12 COUNT 3/8" BOLT KITS ON PAGES 6 & 7

**STARTER KITS**

HEX HEAD	6-3081	6.00
SOCKET HEAD	6-3082	8.00
SIX POINT - HIGH STRENGTH	6-3244	20.50
TWELVE POINT - HIGH STRENGTH	6-3245	22.00



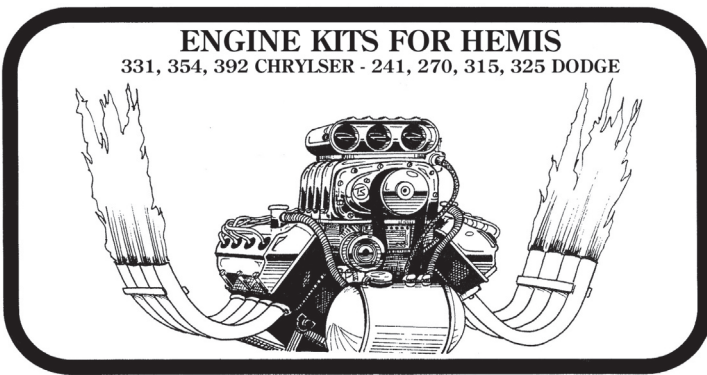

## ENGINE KITS FOR HEMIS

331, 354, 392 CHRYSLER - 241, 270, 315, 325 DODGE

# ENGINE KITS FOR <sup>27</sup>

## EARLY HEMI

**331 - 354 - 392 CHRYSLER  
241 - 270 - 315 - 325 DODGE**

Each engine kit includes component kits for the Cross Log-Water Manifold, Distributor, Fuel Pump, Intake, Oil Pan, Thermostat, Timing Cover, Valley Cover, Valve Covers, and Water Pump.

\* NOTE INDENTED HEX, SIX POINT & TWELVE POINT BOLTS ARE MADE IN USA \*

FOR ENGINES WITH CAST VALVE COVERS

FOR ENGINES WITH SHEET METAL VALVE COVERS

PRICE:

### 331/354/392 WITH CAST IRON INTAKES - WITH SINGLE 4 BARREL

BUTTON & SOCKET HEAD	# 6-3290	\$ 99.00
INDENTED HEX/HEX HEAD - ORIGINAL STYLE with Valve Cover Studs	6-3292	208.00
SOCKET HEAD	6-3293	107.00
SIX POINT - POLISHED - HIGH STRENGTH	6-3294	481.00
TWELVE POINT - POLISHED - HIGH STRENGTH	6-3295	512.50

### 331/354/392 WITH ALUMINUM INTAKES (2 1/4" LONG BOLTS)

BUTTON HEAD	# 6-3342	6-3296	94.50
HEX HEAD	6-3343	6-3297	88.75
SOCKET HEAD	6-3344	6-3299	105.50
SIX POINT - POLISHED - HIGH STRENGTH	6-3345	6-3340	479.00
TWELVE POINT - POLISHED - HIGH STRENGTH	6-3346	6-3341	505.00

### 241/270 DODGE WITH ALUMINUM INTAKES (1 1/2" LONG BOLTS)

BUTTON & SOCKET HEAD	6-3285	88.00
HEX HEAD	6-3286	88.00
SOCKET HEAD	6-3287	97.00
SIX POINT - POLISHED - HIGH STRENGTH	6-3288	467.00
TWELVE POINT - POLISHED - HIGH STRENGTH	6-3289	484.00

### 315/325 DODGE WITH ALUMINUM INTAKES (2" LONG BOLTS)

BUTTON & SOCKET HEAD	6-3265	94.00
HEX HEAD	6-3266	88.00
SOCKET HEAD	6-3267	106.00
SIX POINT - POLISHED - HIGH STRENGTH	6-3268	470.00
TWELVE POINT - POLISHED - HIGH STRENGTH	6-3269	499.00

## ACCESSORY KITS (NOT INCLUDED IN THE ENGINE KIT)

### ENGINE MOUNT KITS

SIX POINT - HIGH STRENGTH	# 6-3397	\$ 35.50
TWELVE POINT - HIGH STRENGTH	6-3398	37.50

### EXHAUST BOLT KITS

-SEE 14 COUNT BOLT KITS ON PAGES 6 & 7

### HARMONIC BALANCER KIT - WITH H.D. WASHER

SIX POINT - HIGH STRENGTH	# 6-3264	\$ 97.50
---------------------------	----------	----------

### HARMONIC BALANCER KIT FOR BIG BLOCK

(383-440) MOPAR & 426 HEMI:

SIX POINT - HIGH STRENGTH	6-3325	95.50
---------------------------	--------	-------



Early hemi rail at the York US-30 strip



This was my first car - bought it for \$35 off of this guy's grandson back in 1971. I later traded it for a box of tools, but that's another story. If I still had it, I would have to stuff an early hemi into it!

**T.O.T.A.L.L.Y.  
STAINLESS**

TOLL FREE ORDER LINE : 1-800-767-4781

## KITS FOR 426 HEMI ENGINES

**ENGINE KITS-** Every engine kit includes component kits for the Distributor, Fuel Pump, Intake, Oil Pan, Thermostat, Timing Cover, Valve Covers, and Water Pump.

* NOTE INDENTED HEX, SIX POINT & TWELVE POINT BOLTS ARE MADE IN USA *	FOR ENGINES WITH CAST VALVE COVERS	FOR ENGINES WITH SHEET METAL VALVE COVERS	PRICE:
BUTTON & SOCKET HEAD	# 6-3326	# 6-3327	\$ 62.50
INDENTED HEX/HEX HEAD - ORIGINAL STYLE	6-3331	6-3300	90.00
SOCKET HEAD	6-3332	6-3302	67.00
SIX POINT - POLISHED - HIGH STRENGTH	6-3333	6-3303	334.50
TWELVE POINT - POLISHED - HIGH STRENGTH	6-3334	6-3304	362.50

### ACCESSORY KITS (NOT INCLUDED IN THE ENGINE KIT)

#### BELLOUSING KITS

SIX POINT - HIGH STRENGTH	# 6-3321	\$ 51.50
TWELVE POINT - HIGH STRENGTH	6-3324	54.00

#### EXHAUST BOLT KITS - SEE PAGES 6 & 7

#### CARB MOUNT KITS - SEE PAGE 7

#### ENGINE MOUNT KITS

SIX POINT - HIGH STRENGTH	# 6-3322	\$ 34.00
TWELVE POINT - HIGH STRENGTH	6-3323	35.50

## KITS FOR LATE MODEL HEMI ENGINES

#### BELLOUSING KITS

SIX POINT - HIGH STRENGTH	# 5-5750	\$ 43.75
TWELVE POINT - HIGH STRENGTH	5-5751	45.00

#### EXHAUST BOLT KITS

-SEE 17 COUNT 3/8" BOLT KITS ON PAGES 6 & 7

#### AC/ALTERNATOR/POWER STEERING KITS

SOCKET HEAD	# 5-5717	\$ 29.75
SIX POINT - HIGH STRENGTH	5-5718	127.00
TWELVE POINT - HIGH STRENGTH	5-5719	134.00

## KITS FOR SLANT 6 ENGINES

Each engine kit includes component kits for the Distributor, Fuel Pump, Intake to Exhaust, Intake & Exhaust to Heads, Oil Filter, Oil Pan, Thermostat, Timing Cover, Valve Cover, and Water Pump.

* NOTE INDENTED HEX, SIX POINT & TWELVE POINT BOLTS ARE MADE IN USA *	FOR ENGINES WITH CAST VALVE COVERS	FOR ENGINES WITH SHEET METAL VALVE COVERS	PRICE:
BUTTON HEAD	# 6-3600	# 6-3665	\$ 78.50
INDENTED HEX/HEX HEAD - STOCK SYLE		6-3602	121.00
SOCKET HEAD	6-3603	6-3667	89.00
SIX POINT - POLISHED - HIGH STRENGTH	6-3604	6-3668	399.00
TWELVE POINT - POLISHED - HIGH STRENGTH	6-3605	6-3669	425.50

### ACCESSORY KITS (NOT INCLUDED IN THE ENGINE KIT)

#### BELLOUSING KITS

SIX POINT - HIGH STRENGTH	# 6-3321	\$ 51.50
TWELVE POINT - HIGH STRENGTH	6-3324	54.00

#### STARTER KITS

HEX HEAD	6-3081	6.00
SIX POINT - HIGH STRENGTH	6-3244	20.50
TWELVE POINT - HIGH STRENGTH	6-3245	22.00

#### FAN PULLEY KITS

SIX POINT - HIGH STRENGTH	6-3030	18.50
TWELVE POINT - HIGH STRENGTH	6-3031	19.50

## KITS FOR PONTIAC OVERHEAD CAM 6 CYL

Each engine kit includes component kits for the Distributor, Fuel Pump, Intake (1 barrel intake kit contains heavy washers & six point bolts), Oil Filter, Oil Pan, Thermostat, Timing Cover, Valve Covers, & Water Pump.

BUTTON HEAD & SIX POINT	6-6440	\$225.00
INDENTED HEX & HEX HEAD - ORIGINAL STYLE & SIX POINT	6-6441	299.00
SOCKET HEAD & SIX POINT	6-6442	227.00
SIX POINT - POLISHED - HIGH STRENGTH	6-6443	499.00
TWELVE POINT - POLISHED - HIGH STRENGTH	6-6444	536.50

### ACCESSORY KITS (NOT INCLUDED IN THE ENGINE KIT)

#### FAN PULLEY KITS - 3/4" LONG BOLTS

-STEEL PULLEYS WITHOUT A SPACER:		
SIX POINT - HIGH STRENGTH	6-5609	19.50
TWELVE POINT - HIGH STRENGTH	6-5607	20.50

#### BELLOUSING KITS - SEE PAGE 29

#### CARB MOUNT KITS - SEE PAGE 7

# TRANSMISSION KITS

## Automatic and Manual

GM - FORD - MOPAR

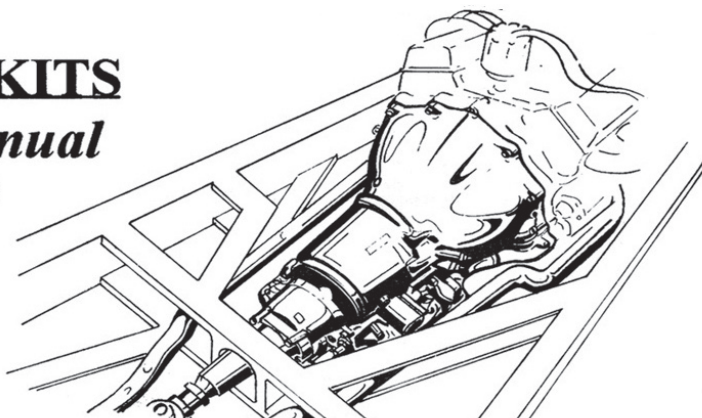

### BASE KITS FOR GM HYDROMATICS

-INCLUDES BOLTS & WASHERS FOR: BELL HOUSING, DUST COVER, VACUUM MODULATOR, SHIFT LEVER, SIDE COVER (400), TAIL SHIFT, & SPEEDOMETER HOUSING \*ORDER PAN KIT SEPARATELY\*

#### -POWERGLIDE

BUTTON & SIX POINT	# 6-6900	\$ 99.00
HEX & SIX POINT	6-6901	100.00
SOCKET & SIX POINT	6-6902	99.50
SIX POINT - HIGH STRENGTH	6-6903	112.00
TWELVE POINT - HIGH STRENGTH	6-6904	120.50

#### -350 TURBO - ALL BOLTS ARE US THREAD

BUTTON & SIX POINT	6-6905	78.50
HEX & SIX POINT	6-6906	80.00
SOCKET & SIX POINT	6-6907	80.50
SIX POINT - HIGH STRENGTH	6-6908	99.50
TWELVE POINT - HIGH STRENGTH	6-6909	104.50

#### -350 TURBO - BOLTS ARE METRIC & US

BUTTON & SOCKET	6-6910	62.00
HEX HEAD	6-6911	63.00
SOCKET HEAD	6-6925	63.00
SIX POINT - HIGH STRENGTH	6-6923	101.50
TWELVE POINT - HIGH STRENGTH	6-6924	107.50

#### -400 TURBO

BUTTON & SIX POINT	6-6913	102.00
HEX & SIX POINT	6-6914	108.00
SOCKET & SIX POINT	6-6915	108.50
SIX POINT - HIGH STRENGTH	6-6916	126.00
TWELVE POINT - HIGH STRENGTH	6-6917	132.00

#### -700 R-4 WITH US THREAD BELL HOUSING BOLTS AND 6MM DUST COVER BOLTS

BUTTON HEAD	6-6918	62.25
HEX HEAD	6-6919	59.50
SOCKET HEAD	6-6920	73.75
SIX POINT - HIGH STRENGTH	6-6921	127.00
TWELVE POINT - HIGH STRENGTH	6-6922	136.50

#### -700 R-4/4L60 - WITH US THREAD BELL HOUSING BOLTS AND 10MM DUST COVER BOLTS

BUTTON HEAD	5-1725	65.75
HEX HEAD	5-1726	61.25
SOCKET HEAD	5-1727	64.75
SIX POINT - HIGH STRENGTH	5-1728	134.50
TWELVE POINT - HIGH STRENGTH	5-1729	143.50

#### -4L80 - WITH US THREAD BELL HOUSING BOLTS

BUTTON HEAD	5-1715	60.75
HEX HEAD	5-1716	62.75
SOCKET HEAD	5-1717	63.00
SIX POINT - HIGH STRENGTH	5-1718	159.50
TWELVE POINT - HIGH STRENGTH	5-1719	168.00

#### -4L80 - ALL METRIC

BUTTON HEAD	5-1720	58.00
HEX HEAD	5-1721	55.50
SOCKET HEAD	5-1722	61.00
SIX POINT - HIGH STRENGTH	5-1723	175.00
TWELVE POINT - HIGH STRENGTH	5-1724	182.50

### BELL HOUSING KITS FOR GM

#### -1 1/4" LONG (US) FOR CAST IRON BELL HOUSINGS

SIX POINT - HIGH STRENGTH	# 6-5145	\$ 33.00
TWELVE POINT - HIGH STRENGTH	6-5146	35.00

#### -1 1/2" LONG (US) FOR ALUMINUM BELL HOUSINGS INCLUDED IN BASE TRANSMISSION KITS

SIX POINT - HIGH STRENGTH	6-5180	47.00
TWELVE POINT - HIGH STRENGTH	6-5181	49.00

#### - METRIC 5 BOLT TYPE (LS ENGINES):

SIX POINT - HIGH STRENGTH	5-1574	51.50
TWELVE POINT - HIGH STRENGTH	5-1575	52.50

#### - METRIC 7 BOLT TYPE (LS ENGINES):

SIX POINT - HIGH STRENGTH	5-1582	71.50
TWELVE POINT - HIGH STRENGTH	5-1583	75.50

#### - METRIC 8 BOLT TYPE (LS ENGINES):

SIX POINT - HIGH STRENGTH	5-1598	82.00
TWELVE POINT - HIGH STRENGTH	5-1599	85.50

### PAN KITS FOR HYDROMATICS

- NOT INCLUDED IN BASE TRANSMISSION KITS -

#### -P-GLIDE & 350-400 CAST ALUMINUM PANS

BUTTON HEAD	6-5503	9.00
HEX HEAD	6-5504	10.00
SOCKET HEAD	6-5505	10.25
SIX POINT - HIGH STRENGTH	6-5526	57.50
TWELVE POINT - HIGH STRENGTH	6-5527	61.00

#### -P-GLIDE & 350-400 SHEET METAL -STOCK OR CHROME

BUTTON HEAD	6-5506	8.50
HEX HEAD	6-5507	9.75
INDENTED HEX	6-5546	19.50
SOCKET HEAD	6-5508	10.00
SIX POINT - HIGH STRENGTH	6-5528	52.50
TWELVE POINT - HIGH STRENGTH	6-5529	55.00

#### -4L60/4L65/700 R-4 CAST ALUMINIUM PAN

BUTTON HEAD	6-5556	10.50
HEX HEAD	6-5557	10.50
SOCKET HEAD	6-5588	11.00
SIX POINT - HIGH STRENGTH	6-5589	90.50
TWELVE POINT - HIGH STRENGTH	6-5590	97.00

#### -4L60/4L65/700 R-4 SHEET METAL - STOCK OR CHROME

BUTTON HEAD	6-5553	10.00
HEX HEAD	6-5554	10.50
SOCKET HEAD	6-5555	10.75
SIX POINT - HIGH STRENGTH	6-5591	87.50
TWELVE POINT - HIGH STRENGTH	6-5592	93.50

#### -4L80 CAST ALUMINIUM PAN

BUTTON HEAD	5-1705	14.00
HEX HEAD	5-1706	13.50
SOCKET HEAD	5-1707	14.50
SIX POINT - HIGH STRENGTH	5-1708	107.50
TWELVE POINT - HIGH STRENGTH	5-1709	111.50

#### -4L80 SHEET METAL - STOCK OR CHROME

BUTTON HEAD	5-1710	11.00
HEX HEAD	5-1711	11.25
SOCKET HEAD	5-1712	13.50
SIX POINT - HIGH STRENGTH	5-1713	95.50
TWELVE POINT - HIGH STRENGTH	5-1714	99.50

SEE NEXT PAGE FOR KITS FOR FORD & MOPAR



## TRANSMISSION KITS (CONTINUED)

### BASE KITS FOR AOD, C-4/6 TRANSMISSIONS

**AOD:** INCLUDES BOLTS & WASHERS FOR: DUST COVER, REAR MOUNT, TAIL SHAFT, LINKAGE MOUNT, & SHIFTER ELECTRONICS. \*ORDER BELL HOUSING & PAN KITS SEPARATELY\*

BUTTON & SIX POINT	# 5-4500	\$ 60.50
HEX & SIX POINT	5-4501	61.50
SOCKET & SIX POINT	5-4502	63.50
SIX POINT - HIGH STRENGTH	5-4503	106.50
TWELVE POINT - HIGH STRENGTH	5-4504	114.00

**C4:** INCLUDES BOLTS & WASHERS FOR: DUST COVER, TRANSMISSION TO BELLHOUSING, REAR MOUNT, TAIL SHAFT, & SPEEDO CABLE. \*ORDER PAN & BELLHOUSING KITS SEPARATELY\*

BUTTON & SIX POINT	6-2900	80.50
HEX & SIX POINT	6-2901	82.50
SOCKET & SIX POINT	6-2902	84.00
SIX POINT - HIGH STRENGTH	6-2903	97.50
TWELVE POINT - HIGH STRENGTH	6-2904	99.50

**C6:** INCLUDES BOLTS & WASHERS FOR: DUST COVER, NEUTRAL SHIFT, REAR MOUNT, SIDE PLATE, TAIL SHAFT, & SPEEDOMETER HOUSING. \*ORDER BELLHOUSING & PAN KITS SEPARATELY\*

BUTTON & SIX POINT	6-0914	74.00
HEX & SIX POINT	6-0915	75.00
SOCKET & SIX POINT	6-0916	76.50
SIX POINT - HIGH STRENGTH	6-0943	116.00
TWELVE POINT - HIGH STRENGTH	6-0944	122.50

### PAN KITS FOR AOD, C-4 & C-6

#### --AOD CAST ALUMINIUM PANS

BUTTON HEAD	5-4512	10.50
HEX HEAD	5-4513	10.50
SOCKET HEAD	5-4514	10.50
SIX POINT - HIGH STRENGTH	5-4515	78.50
TWELVE POINT - HIGH STRENGTH	5-4516	84.00

#### -AOD SHEET METAL- STOCK OR CHROME PANS

BUTTON HEAD	5-4506	10.25
HEX HEAD	5-4507	10.00
SOCKET HEAD	5-4509	10.50
SIX POINT - HIGH STRENGTH	5-4510	76.50
TWELVE POINT - HIGH STRENGTH	5-4511	82.50

#### -C-4 CAST ALUMINIUM PANS

BUTTON HEAD	6-0900	8.50
HEX HEAD	6-0901	9.50
SOCKET HEAD	6-0902	9.75
SIX POINT - HIGH STRENGTH	6-0917	47.50
TWELVE POINT - HIGH STRENGTH	6-0918	50.50

#### -C-4 SHEET METAL- STOCK OR CHROME PANS

BUTTON HEAD	6-0903	8.50
HEX HEAD	6-0904	9.00
INDENTED HEX HEAD	6-0928	11.00
SOCKET HEAD	6-0905	9.50
SIX POINT - HIGH STRENGTH	6-0919	46.00
TWELVE POINT - HIGH STRENGTH	6-0920	51.00

#### -C-6 CAST ALUMINIUM PANS

BUTTON HEAD	6-0906	11.50
HEX HEAD	6-0907	13.00
SOCKET HEAD	6-0908	13.25
SIX POINT - HIGH STRENGTH	6-0921	74.00
TWELVE POINT - HIGH STRENGTH	6-0922	78.50

#### -C-6 SHEET METAL - STOCK OR CHROME PANS

BUTTON HEAD	6-0909	11.00
HEX HEAD	6-0910	12.50
SOCKET HEAD	6-0911	12.75
SIX POINT - HIGH STRENGTH	6-0923	69.50
TWELVE POINT - HIGH STRENGTH	6-0924	76.50

### BELLHOUSING KITS FOR FORDS C4/6

- SEE THE ACCESSORY SECTIONS FOR FORD ENGINE: PAGES 13-14



### BASE KITS FOR 727 TORQUEFLITE

-INCLUDES FASTENERS FOR: DUST COVER TAIL SHIFT, & SPEEDOMETER CLAMP. \* ORDER BELLHOUSING & PAN KITS SEPARATELY\*

BUTTON HEAD	# 6-3100	\$ 41.00
HEX HEAD	6-3101	42.00
SOCKET HEAD	6-3102	43.00
SIX POINT - HIGH STRENGTH	6-3127	66.00
TWELVE POINT - HIGH STRENGTH	6-3128	70.50

### BELLHOUSING KITS FOR TORQUEFLITES

-REFER TO INDEX FOR SPECIFIC ENGINE APPLICATION. BELLHOUSING KITS ARE LISTED WITH THE ACCESSORY KITS AT THE END OF EACH ENGINE SECTION

### PAN KITS FOR 727 & 904

#### -CAST ALUMINIUM PANS

BUTTON HEAD	# 6-3103	\$ 10.00
HEX HEAD	6-3104	11.25
SOCKET HEAD	6-3105	11.50
SIX POINT - HIGH STRENGTH	6-3129	58.50
TWELVE POINT - HIGH STRENGTH	6-3130	61.50

#### -SHEET METAL -STOCK OR CHROME PAN

BUTTON HEAD	6-3106	9.75
HEX HEAD	6-3107	10.75
INDENTED HEX- ORIGINAL STYLE	6-3133	12.00
SOCKET HEAD	6-3108	11.50
SIX POINT - HIGH STRENGTH	6-3131	60.00
TWELVE POINT - HIGH STRENGTH	6-3132	63.50

### MANUAL TRANSMISSION KITS

#### -KIT FOR BORG-WARNER T-10 SIDE COVER

BUTTON HEAD	# 6-5560	\$ 7.00
HEX HEAD	6-5561	7.50
SOCKET HEAD	6-5562	7.75
SIX POINT - HIGH STRENGTH	6-5563	40.00
TWELVE POINT - HIGH STRENGTH	6-5564	42.00

#### -KIT FOR MUNCIE SIDE COVER

BUTTON HEAD	6-5565	6.00
HEX HEAD	6-5566	6.50
SOCKET HEAD	6-5567	6.75
SIX POINT - HIGH STRENGTH	6-5568	36.00
TWELVE POINT - HIGH STRENGTH	6-5569	40.50

#### - KIT FOR TREMEC TKO 5 SPEED: 74 pc kits

BUTTON HEAD	5-4800	102.75
HEX HEAD	5-4801	103.00
SOCKET HEAD	5-4802	104.00
SIX POINT - HIGH STRENGTH	5-4803	224.50
TWELVE POINT - HIGH STRENGTH	5-4804	230.00

#### - KIT FOR TREMEC T56 6 SPEED:

US THREADS:

SIX POINT - HIGH STRENGTH	5-4858	213.50
TWELVE POINT - HIGH STRENGTH	5-4859	219.50

#### METRIC THREADS:

SIX POINT - HIGH STRENGTH	5-4860	213.00
TWELVE POINT - HIGH STRENGTH	5-4861	219.00

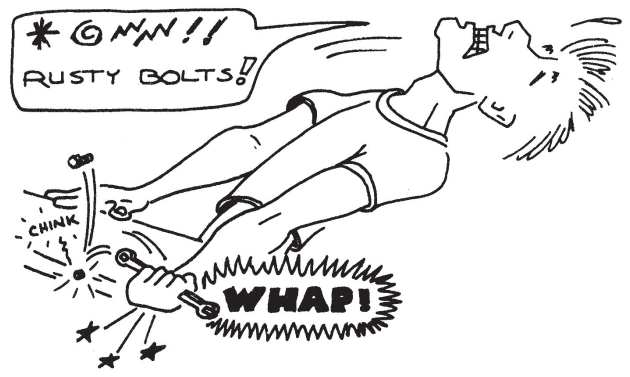



## OIL PAN & REAR END PLUGS



**WE MAKE THESE IN OUR SHOP FROM STAINLESS BAR STOCK - THEY LOOK GREAT AND THE BUTTON HEAD PLUGS ARE LOW PROFILE SO YOU WON'T SNAG A PLUG!**

FOR STANDARD PIPE PLUGS SEE PAGE 146

### OIL PAN PLUGS: SUPER LOW PROFILE!

1/2-20 TRUSS SOCKET HEAD (3/4" OD FLANGE)	# 7-0402	\$ 23.50
12-1.0 MM TRUSS SOCKET HEAD	1-6008	25.50
12MM PLUGS FOR CHEVY LS ENGINES - SEE PAGE 20		

### PLUGS FOR DIFFERENTIALS:

<b>5/8-18: (1" OD FLANGE) (FOR SOME 9" FORD DIFFERENTIALS)</b>		
BUTTON HEAD	7-0403	27.50
SQUARE FLANGE HEAD	7-0404	37.50
<b>3/4-16: (1 1/8" OD FLANGE) (FOR SOME 9" FORD DIFFERENTIALS)</b>		
BUTTON HEAD	7-0405	30.50
SQUARE FLANGE HEAD	7-0406	45.50
<b>7/8-18 (1 " OD FLANGE)</b>		
BUTTON HEAD	7-0414	27.50
<b>1-20 (1 3/8" OD FLANGE) FOR 1950'S GM CARS &amp; TRUCKS</b>		
BUTTON HEAD	7-0401	39.50
SQUARE FLANGE HEAD - ORIGINAL STYLE	7-0400	52.50
<b>16-1.5 MM PLUG</b>		
BUTTON HEAD (1" OD FLANGE)	7-0413	27.50
<b>22.5 MM PLUGS FOR GM 4X4 TRANSFER CASES</b>		
BUTTON HEAD (1 1/4" OD FLANGE)	7-0407	35.00
<b>1/2" STRAIGHT PIPE THREAD (1 1/4" OD FLANGE) (FOR '56-'66 BOP)</b>		
BUTTON HEAD	7-0409	39.50
SQUARE FLANGE HEAD - ORIGINAL STYLE	7-0410	50.50

## REAR END COVER KITS

FOR GM - DANA

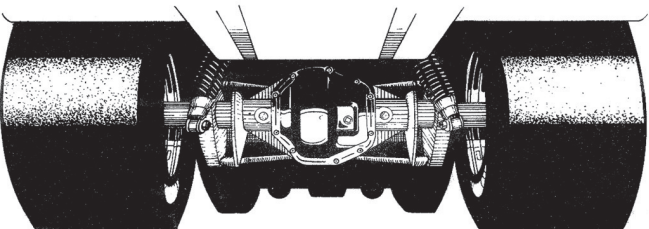

(AMC 20 HAS SAME BOLTS AS GM 12 BOLTS)

### REAR COVER KITS FOR GM

<b>-10 BOLT REAR COVER KITS-CAST ALUMINIUM</b>		
BUTTON HEAD	6-5509	8.00
HEX HEAD	6-5510	9.00
SOCKET HEAD	6-5511	9.50
SIX POINT - HIGH STRENGTH	6-5532	47.50
TWELVE POINT - HIGH STRENGTH	6-5533	50.00
<b>-10 BOLT REAR COVER KITS-SHEET METAL (STOCK, CHROMED, OR ANODIZED)</b>		
BUTTON HEAD	6-5512	7.75
HEX HEAD	6-5513	8.50
INDENTED HEX- ORIGINAL STYLE	6-5537	16.00
SOCKET HEAD	6-5514	9.00
SIX POINT - HIGH STRENGTH	6-5535	44.00
TWELVE POINT - HIGH STRENGTH	6-5536	46.50
<b>-12 BOLT REAR COVER KITS-CAST ALUMINIUM</b>		
BUTTON HEAD	6-5515	9.00
HEX HEAD	6-5516	10.00
SOCKET HEAD	6-5517	10.50
SIX POINT - HIGH STRENGTH	6-5545	56.50
TWELVE POINT - HIGH STRENGTH	6-5538	59.00
<b>-12 BOLT REAR COVER KITS-SHEET METAL (STOCK, CHROMED, OR ANODIZED)</b>		
BUTTON HEAD	6-5518	8.75
HEX HEAD	6-5519	9.50
INDENTED HEX- ORIGINAL STYLE	6-5541	20.00
SOCKET HEAD	6-5549	10.50
SIX POINT - HIGH STRENGTH	6-5539	51.00
TWELVE POINT - HIGH STRENGTH	6-5540	55.50

### REAR COVER KITS FOR DANA

<b>-DANA 30/44 REAR COVER KITS-SHEET METAL (STOCK, CHROMED, OR ANODIZED) 5/16-18 BOLTS</b>		
BUTTON HEAD	6-3109	7.00
HEX HEAD	6-3110	7.75
INDENTED HEX-ORIGINAL STYLE	6-3120	12.00
SOCKET HEAD	6-3111	8.50
SIX POINT - HIGH STRENGTH	6-3118	45.50
TWELVE POINT - HIGH STRENGTH	6-3119	47.50
<b>-DANA 60 REAR COVER KITS-CAST ALUMINIUM -3/8-16 BOLTS</b>		
BUTTON HEAD	6-3112	10.00
HEX HEAD	6-3113	11.00
INDENTED HEX-ORIGINAL STYLE	6-3189	15.00
SOCKET HEAD	6-3114	12.25
SIX POINT - HIGH STRENGTH	6-3121	50.00
TWELVE POINT - HIGH STRENGTH	6-3122	53.50
<b>-DANA 60 REAR COVER KITS-SHEET METAL</b>		
BUTTON HEAD	6-3115	9.00
HEX HEAD	6-3116	10.25
INDENTED HEX- ORIGINAL STYLE	6-3126	25.00
SOCKET HEAD	6-3117	11.25
SIX POINT - HIGH STRENGTH	6-3124	47.50
TWELVE POINT - HIGH STRENGTH	6-3125	51.50

### KITS FOR FORD 9" 'CHUNK' (GEAR SECTOR):

NYLON INSERT LOCK NUTS & WASHERS	6-3150	7.00
TALL ACORN NUTS & LOCK WASHERS	6-3151	32.00

# AFTERMARKET SUSPENSION KITS

**ALL SUSPENSION KITS USE US MADE HIGH STRENGTH SIX POINT BOLTS -**

**1/2" AND SMALLER SIZES ARE MADE BY ARP, THE LARGER SIZES WE HAVE CUSTOM MADE FROM HEAT TREATED 17-4 PH STAINLESS. WE HAVE U-BOLTS, TALL NUTS AND MANY OF THE WASHERS CUSTOM MADE.**

**KITS INCLUDE GREASE FITTINGS AND COTTER KEYS IF NEEDED, BUT NOT SLOTTED TALL (CASTLE) NUTS. THE HEIGHT OF CASTLE NUTS IS DETERMINED BY THE MANUFACTURER OF THE BALL JOINTS/TIE ROD ENDS. WE STOCK TALL CASTLE NUTS AND CUT THEM TO YOUR HEIGHT - TO ORDER. SEE PAGE 130.**

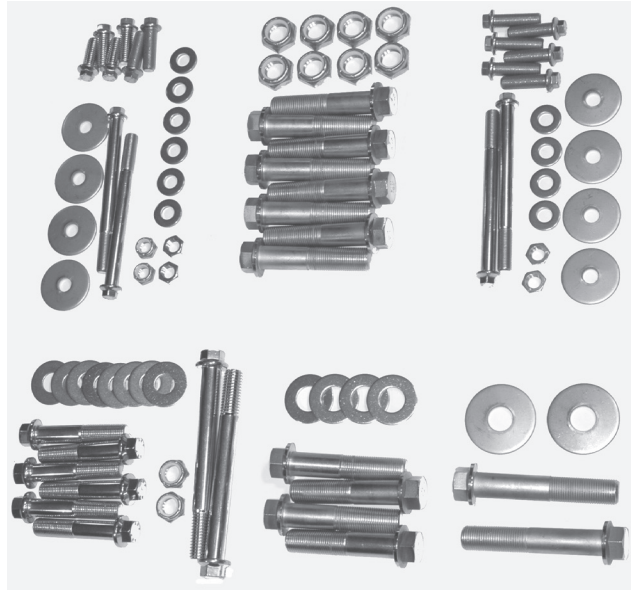

## AFTERMARKET SUSPENSION KITS FOR:

### **ART MORRISON TRI-5 FRONT & REAR SUSPENSION - SHOWN IN PICTURE ABOVE -**

SIX POINT - POLISHED

# 6-9100

\$ 837.25

### **DETROIT SPEED HYDROFORMED FRONT SUBFRAME SUSPENSION**

SIX POINT - POLISHED

6-9120

476.00

### **DETROIT SPEED QUADRALINK REAR SUSPENSION**

SIX POINT - POLISHED

6-9121

458.25

### **HEIDT'S SUSPENSION KITS - SIX POINT - POLISHED**

SUPERIDE FRONT SUSPENSION (REAR STEER)

6-9172

289.75

SUPERIDE II (FRONT STEER) W/O SWAY BAR

6-9173

353.75

SUPERIDE II (FRONT STEER) WITH SWAY BAR

6-9177

353.75

INDEPENDENT REAR SUSPENSION -STREET ROD

6-9175

740.25

'PRO-G' FRONT SUSPENSION - SIX POINT

6-2897

529.25

\* DOES NOT INCLUDE CASTLE NUTS \*

'PRO-G' INDEPENDENT REAR - SIX POINT

6-2899

840.75

'PRO-G' INDEPENDENT REAR - TWELVE POINT

6-2895

1885.00

'PRO-G' FRAME ADAPTERS TO CAMARO SUB-FRAME

6-2898

92.50

### **JIM MEYER RACING PRODUCTS - G4 FOR 1955-57 CHEVY**

FRONT SUSPENSION - SIX POINT - POLISHED

6-9161

707.00

REAR SUSPENSION - SIX POINT - POLISHED

6-9166

538.50

### **G3 FOR 62-72 CHEVY TRUCK**

FRONT SUSPENSION - SIX POINT - POLISHED

6-9160

292.25

REAR LADDER BAR SUSPENSION - SIX PT - POLISHED

6-9165

485.50

### **MARTZ - A-BODY TUBE CHASSIS (FRONT & REAR SUSPENSION)**

SIX POINT - POLISHED

6-9194

977.50

### **1934 OUTLAW CHASSIS KIT (FRONT & REAR SUSPENSION)**

SIX POINT - POLISHED

6-9180

556.50

### **OZE SUSPENSION WITH AIR BAGS**

SIX POINT - POLISHED

6-9190

874.00

# AFTERMARKET SUSPENSION KITS

ALL SUSPENSION KITS USE US MADE HIGH STRENGTH BOLTS -

## PETE & JAKE'S SUSPENSION KITS:

FOR FRONT SUSPENSION WITH TRANSVERSE SPRING & HAIR PIN RADIUS RODS:

SIX POINT - HIGH STRENGTH - POLISHED	# 6-9144	\$ 297.25
TWELVE POINT - HIGH STRENGTH - POLISHED	6-9145	302.25

FOR REAR SUSPENSION WITH TRANSVERSE SPRING & HAIR PIN LADDER BARS:

SIX POINT - HIGH STRENGTH - POLISHED	6-9146	310.50
TWELVE POINT - HIGH STRENGTH - POLISHED	6-9147	311.50

## PROGRESSIVE AUTOMOTIVE FRONT SUSPENSION

SIX POINT - POLISHED	6-9130	434.75
----------------------	--------	--------

## SCOTT'S SUSPENSION KITS - SIX POINT - POLISHED

FRONT STEER COIL OVER FRONT	6-9150	759.50
REAR STEER COIL OVER FRONT	6-9151	711.00
FRONT STEER AIR SHOCK FRONT	6-9152	725.00
REAR STEER AIR SHOCK FRONT	6-9153	674.50
COIL OVER REAR	6-9154	606.00
AIR SHOCK REAR	6-9155	608.00

**TCI CHASSIS KIT FOR 1940 FORD** - INCLUDES FRONT & REAR SUSPENSION, STEERING RACK, ENGINE MOUNTS, PROPORTIONING VALVE MOUNT, GREASE FITTINGS & COTTER PINS.

SIX POINT - POLISHED	6-4999	667.75
----------------------	--------	--------

**TOTALLY STAINLESS KITS FOR AFTERMARKET C-4 CHASSIS \* DOES NOT INCLUDE FRONT CALIPAR BOLTS**

FRONT SUSPENSION - SIX POINT - POLISHED	5-1900	916.00
---	--------	--------

# KITS FOR 1970-72 BUICK GS/SKYLARK

**BODY KITS**- Every Body Kit includes component kits for Bumpers & Brackets, Door Hinges, Door Latches & Strikers, Door Sills, Firewall, Front Body Mount (Core Support to Frame), Front Sheet Metal, Gas Tank, Glove Box, Headlight Mounting Screws, Hood Hinges, Hood Latch & Catch, Hood Assembly, Interior Trim Screws, Lens Screws, Radiator Support, Trunk Hinges, Trunk Latch & Catch, and Window Trim Screws.

Contains one of each component kit for:

BUTTON, FLAT SOCKET & SOCKET HEAD (CUSTOM STYLE)	# 6-2750	\$ 305.00
INDENTED HEX & PHILLIPS HEAD (OEM STYLE BOLTS)	6-2751	450.00
ORIGINAL STYLE - INDENTED HEX & PHILLIPS WITH BLACK STAINLESS (WHERE APPROPRIATE)	6-2752	490.00

## ACCESSORY KITS: (NOT INCLUDED IN THE BODY KIT)

**CHASSIS KIT** - INCLUDES FRONT & REAR SUSPENSION, SWAY BARS, STEERING BOX, ENGINE MOUNTS & TRANSMISSION CROSS MEMBER - HIGH STRENGTH - "CASTLE" NUTS NOT INCLUDED - SEE PAGE 130

SIX POINT - POLISHED	# 6-8162	\$ 747.00
TWELVE POINT - POLISHED	6-2749	779.50

**BODY MOUNT KITS** - SUPPLEMENT TO FRONT MOUNT: (12 BOLTS & WASHERS)

HEX HEAD	6-1951	64.00
SOCKET HEAD	6-1952	92.00
SIX POINT - POLISHED	6-1953	165.00
TWELVE POINT - POLISHED	6-1959	173.50

**DOOR STRIKERS KIT** - SOCKET HEAD SHOULDER BOLTS WITH WASHERS

	6-8154	59.95
--	--------	-------

**ENGINE KITS** -SEE PAGE 17

**ENGINE MOUNTS TO FRAME KITS**

SIX POINT - POLISHED	6-1945	45.50
TWELVE POINT - POLISHED	6-1946	49.50

**FRONT & REAR SUSPENSION KITS** - HIGH

STRENGTH STAINLESS BOLTS, WITH KNURLED BOLTS & TALL NUTS, COMPLETE WITH ZERKS & COTTERS,

\*\*CASTLE NUTS NOT INCLUDED - SEE PAGE 130\*

SIX POINT - POLISHED	6-8157	558.50
TWELVE POINT - POLISHED	6-2745	575.50

## REAR SHOCK MOUNT STUD KIT

17-4 PH - HIGH STRENGTH STUDS & NUTS # 6-8170 \$ 86.50

## REAR SWAY BAR KIT

SIX POINT - POLISHED	6-8185	51.50
TWELVE POINT - POLISHED	6-8186	53.50

**REAR COVER KITS** - SEE PAGE 31

## STEERING BOX COVER & MOUNT KITS

SIX POINT - POLISHED	6-1936	65.00
TWELVE POINT - POLISHED	6-1937	72.00

## TRANSMISSION CROSSMEMBER KITS

SIX POINT - POLISHED	6-1768	39.50
TWELVE POINT - POLISHED	6-1771	42.00

**TRANSMISSION KITS** -SEE PAGE 29-30

## WHEEL WELL MOULDING KIT

ORIGINAL STYLE - ROUND WASHER HEAD	6-1796	8.00
CUSTOM STYLE - BUTTON HEAD	6-1764	9.00

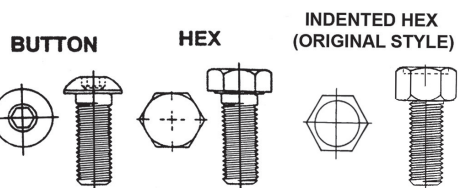

# BODY KITS FOR CADILLACS

## **BODY KITS FOR 1955 CADILLAC:**

- Every Body Kit includes component kits for Body Mounting, Bumpers & Brackets, Door Hinges, Door Jambs (Latches, Strikers & Door Sills), Firewall, Front Sheet Metal, Grill & Head lights, Hood Hinges, Hood Latch & Catch, Hood Moldings & Ornaments, Interior Trim Screws, Radiator Support & Horn, Rear panels & Quarter Molding Screws, Tail light Screws, Trunk Hinges, Trunk Latch & Catch, and Vent Window Screws.

## **KITS FOR CONVERTIBLES:**

CUSTOM STYLE - BUTTON & FLAT SOCKET HEAD	# 6-6649	\$ 682.75
ORIGINAL STYLE - INDENTED HEX, HEX & PHILLIPS HEAD - 1090 PIECES	6-6651	799.00

## **KITS FOR SEDANS:**

CUSTOM STYLE - BUTTON & FLAT SOCKET HEAD	6-6652	685.00
ORIGINAL STYLE - INDENTED HEX, HEX & PHILLIPS HEAD	6-6654	799.00

## **BODY KITS FOR: 1959-60 CADILLAC COUPE - 1398 PIECES!**

- Every Body Kit includes component kits for Antenna, Body Mounting, Bumpers & Brackets, Door Hinges, Door Latches & Strikers, Door Sills, Firewall, Front Sheet Metal, Grill, Glove Box, Headlights Mounting Screws, Hood Hinges, Hood Latch & Catch, Hood Assembly, Interior Trim Screws, Lens Screws, License Plate, Radiator Support, Trunk Hinges, Trunk Latch & Catch, and Window Trim Screws.

CUSTOM STYLE - BUTTON & FLAT SOCKET HEAD	# 6-6798	\$ 625.00
ORIGINAL STYLE - INDENTED HEX, HEX & PHILLIPS HEAD	6-6799	899.00

## **ACCESSORY KITS: (NOT INCLUDED IN THE BODY KIT)**

**ENGINE KITS -SEE PAGE 18**

# BODY KITS FOR 1940-54 CHEVROLET

**BODY KITS-** Every Body Kit includes component kits for Body Mounting Core Support (1949-54 ONLY), Bumpers & Brackets, Door Hinges, Door Latches & Strikers, Door Sills, Door Straps, Firewall, Front Sheet Metal, Glove Box, Headlight Mounting Screws, Hood Hinges, Hood Latch & Catch, Hood Assembly, Interior Trim Screws, Lens Screws, Radiator Support, Trunk Hinges, Trunk Latch & Catch, and Window Trim Screws.

## **1940 KIT**

BUTTON / FLAT SOCKET/ SOCKET HEAD - CUSTOM LOOK	# 9-1800	\$ 425.00
INDENTED HEX/ HEX/ PHILLIPS HEAD - ORIGINAL STYLE	9-1801	515.00

## **1941-48 KIT**

BUTTON / FLAT SOCKET / SOCKET HEAD - CUSTOM LOOK	6-8350	370.50
INDENTED HEX / HEX / PHILLIPS HEAD - ORIGINAL STYLE	6-8351	405.00

## **1949-50 KIT**

BUTTON / FLAT SOCKET / SOCKET HEAD - CUSTOM LOOK	6-8498	385.00
INDENTED HEX / HEX / PHILLIPS HEAD - ORIGINAL STYLE	6-8499	399.00

## **1951-52 KIT**

BUTTON / FLAT SOCKET / SOCKET HEAD - CUSTOM LOOK	6-8448	365.00
INDENTED HEX / HEX / PHILLIPS HEAD - ORIGINAL STYLE	6-8449	395.00

## **1953-1954 KIT - 891 PC**

BUTTON / FLAT SOCKET HEAD / SOCKET HEAD - CUSTOM LOOK	6-8450	365.75
INDENTED HEX / HEX / PHILLIPS HEAD - ORIGINAL STYLE	6-8451	390.00



## **ACCESSORY KITS (NOT INCLUDED IN THE BODY KIT)**

**ENGINE KITS - SEE PAGE 19-23**

## **GRILL ASSEMBLY - 1940**

BUTTON HEAD & NYLONS	# 9-1810	\$ 11.00
TRUSS HEAD & KEP NUTS	9-1811	10.00

## **HOOD HINGE SHOULDER BOLTS -**

SET OF (4) MADE IN OUR SHOP FROM 17-4 PH HIGH STRENGTH STAINLESS WITH WAVE WASHERS

### **1940:**

BUTTON HEAD	9-1824	80.00
HEX HEAD (ORIGINAL STYLE)	9-1825	81.75

### **1941-54:**

BUTTON HEAD	6-8398	82.00
HEX HEAD (ORIGINAL STYLE)	6-8399	83.50

**WE WERE INTO CARS EARLY - NOW IF WE LOWER IT A LITTLE, AND DROP IN A CADDY V8, DO YOU THINK DAD WILL NOTICE?**





## BODY & SUSPENSION KITS FOR 1955-57 CHEVROLET



Body Kits include component kits for Bumpers & Brackets, Door Hinges, Door Latches & Strikers, Door Sills, Filler Tube, Firewall, Front Sheet Metal, Gas Tank Mount, Glove Box, Headlight Mounting Screws, Hood Hinges, Hood Latch & Catch, 1957 Hood Assembly, Misc. Interior Trim Screws, Lens Screws, Radiator Support, Seat trim, Steering Box Cover & Column, Trunk Hinges, Trunk Latch & Catch, and Window Trim Screws.

\*\* NOTE: INDENTED HEX (ORIGINAL STYLE) BOLTS ARE MADE IN USA \*\*

### 1955 CONVERTIBLE KIT - 893 PIECES

BUTTON HEAD	# 6-1150	\$ 420.50
HEX HEAD	6-1076	410.75
INDENTED HEX	6-7911	485.00
ORIGINAL STYLE - INDENTED HEX WITH BLACK STAINLESS (WHERE APPROPRIATE)	6-1077	495.00

### 1955 HARDTOP KIT - 848 PIECES

BUTTON HEAD	6-1066	380.75
HEX HEAD	6-1067	365.75
INDENTED HEX	6-7910	435.00
ORIGINAL STYLE - INDENTED HEX WITH BLACK STAINLESS (WHERE APPROPRIATE)	6-1068	445.00

### 1955 NOMAD KIT - 1024 PIECES

BUTTON HEAD	6-7930	410.75
HEX HEAD	6-7931	399.00
INDENTED HEX	6-7932	485.00
ORIGINAL STYLE - INDENTED HEX WITH BLACK STAINLESS (WHERE APPROPRIATE)	6-7933	495.00

### 1955 SEDAN KIT- 843 PIECES

BUTTON HEAD	6-1063	385.75
HEX HEAD	6-1064	375.00
INDENTED HEX	6-7909	435.00
ORIGINAL STYLE - INDENTED HEX WITH BLACK STAINLESS (WHERE APPROPRIATE)	6-1065	445.00
SIX POINT -POLISHED	6-9611	999.00

### 1956 CONVERTIBLE KIT - 889 PIECES

BUTTON HEAD	6-1084	435.75
HEX HEAD	6-1085	425.50
INDENTED HEX	6-7914	495.00
ORIGINAL STYLE - INDENTED HEX WITH BLACK STAINLESS (WHERE APPROPRIATE)	6-1086	505.00

### 1956 HARDTOP KIT - 844 PIECES

BUTTON HEAD	6-1081	360.50
HEX HEAD	6-1082	355.00
INDENTED HEX	6-7913	445.00
ORIGINAL STYLE - INDENTED HEX WITH BLACK STAINLESS (WHERE APPROPRIATE)	6-1083	455.00

### 1956 NOMAD KIT - 990 PIECES

BUTTON HEAD	6-7934	410.00
HEX HEAD	6-7935	399.00
INDENTED HEX	6-7936	495.00
ORIGINAL STYLE - INDENTED HEX WITH BLACK STAINLESS (WHERE APPROPRIATE)	6-7937	515.00

### 1956 SEDAN KIT - 840 PIECES

BUTTON HEAD	6-1078	375.50
HEX HEAD	6-1079	350.00
INDENTED HEX	6-7912	489.00
ORIGINAL STYLE - INDENTED HEX WITH BLACK STAINLESS (WHERE APPROPRIATE)	6-1080	499.00

### 1957 CONVERTIBLE KIT- 971 PIECES

BUTTON HEAD	6-1093	475.00
HEX HEAD	6-1094	470.75
INDENTED HEX	6-7916	575.00
ORIGINAL STYLE - INDENTED HEX WITH BLACK STAINLESS (WHERE APPROPRIATE)	6-1095	595.50



Body kit shown for a 1955 hardtop

### 1957 HARDTOP KIT - 927 PIECES

BUTTON HEAD	# 6-1090	\$ 455.75
HEX HEAD	6-1091	445.50
INDENTED HEX	6-1054	535.00
ORIGINAL STYLE - INDENTED HEX WITH BLACK STAINLESS (WHERE APPROPRIATE)	6-1092	555.00

### 1957 NOMAD KIT - 1090 PIECES

BUTTON HEAD	6-7938	470.75
HEX HEAD	6-7939	455.75
INDENTED HEX	6-7940	565.00
ORIGINAL STYLE - INDENTED HEX WITH BLACK STAINLESS (WHERE APPROPRIATE)	6-7941	585.00

### 1957 SEDAN KIT - 900 PIECES

BUTTON HEAD	6-1087	455.75
HEX HEAD	6-1088	445.00
INDENTED HEX	6-7915	515.00
ORIGINAL STYLE - INDENTED HEX WITH BLACK STAINLESS (WHERE APPROPRIATE)	6-1089	525.00



Uncle Sam's '57 four door hardtop in 1967.

**-SEE NEXT PAGE FOR ACCESSORY KITS-**

## ACCESSORY KITS FOR 1955-57 CHEVY'S (NOT INCLUDED IN THE BODY KIT)

### CHASSIS KIT FOR 55-57 - INCLUDES FRONT & REAR SUSPENSION KITS, PLUS STEERING BOX KIT

SIX POINT - HIGH STRENGTH	# 6-7928	\$ 715.50
TWELVE POINT - HIGH STRENGTH	6-7950	720.00

### BODY MOUNT - WITH HEAVY DUTY WASHERS:

#### - HIGH STRENGTH - SIX POINT

SEDAN & WAGON	6-7925	150.00
HARDTOP	6-7926	196.00
CONVERTIBLE	6-7929	250.00

#### - HIGH STRENGTH - TWELVE POINT

SEDAN & WAGON	6-7954	155.00
HARDTOP	6-7955	205.00
CONVERTIBLE	6-7956	255.00

### BUMPERETTES KIT FOR '55's:

CARRIAGE HEAD	6-7957	45.00
---------------	--------	-------

### CONVERTIBLE TOP KIT - FITS 55-57 - 178PC

FOR ASSEMBLING & INSTALLING YOUR TOP		
BUTTON/FLAT SOCKET HEAD	6-7947	383.50
ORIGINAL STYLE	6-7948	399.00

### GUIDE PINS FOR TOPS:

ORIGINAL STYLE - POLISHED:

2-8100	\$ 18.00 EACH
6-7890	35.50 PER PAIR



### FRONT SUSPENSION BOLT KITS -158 PCS

IN HIGH STRENGTH BOLTS! INCLUDES GREASE ZERKS & COTTER PINS \*CASTLE NUTS NOT INCLUDED SEE PAGE 130

SIX POINT - HIGH STRENGTH	6-1098	428.00
TWELVE POINT - HIGH STRENGTH	6-1099	431.00

### REAR SUSPENSION BOLT KITS

-GRADE 8 STAINLESS! INCLUDES U-BOLTS AND TALL NUTS PLUS THE THROUGH BOLTS FOR THE SPRINGS AND HARDWARE FOR THE SHOCKS!

SIX POINT - HIGH STRENGTH	6-7922	269.00
TWELVE POINT - HIGH STRENGTH	6-7949	275.00

### STEERING BOX KIT - WITH HEAVY HEX NUTS

CARRIAGE HEAD - HIGH STRENGTH 17-4PH	6-1051	99.00
--------------------------------------	--------	-------

### ORIGINAL STYLE ENGINE KITS

-SEE THE STRAIGHT SIX CHEVY ENGINE KITS - PAGE 19

-SEE THE SMALL BLOCK CHEVY ENGINE KITS - PAGE 21

### HIDDEN DOOR HINGE BOLTS

HEX HEAD	6-1050	10.50
----------	--------	-------

### REAR DOOR KITS - 4 DOOR CARS

PHILLIPS HEAD	6-7942	41.50
FLAT SOCKET	6-7943	42.00

### SEDAN DELIVERY LIFTGATE BOLT KIT

BUTTON/FLAT SOCKET	6-1001	16.75
ORIGINAL STYLE	6-1006	19.50

## KITS FOR 1958 FULL SIZE CHEVYS

### BODY & SUSPENSION KITS FOR 1958-1968 FULL SIZE CHEVYS (BELAIR, BISCAYNE, IMPALA)

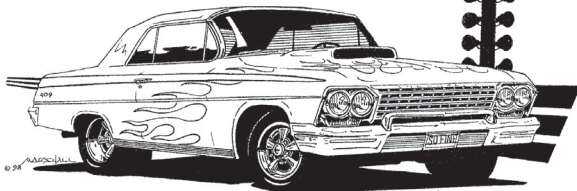

**BODY KIT-** Includes 720 Pieces in component kits for Bumpers, Door Hinges, Door Jambs, Door Latches & Strikers, Firewall & Cowl, Front & Inner Fenders, Gas Filler Door, Grill & Gravel Pan, Hood Latch & Catch & Trim, Hood Hinges, Headlights & Turn Signals, Interior (139 Pieces!), Radiator/Core Support, Horns, & Front Body Mount, Seat Mount, Splash Pans Under Radiator, Tail Lights & Trunk Hinges, Latch & Catch.

\*\* NOTE INDENTED HEX, & ORIGINAL STYLE BOLTS ARE MADE IN USA \*\*

### PICK YOUR BOLT STYLE!

BUTTON & SOCKET HEAD  
INDENTED HEX HEAD  
ORIGINAL STYLE-INDENTED HEX  
WITH BLACK STAINLESS (WHERE APPROPRIATE)

### Part #

# 6-8800  
6-8802  
6-8803

### Price:

\$ 440.00  
499.00  
525.00

## ACCESSORY KITS (NOT INCLUDED IN THE BODY KIT)

### BODY MOUNT KITS - SUPPLEMENTAL

TO THE FRONT BODY MOUNT KIT (12 BOLTS & WASHERS)

SIX POINT HEAD - HIGH STRENGTH	# 6-8868	\$135.00
12 POINT HEAD - HIGH STRENGTH	6-8869	140.00

### CONVERTIBLE INTERIOR DOOR & QUARTER PANELS KIT

PHILLIPS OVAL	6-8851	12.00
---------------	--------	-------

### CONVERTIBLE TOP CATCHES & LATCHES

POLISHED OVAL HEAD	6-8850	12.00
--------------------	--------	-------

### ENGINE KITS - SEE PAGES 19-23

### REAR DOORS KIT - FOR 4 DOOR CARS

BUTTON/FLAT SOCKET	6-8855	62.00
ORIGINAL STYLE	6-8856	52.50

### CHASSIS KIT - INCLUDES FRONT & REAR

SUSPENSION PLUS STEERING BOX

SIX POINT - HIGH STRENGTH	# 6-8872	\$ 740.00
---------------------------	----------	-----------

### FRONT SUSPENSION KITS (117 PIECES!)

-COMPLETE WITH GREASE FITTING & COTTER PINS

\*\*CASTLE NUTS NOT INCLUDED - SEE PAGE 130\*\*

SIX POINT - HIGH STRENGTH	6-8870	455.00
---------------------------	--------	--------

### REAR SUSPENSION KIT

\*\*DOES NOT INCLUDE THE SHOULDERED "L" BOLTS\*\*

SIX POINT - HIGH STRENGTH	6-8871	210.00
---------------------------	--------	--------

### STEERING BOX KIT

SIX POINT - HIGH STRENGTH	6-8950	75.00
---------------------------	--------	-------

### TRANSMISSION & REAR COVER KITS

-SEE PAGES 29-31

# KITS FOR 1959-1960 FULL SIZE CHEVYS

**BODY KIT-** Every Body Kit includes component kits for Bumpers, Cowl Cover, Door Hinges, Door Jambs, Filler Panel (Stone Guard), Front Body Mount, Front & Inner Fenders, Hood Latch & Catch, Hood Hinges, Headlights & Turn Signals, Interior, License Plate & Light, Radiator/Core Support, Battery Box, & Front Body Mount, Seat Mount, Tail Lights & Trunk Hinges, Latch & Catch (Tail gate, etc in El Camino kit).

Contains one of each component kit for:	<b>FULL SIZE CARS - 783 pc</b>		<b>EL CAMINO - 930 pc</b>	
BUTTON & SOCKET HEAD	# 6-8900	\$ 475.00	# 6-8990	\$ 550.00
INDENTED HEX HEAD	6-8902	575.00	6-8991	650.00
ORIGINAL STYLE-INDENTED HEX WITH BLACK STAINLESS (WHERE APPROPRIATE)	6-8903	595.50	6-8992	675.00

\*\* NOTE INDENTED HEX, & ORIGINAL STYLE BOLTS ARE MADE IN USA \*\*

## ACCESSORY KITS (NOT INCLUDED IN THE BODY KIT)

**CHASSIS KIT** - INCLUDES FRONT & REAR SUSPENSION PLUS STEERING BOX  
SIX POINT - HIGH STRENGTH # 6-8959 \$ 920.00

**FRONT SUSPENSION KIT**  
-COMPLETE WITH GREASE FITTINGS & COTTER PINS  
\*\*CASTLE NUTS NOT INCLUDED - SEE PAGE 130\*\*  
SIX POINT - HIGH STRENGTH 6-8951 515.00

**REAR SUSPENSION KIT**  
-DOES NOT INCLUDE SHOULDERED "L" BOLTS  
SIX POINT - HIGH STRENGTH 6-8952 325.00

**TRANSMISSION KITS** - SEE PAGE 29

**STEERING BOX KIT**  
SIX POINT - HIGH STRENGTH # 6-8950 \$ 75.00

**BODY MOUNT KITS** - SUPPLEMENTAL TO THE FRONT BODY MOUNT KIT (10 BOLTS & WASHERS)  
HEX HEAD 6-8946 63.25  
SOCKET HEAD 6-8947 83.25  
SIX POINT HEAD - HIGH STRENGTH 6-8970 143.50  
12 POINT HEAD - HIGH STRENGTH 6-8971 147.25

**CONVERTIBLE TOP TRIM KIT - 40 pc**  
ORIGINAL STYLE - SCREWS & SNAPS 6-8948 20.00

**ENGINE KITS** - SEE PAGES 17-21

# KITS FOR 1961-1964 FULL SIZE CHEVYS

**BODY KIT-** Every Body Kit includes component kits for Bumpers, Door Hinges, Door Jambs, Filler Panel (Stone Guard), Firewall, Front & Inner Fenders, Gas Tank, Hood Latch & Hinges, Headlights & Turn Signals, Interior, Radiator/Core Support/Front Body Mount, Battery Box, Tail Lights & Trunk Hinges, Latch & Catch.

Contains one of each component kit - 731 PIECES!	<b>1961</b>		<b>1962</b>		<b>1963-1964</b>	
BUTTON & SOCKET HEAD	# 6-8200	\$ 525.00	# 6-8247	\$ 499.00	# 6-8250	\$ 540.00
HEX HEAD	6-8201	534.50	6-8965	480.50	6-8251	532.00
INDENTED HEX HEAD	6-8202	599.00	6-8248	530.25	6-8252	620.00
WITH BLACK STAINLESS (WHERE APPROPRIATE)	6-8230	640.00	6-8249	620.00	6-8253	660.00
SIX POINT (SMALL HEX FLANGE HEAD) - POLISHED	6-8246	1397.25	6-8273	1244.75	6-8274	1403.50

\*\* NOTE INDENTED HEX, ORIGINAL STYLE, & SIX POINT BOLTS ARE MADE IN USA \*\*

## ACCESSORY KITS (NOT INCLUDED IN THE BODY KIT)

**CHASSIS KIT** - INCLUDES ALL KITS WITH AN \* BESIDE THE TITLE # 6-8961 \$ 999.00

**BRAKE & FUEL LINES KITS \***  
BUTTON HEAD 6-8276 7.00  
INDENTED HEX 6-8277 9.75

**ENGINE MOUNTS TO FRAME KITS\***  
SIX POINT - HIGH STRENGTH 6-8949 72.00  
TWELVE POINT - HIGH STRENGTH 6-8953 75.00

**FRONT SUSPENSION KIT \* - 110 PIECES!**  
-COMPLETE WITH GREASE FITTINGS & COTTER PINS  
\*\*CASTLE NUTS NOT INCLUDED - SEE PAGE 130\*\*  
SIX POINT - HIGH STRENGTH 6-8951 515.00

**STEERING BOX KIT\***  
SIX POINT - HIGH STRENGTH 6-8950 75.00

**REAR SUSPENSION \***  
-DOES NOT INCLUDE SHOULDERED "L" BOLTS  
SIX POINT - HIGH STRENGTH 6-8952 325.00

**TRANSMISSION CROSSMEMBER KITS\***  
SIX POINT - HIGH STRENGTH 6-8974 35.00  
TWELVE POINT - HIGH STRENGTH 6-8975 37.00

**BODY MOUNT KITS** - SUPPLEMENTAL TO THE FRONT BODY MOUNT KIT (12 BOLTS & WASHERS)  
HEX HEAD 6-8272 68.00  
SOCKET HEAD 6-8275 99.75  
SIX POINT HEAD - HIGH STRENGTH 6-8289 187.00  
12 POINT HEAD - HIGH STRENGTH 6-8290 190.00

**ENGINE KITS** - SEE PAGES 19-23

**TRANSMISSION KITS** - SEE PAGE 29



**BIG BROTHER'S AIR BAGGED IMPALA, POWERED BY A 350TPI WITH A 700-R4**





# KITS FOR 1965-1968 FULL SIZE CHEVYS

**BODY KIT-** Every Body Kit includes component kits for Bumpers, Door Hinges, Door Jambs, Firewall & Cowl, Front Body Mount, Front & Inner Fenders, Gas Tank, Hood Latch & Hinges, Grill, Headlights & Turn Signals, Interior (130 Pieces!), Radiator/Core Support, Battery Box, Rear Window Trim, Seat Mount, Tail Lights & Trunk Hinges, Latch & Catch & Trunk Lid Trim/Light/Catch.

Contains one of each component kit

	1965-1966		1967-1968	
	CONVERTIBLE	SEDAN / H-TOP	SEDAN / H-TOP	
	791 PIECES	676 PIECES	756 PIECES	
BUTTON AND SOCKET HEAD	# 6-8343 \$ 410.00	# 6-8300 \$ 399.00	# 6-8400 \$ 405.00	
INDENTED HEX HEAD	6-8344 520.00	6-8301 505.00	6-8402 555.00	
ORIGINAL STYLE-INDENTED HEX	6-8345 575.00	6-8302 550.00	6-8403 599.00	

WITH BLACK STAINLESS (WHERE APPROPRIATE)

\*\* NOTE INDENTED HEX, & ORIGINAL STYLE BOLTS ARE MADE IN USA \*\*

## ACCESSORY KITS (NOT INCLUDED IN THE BODY KIT)

**CHASSIS KIT** - 1965-67: INCLUDES FRONT & REAR SUSPENSION, STEERING BOX, TRANSMISSION CROSS-MEMBER, & ENGINE MOUNT TO FRAME KITS  
SIX POINT - HIGH STRENGTH # 6-8340 \$ 915.00

### ENGINE MOUNTS TO FRAME KITS

SIX POINT - HIGH STRENGTH 6-1945 45.50  
TWELVE POINT - HIGH STRENGTH 6-1946 49.50

### FRONT SUSPENSION KITS

-1965-1967 (104 PIECES!): COMPLETE WITH GREASE FITTINGS & COTTER PINS. -DOES NOT INCLUDE THE (2) CAM BOLTS, \*CASTLE NUTS NOT INCLUDED - SEE PAGE 130\*  
SIX POINT - HIGH STRENGTH 6-8338 322.00

### REAR SUSPENSION KIT

-1965-67 (44 PIECES)  
-CONTAINS BOLTS FOR DUAL UPPER CONTROL ARMS  
SIX POINT - HIGH STRENGTH 6-8336 415.00

### STEERING BOX KITS

1965-1967  
SIX POINT - HIGH STRENGTH # 6-8334 \$ 55.50

### TRANSMISSION CROSSMEMBER KIT

SIX POINT - HIGH STRENGTH 6-1768 39.50  
TWELVE POINT - HIGH STRENGTH 6-1771 42.00

### BODY MOUNT KITS - SUPPLEMENTAL

TO THE FRONT BODY MOUNT KIT (8 BOLTS & 8 WASHERS)

\*\* BUY (2) KITS FOR CONVERTIBLES - THEY NEED 16! \*\*

HEX HEAD 6-8980 44.75  
SOCKET HEAD 6-8981 63.25  
SIX POINT HEAD - HIGH STRENGTH 6-8982 120.00  
12 POINT HEAD - HIGH STRENGTH 6-8983 125.00

### DOOR STRIKER BOLTS & WASHERS - 1 PAIR

SOCKET HEAD 6-8154 59.95

### ENGINE KITS - SEE PAGES 19-23

# KITS FOR 1991-1996 CAPRICE/IMPALA

**BODY KIT-** Every Body Kit includes component kits for Bumpers, Door Hinges, Door Jambs, Firewall & Cowl, Front Body Mount, Front & Inner Fenders, Gas Tank, Hood Latch & Hinges, Grill, Headlights & Turn Signals, Interior (130 Pieces!), Radiator/Core Support, Battery Box, Trunk Seal, Seat Mount, Tail Lights & Trunk Hinges, Latch & Catch & Trunk Lid Trim/Light/Catch.

Contains one of each component kit

BUTTON HEAD	# 5-2001	\$350.00
HEX HEAD	5-2002	325.00

## ACCESSORY KITS (NOT INCLUDED IN THE BODY KIT)

**CHASSIS KIT** - INCLUDES ALL KITS WITH AN \* BESIDE THE TITLE - HIGH STRENGTH

1994-95 WITH STOCK TRAILING ARMS: # 5-2094 \$ 935.00  
1996 WITH BOXED TRAILING ARMS: 5-2099 965.00

### ENGINE MOUNTS TO FRAME KIT\*

SIX POINT - HIGH STRENGTH 5-2093 80.00

**SUSPENSION KITS\*** - FOR USE WITH STOCK BUSHINGS COMPLETE WITH GREASE FITTINGS & COTTER PINS, \*\*CASTLE NUTS NOT INCLUDED - SEE PAGE 130\*\*

-DOES NOT INCLUDE SWAY BAR KIT FOR REAR - (NEED TO KNOW IF CONTROL ARMS ARE BOXED)  
FRONT: SIX POINT - HIGH STRENGTH 5-2090 415.00  
REAR: SIX POINT - HIGH STRENGTH 5-2097 276.00

### STEERING BOX KIT \*

SIX POINT - HIGH STRENGTH # 5-2091 \$ 50.00

### SWAY BAR KITS\* - HIGH STRENGTH

- FOR 1994 & 1995 CARS WITH STOCK TRAILING ARMS:  
5-0000 55.50  
- FOR 1996 CARS & ALL YEARS WITH BOXED TRAILING ARMS  
5-2000 87.50

### TRANSMISSION CROSSMEMBER KIT \*

SIX POINT - HIGH STRENGTH 5-2095 55.00

### ENGINE KITS - SEE PAGES 21-22

### TRANSMISSION & REAR COVER KITS

- SEE PAGES 29,30, & 31



TOLL FREE ORDER LINE : 1-800-767-4781



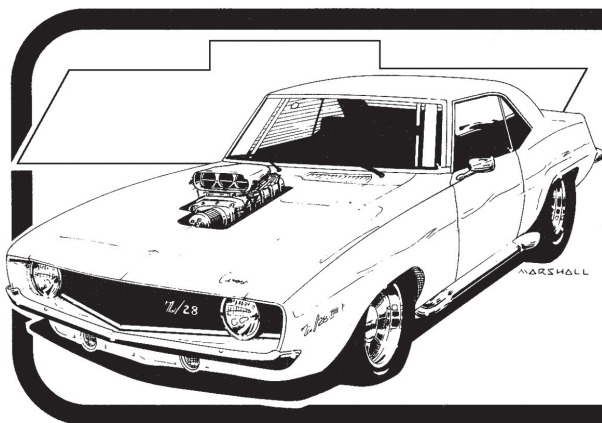

## BODY AND SUSPENSION KITS FOR CAMAROS & FIREBIRDS

### BODY KITS FOR 1967-1969 CAMARO & FIREBIRD

**BODY KIT-** Every Body Kit includes component kits for Front Body Mount, Bumpers, Door Hinges, Door Jambs, Firewall, Front Sheet Metal, Gas Tank Mounting, Grill, Hood Hinges, Interior, Rear Axle Stop, Seat Mount & Trunk Hinges, Latch & Catch. Over 450 Pieces and available in 5 different bolt styles!

#### BODY KITS FOR 1967-69 CAMARO:

	COUPE KITS		CONVERTIBLE KITS	
(Contains one of each component kit)	Part #	Price:	Part #	Price:
BUTTON & SOCKET HEAD (CUSTOM STYLE)	# 6-1639	\$ 275.00	# 6-1592	\$280.00
HEX HEAD	6-1640	310.00		
INDENTED HEX HEAD	6-1691	435.00	6-1593	470.00
ORIGINAL STYLE-INDENTED HEX	6-1692	485.75	6-1594	525.00
WITH BLACK STAINLESS (WHERE APPROPRIATE)				
SIX POINT - POLISHED - HIGH STRENGTH	6-1600	895.00	6-1595	899.00
TWELVE POINT - POLISHED - HIGH STRENGTH	6-1685	936.00	6-1596	945.00

#### BODY KITS FOR 1967-1969 FIREBIRD - OVER 520 PIECES!

BUTTON HEAD (CUSTOM STYLE)	6-2800	285.00	6-2798	299.00
INDENTED HEX HEAD	6-2801	495.00	6-2799	515.00
ORIGINAL STYLE-INDENTED HEX				
WITH BLACK STAINLESS (WHERE APPROPRIATE)	6-2802	530.00	6-2817	540.00
SIX POINT - POLISHED - HIGH STRENGTH	6-2803	978.00	6-2830	990.00
TWELVE POINT - POLISHED - HIGH STRENGTH	6-2804	989.50	6-2829	999.00

\*\* NOTE SIX & TWELVE POINT, INDENTED HEX, & ORIGINAL STYLE BOLTS ARE MADE IN USA \*\*

### ACCESSORY KITS (NOT INCLUDED IN THE BODY KIT)

**CHASSIS KIT** - INCLUDES ALL KITS WITH AN \*  
BESIDE THE TITLE

SIX POINT - HIGH STRENGTH	# 6-1680	\$ 995.00
TWELVE POINT - HIGH STRENGTH	6-1684	1010.00

(SUB FRAME MOUNT KIT IS 6 POINT)

\*\* SEE PAGES 32 & 33 FOR AFTERMARKET KITS \*\*

**FRONT SUSPENSION KIT\*** - 86 PIECES!

-HIGH STRENGTH STAINLESS PLUS GREASE FITTINGS &  
COTTER PINS, \*CASTLE NUTS NOT INCLUDED - SEE PG 130\*

SIX POINT - HIGH STRENGTH	6-1681	455.00
TWELVE POINT	6-1676	460.00

**REAR SUSPENSION KIT\*** - INCLUDES 1/2" U-BOLTS

SIX POINT - HIGH STRENGTH	6-1687	355.00
TWELVE POINT - HIGH STRENGTH	6-1683	360.50

**STEERING BOX COVER & MOUNT\***

SIX POINT - HIGH STRENGTH	6-1607	70.00
---------------------------	--------	-------

TWELVE POINT - HIGH STRENGTH	6-1613	75.00
------------------------------	--------	-------

**SUB-FRAME TO BODY MOUNT KIT\***

- FOR STANDARD BODY BUSHINGS - IN CHASSIS KIT

SIX POINT - HIGH STRENGTH	6-1699	175.00
---------------------------	--------	--------

- FOR SOLID BODY BUSHINGS (3 1/2" BOLTS)

SIX POINT - HIGH STRENGTH	6-1645	177.50
---------------------------	--------	--------

**TRANSMISSION CROSSMEMBER KITS\***

SIX POINT - HIGH STRENGTH	6-1768	39.50
TWELVE POINT - HIGH STRENGTH	6-1771	42.00

**ENGINE KITS** - SEE PAGES 19-23

**CONVERTIBLE TOP ASSEMBLY KITS: 208PC**  
ASSEMBLY LIST & ILLUSTRATION ARE INCLUDED

BUTTON & FLAT SOCKET HEAD	6-2828	499.00
HEX & PHILLIPS HEAD - ORIGINAL STYLE	6-2827	510.00



**HEADER BAR ADJUSTMENT SCREWS** ARE JUST (2) OF THE 208 PC  
IN OUR CONVERTIBLE TOP ASSEMBLY KIT FOR 67-69 CAMAROS. THESE  
ARE AVAILABLE SEPERATELY: 2-8289 \$33.50 EA.

**DOOR STRIKERS KIT** - SOCKET HEAD SHOULDER  
BOLTS WITH WASHERS 6-8154 59.95

**HIDE-AWAY HEAD LIGHTS KIT FOR 67-68 RS**  
ORIGINAL STYLE 6-1635 35.00

**REAR SEAT RIVET REPLACEMENTS**

- SOCKET HEAD SHOULDER BOLTS 2-8187 25.00 EA.

**TRANSMISSION & REAR COVER KITS**

-SEE PAGES 29,30, & 31

# KITS FOR 1970-1981 CAMARO/FIREBIRD

(BODY KITS WORK WELL FOR MOST OF THE PARTS ON FIREBIRDS TOO)

**BODY KIT-** Every Body Kit includes component kits for Front Body Mount, Brake & Fuel Line, Bumpers, Bumper Mounting, Door Hinges, Door Jambs, Headlight & Front Turn Signals, Heater & Air Conditioner Cover, Front/Inner Fenders and Windshield & Recovery Tank, Hood Hinges, Hood Latch & Catch, Interior (70-77), Radiator Support & Battery Box, Rear Axle Stop, Rear Bumper Mount (74-81), Trunk Hinges, Latch, and Windshield Wipers and Cowl Vents.

**KITS FOR CAMAROS: 1970-1973**

BUTTON HEAD	# 6-8000	\$ 265.75
HEX HEAD	6-8001	299.50
INDENTED HEX	6-8002	425.00
ORIGINAL STYLE	6-8003	460.00
-INDENTED HEX WITH BLACK STAINLESS (WHERE APPROPRIATE)		
SIX POINT - POLISHED	6-8087	930.00
12 POINT - POLISHED	6-7851	975.00

**1974-1977**

# 6-8005	\$ 285.00
6-8006	310.00
6-8007	435.00
6-8008	470.00
6-8097	990.50
6-7852	1025.00

**1978-1981**

# 6-8010	\$ 250.00
6-8011	275.00
6-8012	340.00
6-8013	375.00
6-7850	965.00
6-7853	999.00

\*\* NOTE INDENTED HEX, ORIGINAL STYLE, SIX, & TWELVE POINT BOLTS ARE MADE IN USA \*\*

## ACCESSORY KITS (NOT INCLUDED IN THE BODY KIT)

**CHASSIS MASTER KITS** - INCLUDES FRONT & REAR SUSPENSION, STEERING BOX, SUB FRAME TO BODY & TRANSMISSION CROSSMEMBER KITS - HIGH STRENGTH - FOR:

<b>1970-76 CAMARO:</b>	SIX POINT	# 6-8043	\$ 935.00
	TWELVE POINT	6-2847	985.00
<b>1970-72 FIREBIRD:</b>	SIX POINT	6-8094	955.50
	TWELVE POINT	6-2848	999.00
<b>1977-81 CAMARO &amp; 1973-81 FIREBIRD</b>	SIX POINT	6-8053	1070.00
	TWELVE POINT	6-2849	1140.50

**REAR SUSPENSION KIT** - INCLUDES (4) 1/2" U-BOLTS (U-BOLTS ARE USED IN PLACE OF STOCK T-BOLTS)

<b>1970-76:</b>	SIX POINT	# 6-1687	\$ 355.00
	TWELVE POINT	6-2843	320.50
<b>1977-81:</b>	SIX POINT	6-1688	335.50
	TWELVE POINT	6-2844	340.00

**STEERING BOX COVER & MOUNT KIT**

SIX POINT - HIGH STRENGTH	6-8071	65.50
TWELVE POINT - HIGH STRENGTH	6-8075	75.00

**FRONT SUB-FRAME TO BODY MOUNT KIT**

SIX POINT - HIGH STRENGTH	6-8084	165.50
---------------------------	--------	--------

**TRANSMISSION CROSSMEMBER KITS**

SIX POINT - HIGH STRENGTH	6-1768	39.50
TWELVE POINT - HIGH STRENGTH	6-1771	42.00

**FRONT SUSPENSION KIT** - HIGH STRENGTH

\*\*CASTLE NUTS NOT INCLUDED - SEE PAGE 130\*\* KITS FOR:

<b>1970-76 CAMARO:</b>	SIX POINT	6-8048	350.00
	TWELVE POINT	6-8038	399.00
<b>1970-72 FIREBIRD:</b>	SIX POINT	6-8086	370.00
	TWELVE POINT	6-2845	425.00
<b>1977-81 CAMARO &amp; 1973-81 FIREBIRD</b>	SIX POINT	6-8058	465.00
	TWELVE POINT	6-2846	520.50

**TRANSMISSION & REAR COVER KIT**

- SEE PAGES 29 & 30

**DOOR STRIKER BOLTS & WASHERS (PAIR)**

SOCKET HEAD	6-8149	65.00
-------------	--------	-------

**ENGINE KITS** - SEE PAGES 17-24

# KITS FOR 1982-1992 CAMARO/FIREBIRD

**DOOR JAMB KIT** - DOES BOTH DOORS

PHILLIPS HEAD	# 5-0909	\$ 6.25
---------------	----------	---------

**DOOR STRIKER BOLTS & WASHERS**

SOCKET HEAD (PAIR)	6-8149	65.00
--------------------	--------	-------

**HEADLIGHT RETAINING SCREW KIT**

ORIGINAL STYLE	5-0911	4.00
----------------	--------	------

**LICENSE PLATE**

ORIGINAL STYLE	5-0910	4.00
----------------	--------	------

**TRANSMISSION KITS** - SEE PAGE 29-31

**ENGINE KITS** - SEE PAGES 19-24

**FENDERS, CORE SUPPORT, HOOD KITS**

BUTTON HEAD	# 5-0900	\$ 25.00
HEX HEAD	5-0901	25.00
SIX POINT	5-0902	190.00

**REAR COVER KITS** - SEE PAGE 33

**STEERING BOX COVER & MASTER CYLINDER**

SIX POINT - HIGH STRENGTH	5-0903	26.50
TWELVE POINT - HIGH STRENGTH	5-0904	28.00



## BODY & SUSPENSION KITS FOR CHEVELLE, MALIBU, & EL CAMINO

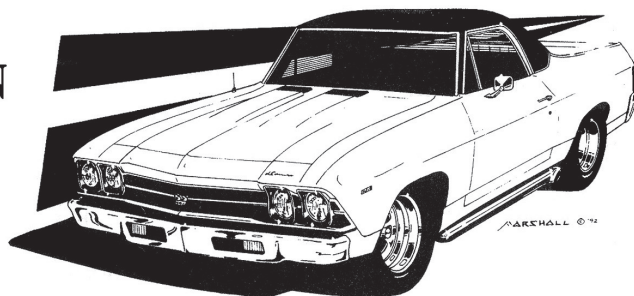

**BODY KIT-** Every Body Kit includes component kits for Bed Floor & Corner Cover (El Camino), Front Body Mount, Bumpers, Door Hinges, Door Jambs, Firewall, Front/Inner Fenders (Splash Pan & Horn for 1966-67), Front Fenders, Radiator Support, Battery Box & Horn, Gas Tank Mounting, 1964-65 Grill, Filler Panels, & Hood Stops, Grill Headlights, & Turn Signals, Hood Hinges, Latch & Catch, Inner Fenders, Interior Trim Screw, Lens Screw, License Plate & Bracket, Seat Mount, Radiator Support, Battery Box, & Windshield Washer, Tailgate (El Camino), Trunk Hinges, Latch & Catch, and Windshield Bottom Trim Screw. 456 to 667 Pieces!

\*\* NOTE INDENTED HEX (ORIGINAL STYLE), SIX & TWELVE POINT BOLTS ARE MADE IN USA \*\*

## BODY KITS FOR 1964-1972 CHEVELLE & EL CAMINO

### 1964-1965 CHEVELLE-543 PIECES

BUTTON/SOCKET HEAD	# 6-8100	\$ 300.00
HEX HEAD	6-8101	310.00
INDENTED HEX HEAD	6-8102	375.00
ORIGINAL STYLE - INDENTED HEX WITH BLACK STAINLESS (WHERE APPROPRIATE)	6-8103	399.00
SIX POINT - HIGH STRENGTH	6-8123	815.00
TWELVE POINT - HIGH STRENGTH	9-1200	860.00

### 1964-1965 EL CAMINO-623 PIECES

BUTTON/SOCKET HEAD	6-8104	340.75
HEX HEAD	6-8105	345.00
INDENTED HEX HEAD	6-8106	395.00
ORIGINAL STYLE - INDENTED HEX WITH BLACK STAINLESS (WHERE APPROPRIATE)	6-8107	455.00
SIX POINT - HIGH STRENGTH	6-8143	845.00
TWELVE POINT - HIGH STRENGTH	9-1220	885.00

### 1966-1967 CHEVELLE-456 PIECES

BUTTON/SOCKET HEAD	6-1927	290.75
HEX HEAD	6-1928	310.00
INDENTED HEX HEAD	6-1929	415.00
ORIGINAL STYLE INDENTED HEX WITH BLACK STAINLESS (WHERE APPROPRIATE)	6-1931	450.00
SIX POINT - HIGH STRENGTH	6-1905	855.00
TWELVE POINT - HIGH STRENGTH	9-1250	900.00

### 1966-1967 EL CAMINO-546 PIECES

BUTTON/SOCKET HEAD	6-1938	325.00
HEX HEAD	6-1939	340.50
INDENTED HEX HEAD	6-1940	450.00
ORIGINAL STYLE - INDENTED HEX WITH BLACK STAINLESS (WHERE APPROPRIATE)	6-1941	495.00
SIX POINT - HIGH STRENGTH	6-1904	915.00
TWELVE POINT - HIGH STRENGTH	9-1260	950.00

### 1968-1969 CHEVELLE-535 PIECES

BUTTON/SOCKET HEAD	# 6-1733	\$ 285.25
HEX HEAD	6-1734	290.75
INDENTED HEX HEAD	6-1736	425.00
ORIGINAL STYLE INDENTED HEX WITH BLACK STAINLESS (WHERE APPROPRIATE)	6-1737	470.00
SIX POINT - HIGH STRENGTH	6-1735	875.00
TWELVE POINT - HIGH STRENGTH	9-1300	925.00

### 1968-1969 EL CAMINO-625 PIECES

BUTTON/SOCKET HEAD	6-1741	325.00
HEX HEAD	6-1742	330.50
INDENTED HEX HEAD	6-1743	460.00
ORIGINAL STYLE - INDENTED HEX WITH BLACK STAINLESS (WHERE APPROPRIATE)	6-1744	495.00
SIX POINT - HIGH STRENGTH	6-1760	900.50
TWELVE POINT - HIGH STRENGTH	9-1310	935.50

### 1970-72 CHEVELLE-577 PIECES

BUTTON/SOCKET HEAD	6-1780	320.50
HEX HEAD	6-1781	330.00
INDENTED HEX HEAD	6-1783	459.00
ORIGINAL STYLE - INDENTED HEX WITH BLACK STAINLESS (WHERE APPROPRIATE)	6-1784	490.00
SIX POINT - HIGH STRENGTH	6-1785	910.00
TWELVE POINT - HIGH STRENGTH	9-1350	925.00

### 1970-1972 EL CAMINO-667 PIECES

BUTTON/SOCKET HEAD	6-1790	365.00
HEX HEAD	6-1791	370.75
INDENTED HEX HEAD	6-1792	490.00
ORIGINAL STYLE INDENTED HEX WITH BLACK STAINLESS (WHERE APPROPRIATE)	6-1793	525.00
SIX POINT - HIGH STRENGTH	6-1789	945.00
TWELVE POINT - HIGH STRENGTH	9-1360	955.50

\* **SIX POINT & TWELVE POINT KITS CONTAIN POLISHED BOLTS** \*

**-SEE NEXT PAGE FOR ACCESSORY KITS-**

# ACCESSORY KITS (NOT INCLUDED IN THE BODY KIT)

## CHASSIS MASTER KIT - INCLUDES FRONT & REAR SUSPENSION, STEERING BOX, ENGINE MOUNTS & TRANSMISSION CROSSMEMBER KITS

SIX POINT - HIGH STRENGTH	# 6-8161	\$ 799.50
TWELVE POINT - HIGH STRENGTH	6-8199	815.00

### AC CONDENSER MOUNT KITS - 1968-72

BUTTON HEAD	# 6-1798	\$ 9.75
HEX HEAD	6-1799	10.00
INDENTED HEX HEAD	6-1772	15.00
ORIGINAL STYLE - WITH BLACK STAINLESS WHERE APPROPRIATE	6-1774	17.50
SIX POINT - HIGH STRENGTH	6-1930	25.00
TWELVE POINT - HIGH STRENGTH	6-1954	28.50

### BUCKET SEAT TRIM KIT - 1964-65

PHILLIPS HEAD	6-8144	8.00
---------------	--------	------

### BODY MOUNT KITS - SUPPLEMENT TO FRONT MOUNT: SEDANS & HARD TOPS: (8 BOLTS & WASHERS)

HEX HEAD	6-1948	43.75
SOCKET HEAD	6-1949	62.25
SIX POINT - HIGH STRENGTH	6-1955	110.00
TWELVE POINT - HIGH STRENGTH	6-1958	117.50

### CONVERTIBLES, EL CAMINO & WAGONS: (12 BOLTS & WASHERS)

HEX HEAD	6-1951	64.00
SOCKET HEAD	6-1952	92.00
SIX POINT - HIGH STRENGTH	6-1953	165.00
TWELVE POINT - HIGH STRENGTH	6-1959	173.50

### CONVERTIBLE HEADER BAR

PHILLIPS OVAL JACKSON	6-1762	11.50
-----------------------	--------	-------

### DOOR STRIKER BOLTS & WASHERS

- HIGH STRENGTH 17-4 PH STAINLESS FOR LONGER WEAR		
SOCKET HEAD (PAIR)	6-8154	59.95



### REAR SWAY BAR KIT

SIX POINT - HIGH STRENGTH	6-8185	51.50
TWELVE POINT - HIGH STRENGTH	6-8186	53.50

### ENGINE KITS - SEE PAGES 19-23

### ENGINE MOUNT TO FRAME KITS\*

SIX POINT - HIGH STRENGTH	# 6-1945	\$ 45.50
TWELVE POINT - HIGH STRENGTH	6-1946	49.50

### REAR COVER KITS - SEE PAGE 31

### STEERING BOX COVER & MOUNT KITS\*

SIX POINT - HIGH STRENGTH	6-1936	65.00
TWELVE POINT - HIGH STRENGTH	6-1937	72.00

### FRONT & REAR SUSPENSION KITS\*

- HIGH STRENGTH STAINLESS BOLTS COMPLETE WITH SPECIAL WASHERS, SWAY BAR END LINKS WITH SPACERS, GREASE ZERKS & COTTERS

\*\*CASTLE NUTS NOT INCLUDED - SEE PAGE 130\*\*

SIX POINT - HIGH STRENGTH	6-8156	580.00
TWELVE POINT - HIGH STRENGTH	6-8198	585.00

### TRANSMISSION CROSSMEMBER KITS\*

SIX POINT - HIGH STRENGTH	6-1768	39.50
TWELVE POINT - HIGH STRENGTH	6-1771	42.00

### TRANSMISSION KITS - SEE PAGE 31-32

### WHEEL WELL MOULDING KIT

ORIGINAL STYLE - ROUND WASHER HEAD	6-1796	8.00
CUSTOM STYLE - BUTTON HEAD	6-1764	9.00

### REAR SHOCK MOUNT STUD KIT - CUSTOM

MADE HIGH STRENGTH 17-4 PH STUDS WITH NUTS & WASHERS		
	6-8170	86.50



TOLL FREE ORDER LINE : 1-800-767-4781



# KITS FOR 1978 - 1987 MALIBU & EL CAMINO

## BUMPER KITS

### -FRONT BUMPER

BUTTON HEAD	# 5-0821	\$ 19.00
HEX HEAD	5-0822	17.50

### -REAR BUMPER

BUTTON HEAD	5-0835	16.50
HEX HEAD	5-0836	15.00

## BATTERY BOX & HOLD DOWN KITS

BUTTON HEAD	5-0806	8.00
HEX HEAD	5-0807	7.75

## DOOR HINGES KITS - DOES BOTH

HEX HEAD	5-0812	40.00
SOCKET HEAD	5-0813	40.00

## DOOR LATCH KITS - DOES BOTH

FLAT SOCKET	5-0837	4.00
PHILLIPS HEAD	5-0838	4.00

## DOOR STRIKER BOLTS & WASHERS

SOCKET HEAD (PAIR)	6-8149	65.00
--------------------	--------	-------

## ENGINE KITS - SEE PAGES 19-23

## FRONT BODY MOUNT KITS

HEX HEAD	5-0833	24.00
SOCKET HEAD	5-0834	24.25

## FRONT & INNER FENDER KITS

BUTTON HEAD	5-0827	38.50
HEX HEAD	5-0828	36.00

## FRONT SUSPENSION KITS

### 1978 THRU EARLY 1980 (US THREAD) - A BODY

SIX POINT - HIGH STRENGTH	6-8096	399.00
12 POINT - HIGH STRENGTH	6-8142	425.00

### LATE 1980 & LATER (METRIC THREAD) - G BODY

SIX POINT - HIGH STRENGTH	5-0899	383.00
12 POINT - HIGH STRENGTH	5-0896	398.50

## REAR SUSPENSION KITS

### 1978 THRU EARLY 1980 (US THREAD) - A BODY

SIX POINT - HIGH STRENGTH	6-8188	187.00
12 POINT - HIGH STRENGTH	6-8189	209.50

### LATE 1980 & LATER (METRIC THREAD) - G BODY

SIX POINT - HIGH STRENGTH	5-0898	181.50
12 POINT - HIGH STRENGTH	5-0897	187.00

## GAS TANK MOUNT KITS

HEX HEAD	# 5-0819	\$ 12.00
SOCKET HEAD	5-0820	13.00
TWELVE POINT - HIGH STRENGTH	5-0845	50.00

## GRILL & PLASTIC EXTENSION KITS

BUTTON HEAD	5-0824	13.00
HEX HEAD	5-0825	13.00

## HOOD HINGES KITS - DOES BOTH

BUTTON HEAD	5-0809	9.25
HEX HEAD	5-0810	8.00

## MAIN BODY MOUNT KITS

HEX HEAD	5-0843	58.50
SOCKET HEAD	5-0844	59.00

## HOOD LATCH & CATCH KITS

BUTTON HEAD	5-0803	8.50
HEX HEAD	5-0804	8.00

## RADIATOR SUPPORT KITS

BUTTON HEAD	5-0800	10.50
HEX HEAD	5-0801	11.00

## REAR COVER KITS - SEE PAGE 31

## TRANSMISSION KITS - SEE PAGE 29-31

## TRUNK HINGES & LATCH KITS

BUTTON HEAD	5-0814	9.00
HEX HEAD	5-0815	9.00

## WASHER & OVERFLOW TANKS KITS

BUTTON HEAD	5-0830	6.00
HEX HEAD	5-0831	6.50
TWELVE POINT - HIGH STRENGTH	5-0846	22.00

## STEERING BOX MOUNT & COVER KIT

SIX POINT - HIGH STRENGTH	6-8071	65.50
TWELVE POINT - HIGH STRENGTH	6-8075	75.00

## STATION WAGON TAILGATE KITS

BUTTON HEAD	5-0538	21.00
HEX HEAD	5-0539	21.00

## TAILGATE KITS FOR EL CAMINO

BUTTON HEAD	5-0817	15.00
HEX HEAD	5-0818	13.00

## TAILGATE CABLE BOLTS (SET OF 4)

SOCKET HEAD	5-0840	107.00
-------------	--------	--------

# KITS FOR 1965-1966 CORVAIR

**BODY KITS** - Every Body Kit includes component kits for Interior, Parking Brake, Seat Mount, Steering Column, Door Jamb, Door Hinges, Front Bumper, Front Brake Hose Bracket & Speedo Cable Bracket, Headlights & Horn, Fuel Tank Door & Tank Straps, Front Deck Lid, Windshield Washer Bottle, Wiper Linkage to Cowl, Front Ballast Cans, Rear Ballast Cans, Rear Cove Trim, Rear Roll Pan & License Plate, Rear Deck Vent Panel, Rear Bumper, Misc. Engine Compartment, and Spare Tire Bracket.

Contains one of each component kit

	<b>SEDAN</b>		<b>CONVERTIBLE</b>	
BUTTON HEAD	# 6-9500	\$ 275.00	# 6-9567	\$ 280.00
HEX HEAD	6-9501	285.00	6-9568	290.50
ORIGINAL STYLE - INDENTED HEX WITH BLACK STAINLESS WHERE APPROPRIATE	6-9502	375.00	6-9569	399.00

\*\* NOTE ORIGINAL STYLE BOLTS ARE MADE IN USA \*\*

## ACCESSORY KITS (NOT INCLUDED IN THE BODY KIT)

### ENGINE KIT - 190 pc. -1965/66:

BUTTON HEAD	# 6-9555	\$ 65.50
INDENTED HEX - ORIGINAL STYLE	6-9556	143.00

### DOOR STRIKER BOLTS & WASHERS - 1 PAIR

WITH ORIGINAL STYLE WASHERS	
SOCKET HEAD	# 6-8148 \$ 85.75

**BODY &  
CHASSIS KITS  
FOR 1953-78  
CORVETTES**

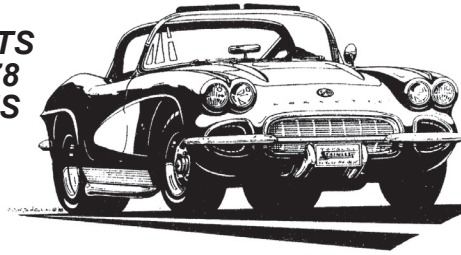

## KITS FOR 1953-1962 CORVETTE

**BODY KIT-** Every Body Kit includes component kits for Battery Heat Shield, Door Hinges, Door Strikers, Firewall, Front Bumper & Mount, Front License Plate Brackets, Grill - with spacers (58-62), Hood Hinges & Brace, Hood Catch, Hood Latches & Stops, Horn, Interior Trim, Radiator/Core Support/Front Mount, Rear Bumpers, Seat Mount, Trunk & Deck Hinges, Latch & Catch, and Washer Tank Bracket & Horn Relay.

	<b>1953-55:</b>	<b>1956-57:</b>	<b>1958-60:</b>	<b>1961-62:</b>
BUTTON HEAD	# 9-6400 \$ 260.50	9-6450 310.75	6-4500 370.75	6-4526 370.75
ORIGINAL STYLE-INDENTED HEX HEAD	9-6401 390.00	9-6451 435.00	6-4524 499.00	6-4510 505.00

\*\* NOTE ORIGINAL STYLE BOLTS ARE MADE IN USA \*\*

### ACCESSORY KITS (NOT INCLUDED IN THE BODY KIT)

#### **57-62 CONVERTIBLE TOP KITS - 142 PIECES**

- ALL SHOULDER BOLTS ARE HIGH STRENGTH 17-4 PH  
STAINLESS - MADE IN OUR SHOP

BUTTON HEAD - CUSTOM (SHOWN BELOW)	# 6-4550 \$ 375.00
SLOTTED PAN HEAD - ORIGINAL STYLE	6-4551 405.00



#### **1957-62 RIVET REPLACEMENT KIT**

BUTTON HEAD (SHOWN BELOW)	6-4552	318.50
SHOULDERED RIVET KIT	6-4557	318.50

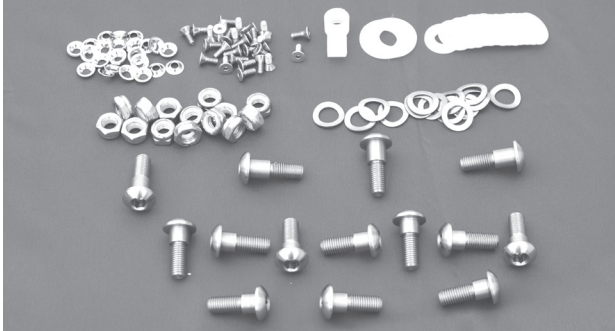

#### **THE BUTTON HEAD RIVET REPLACEMENT KIT**

INCLUDES SHOULDER BOLTS AND LOCK NUTS TO REPLACE THE RIVETS - THE SHOULDERED RIVET KIT HAS RIVETS WITH HOLLOW ENDS WHICH ARE FLARED WHEN INSTALLED

#### **HARD TOP LATCHES KIT**

POLISHED OVAL HEAD	6-4520	10.50
--------------------	--------	-------

#### **INSIDE HARD TOP TRIM KIT**

POLISHED OVAL HEAD	6-4521	7.00
--------------------	--------	------

#### **BODY MOUNT KITS - SUPPLEMENT TO FRONT MOUNT: 1953-67:**

HEX HEAD	# 9-6441	\$ 26.25
SOCKET HEAD	9-6442	27.75
SIX POINT - HIGH STRENGTH	9-6445	95.00
TWELVE POINT - HIGH STRENGTH	9-6446	99.00

#### **1958-62:**

HEX HEAD	6-4523	27.50
SOCKET HEAD	6-4528	28.00
SIX POINT - HIGH STRENGTH	6-4561	95.50
TWELVE POINT - HIGH STRENGTH	6-4562	99.50

#### **ENGINE KITS - SEE PAGES 19-23**

#### **ENGINE MOUNT TO FRAME KIT**

SIX POINT - HIGH STRENGTH	6-4522	45.00
---------------------------	--------	-------

#### **REAR COVER KITS - SEE PAGE 33**

#### **STEERING BOX COVER & MOUNT KITS**

SIX POINT - HIGH STRENGTH	6-4554	58.00
TWELVE POINT - HIGH STRENGTH	6-4555	62.00

#### **SUSPENSION KITS - HIGH STRENGTH**

##### **FRONT SUSPENSION:**

SIX POINT - POLISHED	6-4556	499.00
TWELVE POINT - POLISHED	6-4558	515.00

##### **REAR SUSPENSION:**

##### **1953-55:**

SIX POINT - POLISHED	6-4558	340.00
TWELVE POINT - POLISHED	6-4559	352.50

##### **1956:**

SIX POINT - POLISHED	6-4568	340.50
TWELVE POINT - POLISHED	6-4569	355.00

##### **1957-58:**

SIX POINT - POLISHED	6-4570	355.00
TWELVE POINT - POLISHED	6-4563	365.50

##### **1959:**

SIX POINT - POLISHED	6-4564	405.00
TWELVE POINT - POLISHED	6-4565	445.00

##### **1960-62:**

SIX POINT - POLISHED	6-4566	487.00
TWELVE POINT - POLISHED	6-4567	495.50

- SEE PAGE 130 FOR CASTLE NUTS -

#### **TRANSMISSION KITS - SEE PAGE 29-31**

**TOLL FREE ORDER LINE : 1-800-767-4781**

# KITS FOR 1963-1967 CORVETTE

**BODY KIT-** Each Body Kit includes component kits for Battery Tray/Inner Shields, Back Up & Tail Lights, Brake & Fuel Lines, Cowl Vents, Door Catches, Door Hinges, Door Jambs, Firewall, Floor Pan Shields, Front Bumper & Mount, Front Turn Signals, Gas Filler, Gas Tank Mount, Grill(1965-67), Headlights, Hood Hinges & Brace, Horn & Radiator Mount, Interior Trim, Rear Bumpers, Rear License & Bracket, Roll Pan, Seat Mount & Trim, Spare Tire Crossmember, and Washer Tank Bracket/Relay/Regulator Mounts.

	<b>1963-64:</b>		<b>1965-67:</b>	
BUTTON & FLAT SOCKET HEAD	# 6-4652	\$ 355.00	# 6-4630	\$ 365.75
ORIGINAL STYLE-INDENTED HEX HEAD	6-4601	500.00	6-4602	660.00
WITH BLACK STAINLESS (WHERE APPROPRIATE)				
12 POINT(POLISHED) W/ BUTTON SHEET METAL SCREWS & FLAT SOCKET HEAD	6-4654	1195.00	6-4655	1399.00

\*\* NOTE ORIGINAL STYLE and 12 POINT BOLTS ARE MADE IN USA \*\*

## ACCESSORY KITS (NOT INCLUDED IN THE BODY KIT)

### BODY MOUNT KITS

#### 1963:

HEX HEAD	# 6-4680	\$ 44.25
SOCKET HEAD	6-4681	64.25
SIX POINT - HIGH STRENGTH	6-4682	115.00
TWELVE POINT - HIGH STRENGTH	6-4683	120.50

#### 1964-67 CONVERTIBLE:

HEX HEAD	6-4685	90.00
SOCKET HEAD	6-4686	108.00
SIX POINT - HIGH STRENGTH	6-4688	199.50
TWELVE POINT - HIGH STRENGTH	6-4687	205.00

#### 1964-67 COUPE:

HEX HEAD	6-4626	63.75
SOCKET HEAD	6-4649	95.50
SIX POINT - HIGH STRENGTH	6-4661	180.00
TWELVE POINT - HIGH STRENGTH	6-4657	185.00

### ENGINE KITS - SEE PAGES 17-21

### HIDDEN DOOR HINGE BOLTS KIT

ORIGINAL STYLE (32 BOLTS)	# 6-4684	\$ 125.00
---------------------------	----------	-----------

### SIDE OUTLET EXHAUST KIT

ORIGINAL STYLE	6-4629	13.75
----------------	--------	-------

### SUSPENSION KITS - SIX POINT - POLISHED

\*\*CASTLE NUTS NOT INCLUDED - SEE PAGE 130\*\*

FRONT SUSPENSION - HIGH STRENGTH	6-4796	499.00
REAR SUSPENSION - HIGH STRENGTH	6-4799	650.00

### TRANSMISSION KITS -SEE PAGE 29-31

# KITS FOR 1968-1976 CORVETTE

**BODY KIT-** Every Body Kit includes component kits for Brake, Fuel & Emergency Brake Lines, Cowl Vent/Wiper Cover, Door Hinges, Door Jambs, Firewall (misc.), Firewall Access Cover, Front Air Spoiler, Front Bumper & Mount, Front Crossmember, Front License Plate & Brackets, Gas Tank Mount, Grill & Front Turn Signals, Headlights, Heater/AC Box, Hood Hinges & Brace, Hood Latches & Catches, Inner Fender Shields, Tanks, Interior, Nose Reinforcing Braces, Radiator Support & Shroud, Rear Bumper, Rear License & Bracket, Roll Pan, Seat Mount & Trim, Tail Light, and Wiper Linkage, etc.

	<b>1968-69:</b>		<b>1970-72:</b>		<b>1973:</b>	
BUTTON HEAD & FLAT SOCKET HEAD	# 6-4754	\$ 375.00	# 6-4755	\$380.00	# 6-4742	\$ 350.00
ORIGINAL STYLE - INDENTED HEX HEAD*	6-4702	599.00	6-4703	549.00	6-4743	616.00
	<b>1974:</b>		<b>1975:</b>		<b>1976:</b>	
BUTTON HEAD & FLAT SOCKET HEAD	6-4744	355.00	6-4746	455.00	6-4748	460.50
ORIGINAL STYLE - INDENTED HEX HEAD*	6-4745	632.00	6-4747	690.00	6-4749	695.00

\* WITH BLACK STAINLESS (WHERE APPROPRIATE) \*\* ORIGINAL STYLE BOLTS ARE MADE IN USA \*\*

## ACCESSORY KITS (NOT INCLUDED IN THE BODY KIT)

### BODY MOUNT KITS - SUPPLEMENT TO FRONT MOUNT (FOR STOCK TYPE MOUNTS):

#### 1968-72:

HEX HEAD	# 6-4730	\$ 55.50
SOCKET HEAD	6-4739	76.50
SIX POINT - HIGH STRENGTH	6-4740	130.50
TWELVE POINT - HIGH STRENGTH	6-4741	137.00

#### 1973-82:

HEX HEAD	6-4790	50.50
SOCKET HEAD	6-4791	75.00
SIX POINT - HIGH STRENGTH	6-4792	145.00
TWELVE POINT - HIGH STRENGTH	6-4793	147.50

### DOOR STRIKER BOLTS & WASHERS

SOCKET HEAD (PAIR)	# 6-8154	\$ 59.95
--------------------	----------	----------

### ENGINE KITS - SEE PAGES 19-23

### REAR END COVER KITS - SEE PAGE 31

### SUSPENSION KITS - SEE PAGE 130 FOR CASTLE NUTS -

### SIX POINT HEAD STYLE - HIGH STRENGTH

FRONT SUSPENSION (63-82)	6-4796	499.00
REAR SUSPENSION (63-79)	6-4799	650.00

### TRANSMISSION KITS - SEE PAGE 29-31

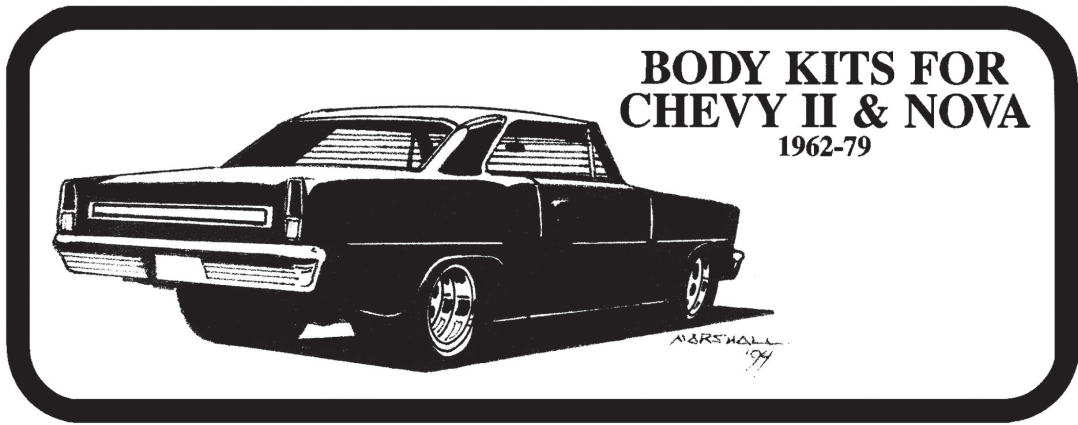

## KITS FOR 1962-1965 CHEVY II

**BODY KIT-** Every Body Kit includes component kits for Bumpers, Cross Member, Door Hinges & Latch, Door Jambs, Front Fenders, Front Seat Mounts, Hood Hinges & Latch & Catch, Inner Fender, Hood Stops & Shock Towers, Interior Trim Screw, Master Cylinder & Windshield Washer Tank, Radiator Support, Battery Box, & Horns, Tail Light, and Trunk Hinges & Latch & Catch. Available in 4 different bolt styles!

Contains one of each component kit

	HARD TOP:		SEDAN:		STATION WAGON:	
BUTTON AND SOCKET HEAD	#6-7087	\$310.50	# 6-7000	\$ 305.00	# 6-7083	\$380.00
HEX HEAD	6-7088	315.75	6-7001	315.75	6-7084	390.75
INDENTED HEX HEAD	6-7089	390.00	6-7002	390.00	6-7085	450.00
ORIGINAL STYLE	6-7090	435.00	6-7041	435.00	6-7086	499.00
INDENTED HEX WITH BLACK STAINLESS (WHERE APPROPRIATE)						
SIX POINT- HIGH STRENGTH - POLISHED	6-7093	815.50				

\*\* NOTE SIX POINT, INDENTED HEX, & ORIGINAL STYLE BOLTS ARE MADE IN USA \*\*

### ACCESSORY KITS (NOT INCLUDED IN THE BODY KIT)

**ENGINE KITS** - SEE PAGES 17-20

**REAR END COVER KITS** - SEE PAGE 31

**TRANSMISSION KITS** - SEE PAGE 29-31

**REAR DOORS KIT - FOR FOUR DOOR CARS**

**-THESE ARE INCLUDED IN THE STATION WAGON KITS! -**

FLAT SOCKET & PHILLIPS HEAD	# 6-7091	\$ 34.50
PHILLIPS FLAT & PAN HEAD	6-7092	32.50

## KITS FOR 1966-1967 NOVA

**BODY KIT-** Every Body Kit includes component kits for Bumpers, Door Hinges, Door Jambs & Sill, Front Fenders, Front Seat Mount, Grill, Headlight Bezels & Turn Signals, Hood Hinges & Latch & Catch, Inner Fenders, Interior Trim, Master Cylinder, Radiator Support, Seat Mount, Shock Towers, and Trunk Hinges. Comes in four different head styles including Original Style with black stainless where appropriate!

Contains one of each component kit

	HARD TOP:		SEDAN:		STATION WAGON:	
BUTTON AND SOCKET HEAD	# 6-7156	\$310.75	# 6-7100	\$ 300.75	# 6-7150	\$ 410.00
HEX HEAD	6-7157	315.50	6-7101	310.75	6-7151	415.75
INDENTED HEX HEAD	6-7158	399.00	6-7102	390.00	6-7152	475.00
ORIGINAL STYLE-INDENTED HEX	6-7159	405.00	6-7125	415.00	6-7153	499.00

WITH BLACK STAINLESS WHERE APPROPRIATE

\*\* NOTE INDENTED HEX, & ORIGINAL STYLE BOLTS ARE MADE IN USA \*\*

### ACCESSORY KITS (NOT INCLUDED IN THE BODY KIT)

**ENGINE KITS** - SEE PAGES 19-23

**REAR DOORS KIT - FOR FOUR DOOR CARS**

**-THESE ARE INCLUDED IN THE STATION WAGON KITS! -**

FLAT SOCKET & PHILLIPS HEAD	# 6-7154	\$ 42.00
PHILLIPS FLAT & PAN HEAD	6-7155	42.50

**REAR END COVER KITS** - SEE PAGE 31

**SUBFRAME MOUNT FOR HEIDT'S KIT**

SIX POINT - HIGH STRENGTH	6-6999	155.00
---------------------------	--------	--------

**SUBFRAME MOUNT FOR TCI KIT**

SIX POINT - HIGH STRENGTH	6-7099	235.00
---------------------------	--------	--------

**TRANSMISSION KITS** - SEE PAGE 29-31

**TOLL FREE ORDER LINE : 1-800-767-4781**





# KITS FOR 1968-1974 NOVA

**BODY KIT-** Each includes component kits for Body Mount, Bumpers, Door Hinges (68-72), Door Jambs, Fuel Tank, Grill (68-72), Headlight Bezels & Turn Signals, Hood Hinges & Latch & Catch, Interior Trim, License Plate & Bracket, Radiator Support, Inner & Outer Fenders, Battery Box, & Horn, Seat Mount (68-72), and Trunk Hinges, Latch & Catch. Comes in SIX different head styles including Original Style with black stainless where appropriate!

Contains one of each component kit

	1968-72		1973-74	
BUTTON AND SOCKET HEAD	# 6-7204	\$ 255.75	# 6-7250	\$ 220.00
HEX HEAD	6-7209	260.00	6-7251	225.00
INDENTED HEX HEAD	6-7216	350.00	6-7252	315.00
ORIGINAL STYLE- INDENTED HEX	6-7221	399.00	6-7253	350.00
WITH BLACK STAINLESS WHERE APPROPRIATE				
SIX POINT - HIGH STRENGTH - POLISHED	6-7248	815.00	6-7254	756.00
TWELVE POINT - HIGH STRENGTH - POLISHED	6-7249	855.50	6-7255	785.50

\*\* NOTE INDENTED HEX, ORIGINAL STYLE, 6 & 12 POINT BOLTS ARE MADE IN USA \*\*

## ACCESSORY KITS (NOT INCLUDED IN THE BODY KIT)

**CHASSIS KIT** - INCLUDES ALL KITS WITH AN \*  
BESIDE THE TITLE - HIGH STRENGTH  
SIX POINT - POLISHED # 6-1680 \$ 995.00  
TWELVE POINT - POLISHED 6-1684 1010.00

**SUSPENSION KITS\*** - HIGH STRENGTH BOLTS  
COMPLETE WITH COTTER PINS AND GREASE FITTINGS,

\*\*CASTLE NUTS NOT INCLUDED - SEE PAGE 130\*\*

FRONT SUSPENSION - SIX POINT 6-1681 \$ 455.00  
FRONT SUSPENSION - 12 POINT 6-1676 460.00  
REAR SUSPENSION - SIX POINT 6-1687 355.00  
REAR SUSPENSION - 12 POINT 6-1683 360.50

### STEERING BOX COVER & MOUNT KITS\*

SIX POINT - HIGH STRENGTH 6-1607 70.00  
TWELVE POINT - HIGH STRENGTH 6-1613 75.00

### TRANSMISSION CROSSMEMBER KITS\*

SIX POINT - HIGH STRENGTH 6-1768 39.50  
TWELVE POINT - HIGH STRENGTH 6-1771 42.00

### SUBFRAME MOUNT KIT\*

SIX POINT - HIGH STRENGTH 6-1699 \$ 175.00

### DOOR STRIKER BOLTS & WASHERS

SOCKET HEAD (PAIR) 6-8154 59.95

### ENGINE KITS - SEE PAGES 19-23

### ENGINE MOUNT KITS

SIX POINT - HIGH STRENGTH 6-1945 45.50  
TWELVE POINT - HIGH STRENGTH 6-1946 49.50

### REAR END COVER KITS - SEE PAGE 31

### TRANSMISSION KITS - SEE PAGE 29

# KITS FOR 1975-1979 NOVA

**BODY KIT-** Each includes component kits for Bumpers, Door Latches, Fenders, Front Body Mount, Grill & Headlight Bezel, Hood Hinges & Latch & Catch, Interior Trim, Master Cylinder, Radiator Support & Battery Box, Seat Mount, and Trunk Hinges, Latch & Catch. Comes in six different head styles including Original Style with black stainless where appropriate!

Contains one of each component kit

BUTTON AND SOCKET HEAD	# 6-7800	\$ 175.00
HEX HEAD	6-7801	180.50
INDENTED HEX HEAD	6-7802	250.00
ORIGINAL STYLE-INDENTED HEX	6-7803	275.00
WITH BLACK STAINLESS WHERE APPROPRIATE		
SIX POINT - HIGH STRENGTH - POLISHED	6-7804	475.00
TWELVE POINT - HIGH STRENGTH - POLISHED	6-7809	499.50

\*\* NOTE INDENTED HEX, ORIGINAL STYLE, 6 POINT & 12 POINT BOLTS ARE MADE IN USA \*\*

## ACCESSORY KITS (NOT INCLUDED IN THE BODY KIT)

**ENGINE KITS** - SEE PAGES 19-23

**SUSPENSION KITS-** COMPLETE WITH COTTER PINS  
AND GREASE FITTINGS, \*\*CASTLE NUTS NOT INCLUDED  
- SEE PAGE 3\*\*

FRONT SUSPENSION - HIGH STRENGTH #6-7839 \$ 499.50  
REAR SUSPENSION - HIGH STRENGTH 6-1688 335.50

**REAR END COVER KITS** - SEE PAGE 31

**TRANSMISSION KITS** - SEE PAGE 29

### DOOR STRIKER BOLTS & WASHERS

SOCKET HEAD (PAIR) # 6-8149 \$ 65.00

### SUB FRAME MOUNT KIT

SIX POINT - HIGH STRENGTH 6-1699 175.00



## BODY KITS FOR CHEVROLET TRUCKS

1941 - Early 1955

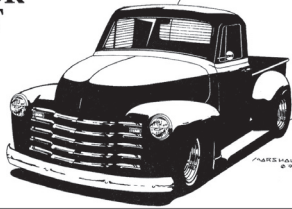

### BEDLESS BODY KITS

#### 1941 - EARLY 47:

BUTTON/FLAT SOCKET	# 6-9750	\$ 200.00
HEX HEAD & SLOTTED HEAD	6-9751	240.50

#### LATE 1947-51:

BUTTON/FLAT SOCKET HEAD	6-7381	225.00
HEX & PHILLIPS HEAD	6-7382	220.50
INDENTED HEX - ORIGINAL STYLE	6-7383	260.00

#### 1952-53:

BUTTON/FLAT SOCKET HEAD	6-7384	225.75
HEX & PHILLIPS HEAD	6-7385	220.75
INDENTED HEX - ORIGINAL STYLE	6-7386	260.00

#### 1954 - EARLY 55:

BUTTON/ FLAT SOCKET HEAD	6-7387	225.75
HEX & PHILLIPS HEAD	6-7388	230.50
INDENTED HEX - ORIGINAL STYLE	6-7389	299.00

### BODY KITS WITH A LONG BED

#### LATE 1947-51:

BUTTON/FLAT SOCKET HEAD	# 6-1170	\$ 420.00
HEX & PHILLIPS HEAD	6-1171	415.75
INDENTED HEX - ORIGINAL STYLE	6-1172	485.00

#### 1952-53:

BUTTON/FLAT SOCKET HEAD	6-1178	415.00
HEX & PHILLIPS HEAD	6-1179	410.75
INDENTED HEX - ORIGINAL STYLE	6-1180	465.00

#### 1954 - EARLY 55:

BUTTON/FLAT SOCKET HEAD	6-1186	415.00
HEX & PHILLIPS HEAD	6-1187	420.75
INDENTED HEX - ORIGINAL STYLE	6-1188	499.00

### BODY KITS WITH A SHORT BED

#### 1941 - EARLY 1947:

BUTTON/FLAT SOCKET HEAD	# 6-9749	\$ 350.75
HEX & SLOTTED HEAD	6-9752	360.00

#### LATE 1947-51:

BUTTON/FLAT SOCKET HEAD	6-1166	390.75
HEX & PHILLIPS HEAD	6-1167	385.00
INDENTED HEX - ORIGINAL STYLE	6-1168	475.00

#### 1952-53:

BUTTON/FLAT SOCKET HEAD	6-1174	385.00
HEX & PHILLIPS HEAD	6-1175	380.75
INDENTED HEX - ORIGINAL STYLE	6-1176	475.00

#### 1954 - EARLY 55:

BUTTON/FLAT SOCKET HEAD	6-1182	380.00
HEX & PHILLIPS HEAD	6-1183	390.50
INDENTED HEX - ORIGINAL STYLE	6-1184	490.00

### BODY KITS FOR PANEL TRUCKS

#### LATE 1947-51:

BUTTON/FLAT SOCKET HEAD	# 6-1546	\$ 465.00
HEX & PHILLIPS HEAD	6-1547	455.00
INDENTED HEX - ORIGINAL STYLE	6-1548	575.00

#### 1952-53:

BUTTON/FLAT SOCKET HEAD	6-1549	390.50
HEX & PHILLIPS HEAD	6-1550	380.00
INDENTED HEX - ORIGINAL STYLE	6-1551	445.00

#### 1954 - EARLY 55:

BUTTON/FLAT SOCKET HEAD	6-1574	400.75
HEX & PHILLIPS HEAD	6-1575	410.50
INDENTED HEX - ORIGINAL STYLE	6-1576	500.00

**BODY KIT-** Every Body Kit includes component kits for Front Bumper, Door Hinges, Door Latch & Catch, Fender to Firewall Brace Rods, Front & Inner Fenders, Grill & Gravel Pan, Headlight & Parking Lens, Hood Hinges, Hood Latch, Catch & Braces, Interior, Outside Mirror, Radiator Support, and Regulator & Relay.

Body kits with a bed also include kits for: Bed Mounts, Bed Strips, Front Bed Panel, Rear Fenders, Rear Bed Crossmember, Running Boards Tail Lights & Rear Posts and Tailgate Mounting.

### BED KITS - USED IN KITS LISTED WITH BEDS

#### 1941-EARLY 1947:

BUTTON HEAD	# 6-9764	\$ 175.00
HEX HEAD	6-9765	170.00

#### LATE 1947-51: **SHORT BED**      **LONG BED\***

BUTTON HEAD	6-1111	190.50	6-1154	220.50
HEX HEAD	6-1131	199.50	6-1155	215.50
INDENTED HEX	6-1140	235.00	6-1156	230.75

#### 1952-53: **SHORT BED**      **LONG BED\***

BUTTON HEAD	6-1177	180.50	6-1154	220.50
HEX HEAD	6-1189	185.50	6-1155	215.50
INDENTED HEX	6-1181	215.00	6-1156	230.00

#### '54-EARLY 55: **SHORT BED**      **LONG BED**

BUTTON HEAD	6-1157	185.00	6-1165	220.25
HEX HEAD	6-1161	190.00	6-1169	215.50
INDENTED HEX	6-1164	220.00	6-1173	250.00

\* LONG BED KIT IS THE SAME LATE 1947-53

**NOTE -** IF YOU WANT POLISHED BED BOLTS, ORDER A BEDLESS KIT AND ONE OF THE BED KITS LISTED BELOW:

### BED KITS - WITH POLISHED BED STRIP BOLTS & BED MOUNT BOLTS:

#### 1941-EARLY 1947:

BUTTON HEAD	6-9764P	235.00
HEX HEAD	6-9765P	230.00

#### LATE 1947-51: **SHORT BED**      **LONG BED\***

BUTTON HEAD	6-1111P	290.00	6-1154P	335.00
HEX HEAD	6-1131P	285.00	6-1155P	330.00
INDENTED HEX	6-1140P	325.00	6-1156P	380.00

#### 1952-53: **SHORT BED**      **LONG BED\***

BUTTON HEAD	6-1177P	265.00	6-1154P	335.00
HEX HEAD	6-1189P	260.00	6-1155P	330.00
INDENTED HEX	6-1181P	300.00	6-1156P	380.00

#### '54-EARLY 55: **SHORT BED**      **LONG BED**

BUTTON HEAD	6-1157P	285.00	6-1165P	330.00
HEX HEAD	6-1161P	280.00	6-1169P	325.00
INDENTED HEX	6-1164P	315.00	6-1173P	380.00

\*\* NOTE ORIGINAL STYLE INDENTED HEX BOLTS ARE MADE IN USA \*\*

### BODY KITS FOR SUBURBANS

#### LATE 1947-51:

BUTTON/FLAT SOCKET HEAD	# 6-6406	\$ 385.75
INDENTED HEX - ORIGINAL STYLE	6-6407	485.50

#### 1952-53:

BUTTON/FLAT SOCKET HEAD	6-6408	385.75
INDENTED HEX - ORIGINAL STYLE	6-6409	485.00

#### 1954 - EARLY 55:

BUTTON/FLAT SOCKET HEAD	6-6410	385.75
INDENTED HEX - ORIGINAL STYLE	6-6412	475.00

**CUSTOM MADE FLAT TOP  
CARRIAGE BOLTS FOR PANEL TRUCK  
BED STRIPS # 2-0799 \$5.75 EA  
(INCLUDED IN PANEL TRUCK KITS)**



**-SEE NEXT PAGE FOR ACCESSORY KITS-**

**ACCESSORY KITS (NOT INCLUDED IN THE BODY KIT)**

**CAB MOUNT KIT** - LATE 1947-EARLY 1955  
 \*INCLUDED IN THE KITS FOR PANEL TRUCKS & SUBURBANS\*  
 SIX POINT & HEX # 6-1199 \$ 52.50

**ENGINE KITS** - SEE PAGES 17-21

**FRONT BED PANEL ROD** - FOR LATE 1947-1953  
 51 1/4" LONG ROD WITH NUTS 6-1125 55.00

**REAR END COVER KITS** - SEE PAGE 31

**TRANSMISSION KITS** - SEE PAGE 29-31

**HOOD HINGE SHOULDER BOLTS** - L47-E55  
 BUTTON HEAD # 6-1132 \$ 121.00  
 HEX HEAD 6-1133 126.00

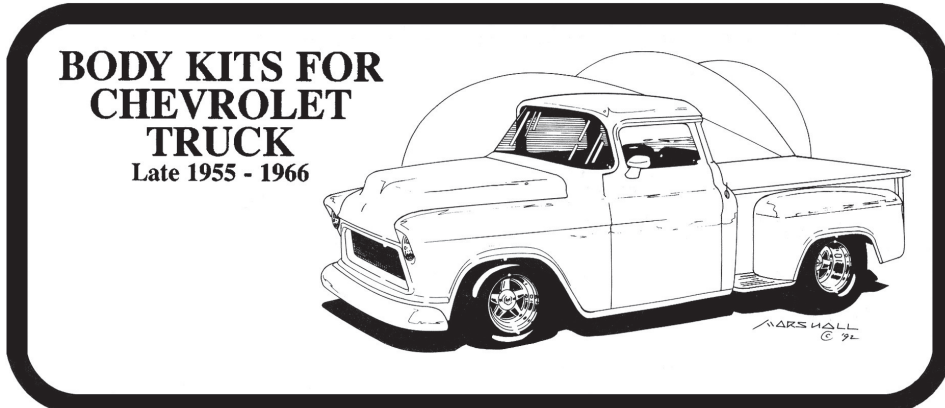

**BODY KITS FOR CHEVROLET TRUCK**  
 Late 1955 - 1966

**KITS FOR 1955-1959 CHEVY TRUCK**

**BODY KIT-** Every Body Kit includes component kits for Bumper, Door Hinges, Door Latch & Catch, Firewall, Cowl, & Battery Box, Front & Inner Fenders, Headlight & Front Lens, Hood Hinges, Hood Braces, Interior, Outside Mirrors, Seat Mount, Radiator Support, Hood Latch, Splash Pan and Front Mounts. Body kits with a bed also include all the appropriate bed component kits, see listings under bed kits on on the next page.

\*\* NOTE ORIGINAL STYLE INDENTED HEX BOLTS ARE MADE IN USA \*\*

**BEDLESS BODY KIT**

<b>LATE 1955 *</b>		
BUTTON/FLAT SOCKET HEAD	# 6-7321	\$ 235.00
HEX & PHILLIPS HEAD	6-7322	230.75
INDENTED HEX HEAD	6-7324	325.00
<b>1956-57</b>		
BUTTON/FLAT SOCKET HEAD	6-1235	240.75
HEX & PHILLIPS HEAD	6-1236	225.00
INDENTED HEX HEAD	6-1238	320.00
<b>1958-59</b>		
BUTTON/FLAT SOCKET HEAD	6-1291	250.50
HEX & PHILLIPS HEAD	6-1292	235.00
INDENTED HEX HEAD	6-1294	305.00

**BODY KITS WITH A CAMEO BED**

<b>LATE 1955 *</b>		
BUTTON/FLAT SOCKET HEAD	6-7349	530.50
INDENTED HEX & PHILLIPS HEAD	6-7353	740.00
<b>1956-57</b>		
BUTTON/FLAT SOCKET HEAD	6-7357	545.50
INDENTED HEX HEAD	6-7373	745.00
<b>1958</b>		
BUTTON/FLAT SOCKET HEAD	6-7378	550.50
INDENTED HEX HEAD	6-7379	730.00

**BODY KITS FOR PANEL TRUCKS**

<b>LATE 1955*</b>		
BUTTON HEAD	6-7685	465.75
HEX HEAD	6-7787	460.75
INDENTED HEX HEAD	6-7788	625.00
<b>1956-1957</b>		
BUTTON HEAD	6-7794	475.75
HEX HEAD	6-7795	455.00
INDENTED HEX HEAD	6-7796	620.00
<b>1958-1959</b>		
BUTTON HEAD	6-7797	475.75
HEX HEAD	6-7798	455.00
INDENTED HEX HEAD	6-7799	605.00

**\* NOTE: BEFORE ORDERING A LATE 1955 KIT, CHECK THE DOOR HINGE AND RADIATOR TO FRAME BOLTS - LATE 1955 TRUCKS USE CARRIAGE BOLTS ON THESE ITEMS, IF YOUR TRUCK HAS HEX HEAD BOLTS, ORDER A 56-57 KIT**

**BODY & LONG STEPSIDE BED KITS**

<b>LATE 1955 *</b>		
BUTTON/FLAT SOCKET HEAD	# 6-7327	\$ 455.00
HEX & PHILLIPS HEAD	6-7328	450.00
INDENTED HEX HEAD	6-7329	575.00
<b>1956-57</b>		
BUTTON/FLAT SOCKET HEAD	6-1894	455.00
HEX & PHILLIPS HEAD	6-1895	440.50
INDENTED HEX HEAD	6-1896	579.00
<b>1958-59</b>		
BUTTON/FLAT SOCKET HEAD	6-1884	465.00
HEX & PHILLIPS HEAD	6-1885	455.00
INDENTED HEX HEAD	6-1886	565.00

**BODY & SHORT STEPSIDE BED KITS**

<b>LATE 1955 *</b>		
BUTTON/FLAT SOCKET HEAD	6-7330	445.50
HEX & PHILLIPS HEAD	6-7331	430.00
INDENTED HEX HEAD	6-7332	565.00
<b>1956-57</b>		
BUTTON/FLAT SOCKET HEAD	6-1890	445.00
HEX & PHILLIPS HEAD	6-1891	430.50
INDENTED HEX HEAD	6-1892	567.00
<b>1958-59</b>		
BUTTON/FLAT SOCKET HEAD	6-1880	450.00
HEX & PHILLIPS HEAD	6-1881	440.00
INDENTED HEX HEAD	6-1882	555.00

**1958-59 BODY & FLEETSIDE BED KITS**

BUTTON/FLAT SOCKET HEAD	6-7346	445.00
HEX & PHILLIPS HEAD	6-7347	425.50
INDENTED HEX HEAD	6-7348	545.00

**50 BED KIT-** Every Bed Kit includes component kits for Bed Mounts, Bed Strips & Angles, Front Bed Panel, Rear Bumper, Tail Gate, and Tail Lights. Cameo Bed kits also have Rear Fender Braces, Rear Fender Front Panels, Rear Panel & Tail Gate, Spare Tire Carrier & Cover, and Top Rails kits. Fleetside Bed kits also contain kits for Inner Fenders & Side Angles and Rear Fender Braces. Stepside beds also have kits for License Plate & Bracket, Side Steps, and Rear Fenders. **\*\* NOTE ORIGINAL STYLE INDENTED HEX BOLTS ARE MADE IN USA \*\***  
**-COMPLETE BED KITS CONTAIN UNPOLISHED BOLTS UNLESS STATED OTHERWISE-**

**CAMEO BED KITS**

BUTTON/FLAT SOCKET HEAD # 6-1250 \$ 325.00  
 INDENTED HEX HEAD - ORIGINAL STYLE 6-1273 425.00

**BEDS WITH POLISHED BED FLOOR BOLTS:**

BUTTON/FLAT SOCKET HEAD 6-1250P 435.00  
 INDENTED HEX HEAD - ORIGINAL STYLE 6-1273P 485.00

**FLEETSIDE BED KITS (1958-59)**

BUTTON & CARRIAGE HEAD 6-7342 220.75  
 HEX & CARRIAGE HEAD 6-7343 215.00  
 INDENTED HEX & CARRIAGE HEAD 6-7344 260.00

**BEDS WITH POLISHED BED FLOOR BOLTS:**

BUTTON & CARRIAGE HEAD 6-7342P 350.75  
 HEX & CARRIAGE HEAD 6-7343P 345.00  
 INDENTED HEX & CARRIAGE HEAD 6-7344P 395.00

**LONG STEPSIDE BED KITS**

BUTTON/FLAT SOCKET HEAD # 6-1248 \$240.50  
 HEX & CARRIAGE HEAD 6-1263 235.75  
 INDENTED HEX & CARRIAGE HEAD 6-1249 280.00

**BEDS WITH POLISHED BED FLOOR BOLTS:**

BUTTON/FLAT SOCKET HEAD 6-1248P 345.50  
 HEX & CARRIAGE HEAD 6-1263P 335.75  
 INDENTED HEX & CARRIAGE HEAD 6-1249P 385.00

**SHORT STEPSIDE BED KITS**

BUTTON & CARRIAGE HEAD 6-1241 225.75  
 HEX & CARRIAGE HEAD 6-1246 220.50  
 INDENTED HEX & CARRIAGE HEAD 6-1247 270.00

**BEDS WITH POLISHED BED FLOOR BOLTS:**

BUTTON & CARRIAGE HEAD 6-1241P 325.50  
 HEX & CARRIAGE HEAD 6-1246P 320.75  
 INDENTED HEX & CARRIAGE HEAD 6-1247P 370.00

**ACCESSORY KITS (NOT INCLUDED IN THE BODY & BED KITS)**

**CAB MOUNT BOLT KIT - INCLUDED IN PANEL TRUCK KIT**

HEX HEAD # 6-7398 \$ 40.00

**HIDDEN DOOR HINGE BOLTS KIT - (1956-59)**

HEX (12 BOLTS) # 6-4684 13.00

**EXTRA BED MOUNT HARDWARE**

- FOR TRUCKS WITH MORE THAN 8 BED MOUNT BOLTS

- INCLUDES (2) BOLTS, NUTS, LOCKS & WASHERS

CARRIAGE HEAD 6-1298 15.00  
 POLISHED CARRIAGE HEAD 6-1298P 19.00

**HOOD HINGE RIVET REPLACEMENT KIT:**

(10) SHOULDERED RIVETS & THIN LOCK NUTS 6-7767 235.00

**INNER WINDOW TRIM - FOR SUBURBAN**

PHILLIPS OVAL 6-1293 10.75

**ORIGINAL TYPE REAR COVER KITS**

HEX HEAD (3/8 -24) 6-5571 12.00

-SEE PAGE 33 FOR DANA REAR COVERS

**SPARE TIRE COVER BOLTS FOR CAMEO -THESE ARE INCLUDED IN THE BED KITS! -**

BUTTON HEAD (SET OF 2) 6-7737 36.00  
 HEX FLANGED POLISHED (2) 6-1212 40.00

**KIT FOR ORIGINAL STYLE CHASSIS INCLUDES STEERING BOX KIT**

HEX HEAD & SIX POINT 6-7403 225.00

**STEERING BOX KIT**

HEX HEAD 6-7395 26.00

**KITS FOR 1960-1966 CHEVY TRUCKS**

**BODY KIT-** Every Body Kit includes component kits for Bumper, Cowl, Door Hinges, Door Jambs, Sills, & Latches, Firewall, Master Cylinder, & Steering Column, Front & Inner Fenders, Headlight, & Front Signals, Hood Braces, Hood Hinges, Hood Latch, Interior, Radiator Support, & Battery Box, Outside Mirrors, and Seat Mount. Body kits with a bed also include all the appropriate bed component kits, see listings under bed kits on the next page. **\*\* NOTE INDENTED HEX, & ORIGINAL STYLE BOLTS ARE MADE IN USA \*\***

**BEDLESS BODY KITS**

BUTTON & SOCKET HEAD # 6-1340 \$ 250.00  
 HEX HEAD 6-1376 265.75  
 INDENTED HEX HEAD 6-1377 405.00  
 ORIGINAL STYLE-INDENTED HEX 6-1580 499.00  
 WITH BLACK STAINLESS WHERE APPROPRIATE

**\*\*IF YOU HAVE A PANEL OR FLAT BED TRUCK, ORDER A BEDLESS BODY KIT - IF YOU WANT POLISHED BED FLOOR BOLTS, ORDER A BEDLESS KIT & A BED KIT WITH POLISHED BED FLOOR BOLTS (ON NEXT PAGE)**

**BODY & LONG FLEETSIDE BED KITS**

BUTTON & SOCKET HEAD 6-7370 465.75  
 HEX HEAD 6-7371 465.50  
 INDENTED HEX HEAD 6-7372 660.00  
 ORIGINAL STYLE-INDENTED HEX 6-1581 755.00  
 WITH BLACK STAINLESS WHERE APPROPRIATE

**BODY & SHORT FLEETSIDE BED KITS**

BUTTON & SOCKET HEAD # 6-7354 \$ 450.00  
 HEX HEAD 6-7355 460.00  
 INDENTED HEX HEAD 6-7356 620.00  
 ORIGINAL STYLE-INDENTED HEX 6-1583 715.00  
 WITH BLACK STAINLESS WHERE APPROPRIATE

**BODY & LONG STEPSIDE BED KITS**

BUTTON & SOCKET HEAD 6-1825 460.75  
 HEX HEAD 6-1826 475.00  
 INDENTED HEX HEAD 6-1827 655.00  
 ORIGINAL STYLE- INDENTED HEX 6-1582 745.00  
 WITH BLACK STAINLESS WHERE APPROPRIATE

**BODY & SHORT STEPSIDE BED KITS**

BUTTON & SOCKET HEAD 6-1821 450.00  
 HEX HEAD 6-1822 460.00  
 INDENTED HEX HEAD 6-1823 650.00  
 ORIGINAL STYLE-INDENTED HEX 6-1584 740.00  
 WITH BLACK STAINLESS WHERE APPROPRIATE



# BED KITS FOR 1960-1966 CHEVY TRUCKS

Each Complete Bed Kit includes component kits for Bed Mounts, Bed Strips & Angles, Fenders, Front Bed Panel, Rear Bumper, Tail Lights, and Tail Gate. Fleetside bed kits also include Inner Fender & Side Angles, and Rear Fender Braces kits. Stepside bed kits also include kits for Side Steps, and Rear Fenders.

## LONG FLEETSIDE BED KITS

BUTTON & CARRIAGE HEAD	# 6-7375	\$ 240.00
HEX & PHILLIPS HEAD	6-7376	225.00
INDENTED HEX & PHILLIPS HEAD	6-7377	280.00

## BEDS WITH POLISHED BED FLOOR BOLTS:

BUTTON & CARRIAGE HEAD	6-7375P	360.00
HEX & PHILLIPS HEAD	6-7376P	355.00
INDENTED HEX & PHILLIPS HEAD	6-7377P	390.00

## LONG STEPSIDE BED KITS

BUTTON & CARRIAGE HEAD	6-1834	235.75
HEX & PHILLIPS HEAD	6-1835	230.50
INDENTED HEX & PHILLIPS HEAD	6-1836	270.00

## BEDS WITH POLISHED BED FLOOR BOLTS:

BUTTON & CARRIAGE HEAD	6-1834P	340.50
HEX & PHILLIPS HEAD	6-1835P	335.00
INDENTED HEX & PHILLIPS HEAD	6-1836P	375.00

## SHORT FLEETSIDE BED KITS

BUTTON & CARRIAGE HEAD	# 6-7366	\$ 225.00
HEX & PHILLIPS HEAD	6-7367	220.75
INDENTED HEX & PHILLIPS HEAD	6-7368	260.00

## BEDS WITH POLISHED BED FLOOR BOLTS:

BUTTON & CARRIAGE HEAD	6-7366P	340.00
HEX & PHILLIPS HEAD	6-7367P	340.00
INDENTED HEX & PHILLIPS HEAD	6-7368P	380.00

## SHORT STEPSIDE BED KITS

BUTTON & CARRIAGE HEAD	6-1337	225.50
HEX & PHILLIPS HEAD	6-1338	220.75
INDENTED HEX & PHILLIPS HEAD	6-1339	265.00

## BEDS WITH POLISHED BED FLOOR BOLTS:

BUTTON & CARRIAGE HEAD	6-1337P	310.50
HEX & PHILLIPS HEAD	6-1338P	305.75
INDENTED HEX & PHILLIPS HEAD	6-1339P	345.00

## ACCESSORY KITS (NOT INCLUDED IN THE BODY & BED KITS)

### CAB MOUNT KIT

HEX - PICKUP	# 6-7467	\$ 95.00
CARRIAGE/HEX - PANEL	6-7396	115.00

### FRONT BODY MOUNT KITS

CARRIAGE HEAD	# 6-7399	\$ 50.00
---------------	----------	----------

### ENGINE FASTENER KITS - SEE PAGE 17-21

### STEERING BOX KIT - MANUAL BOX

SIX POINT -HIGH STRENGTH	6-7369	55.00
--------------------------	--------	-------

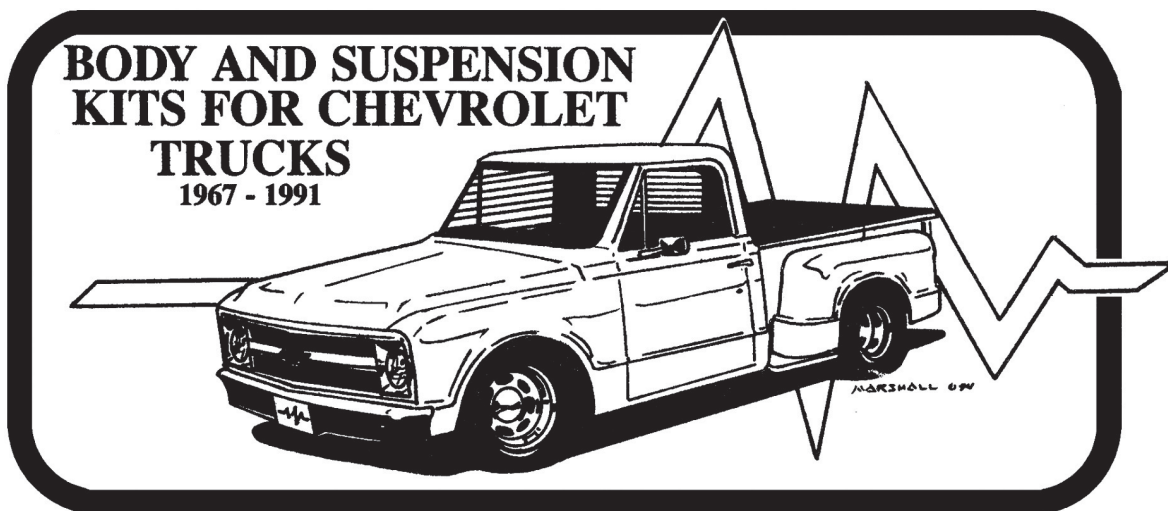

## KITS FOR 1967-1972 CHEVY TRUCKS INCLUDING BLAZERS & SUBURBANS

Each Body Kit includes component kits for Battery Box, Bumper, Cowl Cover, Front & Inner Fenders, Door Hinges, Door Jambs & Sills, Door Latches, Headlight Bezels, Front Lens & Side Marker Light, Hood Hinges, Hood Latch, Interior, Outside Mirrors, Radiator Support, and Seat Mounts. Blazer & Suburban Kits include kits for Rear Bumper, Rear Wheel Tubs, Tail Lights, Third door kit for Suburbans, & Top to Body Mount Bolts for Blazer. Body Kits with Beds also include all appropriate bed component kits listed on the next page.

**SEE NEXT PAGE FOR BODY & CHASSIS KITS!**



TOLL FREE ORDER LINE : 1-800-767-4781

**BODY KITS FOR 1967-1972 CHEVY TRUCKS****BEDLESS BODY KITS**

BUTTON & FLAT SOCKET HEAD	# 6-1388	\$ 260.00
HEX & PHILLIPS HEAD	6-1389	250.75
INDENTED HEX HEAD	6-1390	350.00
ORIGINAL STYLE-INDENTED HEX	6-1393	385.00
WITH BLACK STAINLESS WHERE APPROPRIATE		
SIX POINT - POLISHED	9-9750	789.50
TWELVE POINT - POLISHED	9-9751	799.50

**BODY & FLEETSIDE BED KITS - FOR TRUCKS**

WITH METAL FLOOR BEDS

BUTTON & FLAT SOCKET HEAD	6-1866	415.50
HEX HEAD	6-1867	410.00
INDENTED HEX HEAD	6-1868	550.00
ORIGINAL STYLE-INDENTED HEX	6-7435	585.00
WITH BLACK STAINLESS WHERE APPROPRIATE		
SIX POINT & PLAIN CARRIAGE	9-9774	1195.00
TWELVE POINT & CARRIAGE	9-9775	1225.50

**BODY KITS FOR BLAZER - 1969-72**

BUTTON HEAD	6-1372	375.00
HEX HEAD	6-1373	355.75
INDENTED HEX HEAD	6-1374	490.00
ORIGINAL STYLE - INDENTED HEX	6-1424	525.00
WITH BLACK STAINLESS WHERE APPROPRIATE		

**-IF YOU NEED FASTENERS FOR A PANEL OR FLAT BED TRUCK ORDER A BEDLESS BODY KIT-****BED KITS**

- Every Bed Kit includes component kits for Bed Mounts, Bed Strips (wood floor beds only) & Angles, Front Bed Panel, Rear Bumper, Tail Lights, and Tail Gate. Fleetside Bed kits also contain kits for: Inner Fenders to Bed & Side angles, Rear Cross Member, and Rear Fender Braces & Inner Fenders to Fenders. Stepside Bed kits also contain kits for Rear Fenders, and Side Steps.

**-BED KITS CONTAIN UNPOLISHED BOLTS UNLESS STATED OTHERWISE-****FLEETSIDE BED KITS - ALL METAL BED**

BUTTON & CARRIAGE HEAD	# 6-1384	\$ 180.75
HEX & CARRIAGE HEAD	6-1385	185.75
INDENTED HEX HEAD	6-1386	225.75
SIX POINT & CARRIAGE	9-9786	399.00
TWELVE POINT & CARRIAGE	9-9787	415.50

**KITS WITH POLISHED BED BOLTS:**

BUTTON & CARRIAGE HEAD	6-1384P	240.00
HEX & CARRIAGE HEAD	6-1385P	245.50
INDENTED HEX & CARRIAGE HEAD	6-1386P	280.00
SIX POINT & CARRIAGE	9-9786P	435.00

**FLEETSIDE BED KITS - WOOD FLOOR BED**

BUTTON & CARRIAGE HEAD	6-7754	265.50
HEX & CARRIAGE HEAD	6-7755	270.50
INDENTED HEX & CARRIAGE HEAD	6-7756	350.00
SIX POINT & CARRIAGE	9-9784	151.00

**KITS WITH POLISHED BED BOLTS:**

BUTTON & CARRIAGE HEAD	6-7754P	400.50
HEX & CARRIAGE HEAD	6-7755P	405.50
INDENTED HEX & CARRIAGE HEAD	6-7756P	465.00
SIX POINT & CARRIAGE - POLISHED	9-9784P	630.50

**ACCESSORY KITS (NOT INCLUDED IN THE BODY & BED KITS)**

<b>CAB MOUNT KITS - 1/2 TON:</b>	# 6-7467	\$ 75.00
- FOR BLAZER:	6-1346	135.00
- FOR SUBURBAN:	6-1441	155.00

**ENGINE FASTENER KITS - SEE PAGES 17-21****ENGINE MOUNTS TO BRACKETS & BRACKETS TO FRAME KIT**

SIX POINT -HIGH STRENGTH	6-7725	56.00
TWELVE POINT - HIGH STRENGTH	6-1421	59.00

**FRONT BODY MOUNT KITS**

-CORE SUPPORT TO FRAME		
CARRIAGE HEAD	6-7743	30.75

**REAR END COVER KITS - SEE PAGE 31****TRANSMISSION KITS -SEE PAGE 29****BODY & LONG STEPSIDE BED KITS**

BUTTON & SOCKET HEAD	# 6-1862	\$ 490.00
HEX & CARRIAGE HEAD	6-1863	480.50
INDENTED HEX HEAD	6-1864	645.00
ORIGINAL STYLE-INDENTED HEX	6-7434	685.00
WITH BLACK STAINLESS WHERE APPROPRIATE		
SIX POINT - POLISHED	9-9776	1199.50

**BODY & SHORT STEPSIDE BED KITS**

BUTTON & SOCKET HEAD	6-7726	475.75
HEX & CARRIAGE HEAD	6-1859	465.75
INDENTED HEX HEAD	6-1860	600.00
ORIGINAL STYLE-INDENTED HEX	6-7433	640.00
WITH BLACK STAINLESS WHERE APPROPRIATE		
SIX POINT - POLISHED	9-9778	1165.00

**BODY KITS FOR SUBURBANS**

BUTTON HEAD	6-1442	410.00
HEX HEAD	6-1443	400.50
INDENTED HEX HEAD	6-1444	539.00
ORIGINAL STYLE - INDENTED HEX	6-1445	565.00
WITH BLACK STAINLESS WHERE APPROPRIATE		

**LONG STEPSIDE BED KITS**

BUTTON & CARRIAGE HEAD	# 6-1874	\$ 255.00
HEX & CARRIAGE HEAD	6-1875	255.75
INDENTED HEX & CARRIAGE HEAD	6-1876	300.00
SIX POINT & CARRIAGE	9-9782	399.50

**KITS WITH POLISHED BED BOLTS:**

BUTTON & CARRIAGE HEAD	6-1874P	355.00
HEX & CARRIAGE HEAD	6-1875P	355.75
INDENTED HEX & CARRIAGE HEAD	6-1876P	399.00
SIX POINT & CARRIAGE	9-9782P	530.00

**SHORT STEPSIDE BED KITS**

BUTTON & CARRIAGE HEAD	6-1870	240.00
HEX & CARRIAGE HEAD	6-1871	245.00
INDENTED HEX & CARRIAGE HEAD	6-1873	258.00
SIX POINT & CARRIAGE	9-9780	365.00

**KITS WITH POLISHED BED BOLTS:**

BUTTON & CARRIAGE HEAD	6-1870P	325.00
HEX & CARRIAGE HEAD	6-1871P	325.00
INDENTED HEX & CARRIAGE HEAD	6-1873P	350.00
SIX POINT & CARRIAGE	9-9780P	475.00

**STEERING BOX MOUNT & COVER KITS****-MANUAL STEERING BOX**

SIX POINT -HIGH STRENGTH	6-7752	43.50
--------------------------	--------	-------

**-POWER STEERING BOX**

SIX POINT -HIGH STRENGTH	6-7753	57.00
TWELVE POINT-HIGH STRENGTH	6-7769	59.00

**SUSPENSION KITS - WITH HIGH STRENGTH****U-BOLTS! GREASE FITTINGS & COTTER PINS INCLUDED,****\*CASTLE NUTS NOT INCLUDED - SEE PAGE 130\*\*****- FOR 2 WHEEL DRIVE TRUCKS ONLY**

FRONT: SIX POINT - 1/2 & 3/4 TON	6-1309	440.50
FRONT: TWELVE POINT - 1/2 TON	6-1329	450.50

**TRANSMISSION CROSSMEMBER KIT**

SIX POINT -HIGH STRENGTH	6-7739	58.50
TWELVE POINT-HIGH STRENGTH	6-7695	68.50

# KITS FOR 1973-1987 CHEVY C/K TRUCKS

**BODY KIT-** Every Body kit includes component kits for Battery Box, Cowl, Door Hinges, Door Jambs, Interior, Front Bumpers, Front & Inner Fender, Hood Hinges, Hood Latch & Catch, Radiator Support, & Shroud ('81-'87 only), Master Cylinder, Radiator Support, Battery Box, & Hood Latch ('73-'80 only), and Seat Mounts.  
**\*IF YOU NEED FASTENERS FOR A BLAZER OR SUBURBAN (UP TO '91) ORDER A BEDLESS BODY KIT\***

## BEDLESS BODY KITS

1973-1980

BUTTON & FLAT SOCKET HEAD	# 6-1523	\$ 255.00
HEX & PHILLIPS HEAD	6-1524	280.50
INDENTED HEX HEAD	6-1525	335.00
ORIGINAL STYLE-INDENTED HEX	6-1526	370.00

WITH BLACK STAINLESS WHERE APPROPRIATE

1981-1987

BUTTON & FLAT SOCKET HEAD	6-1527	215.75
HEX & PHILLIPS HEAD	6-1528	220.50
INDENTED HEX	6-1529	325.00
ORIGINAL STYLE - INDENTED HEX	6-1530	345.00

WITH BLACK STAINLESS WHERE APPROPRIATE

## BODY & FLEETSIDE BED KITS

1973-1980

BUTTON & FLAT SOCKET HEAD	6-7458	380.50
HEX HEAD	6-7459	415.75
INDENTED HEX HEAD	6-7460	515.00
ORIGINAL STYLE-INDENTED HEX	6-7473	550.00

WITH BLACK STAINLESS WHERE APPROPRIATE

1981-1987

BUTTON & FLAT SOCKET HEAD	6-1474	345.50
HEX HEAD	6-1475	355.00
INDENTED HEX HEAD	6-1476	510.00
ORIGINAL STYLE-INDENTED HEX	6-1477	540.00

WITH BLACK STAINLESS WHERE APPROPRIATE

## BODY & LONG STEPSIDE BED KITS

1973-1980

BUTTON & SOCKET HEAD	# 6-7454	\$ 465.00
HEX HEAD	6-7455	485.75
INDENTED HEX HEAD	6-7456	575.00
ORIGINAL STYLE-INDENTED HEX	6-7472	605.00

WITH BLACK STAINLESS WHERE APPROPRIATE

1981-1987

BUTTON & SOCKET HEAD	6-1519	425.75
HEX HEAD	6-1520	425.75
ORIGINAL STYLE-INDENTED HEX	6-1521	565.00
ORIGINAL INDENTED HEX	6-1522	595.00

WITH BLACK STAINLESS WHERE APPROPRIATE

## BODY & SHORT STEPSIDE BED KITS

1973-1980

BUTTON & SOCKET HEAD	6-7450	445.75
HEX HEAD	6-7451	470.75
INDENTED HEX HEAD	6-7452	570.00
ORIGINAL STYLE-INDENTED HEX	6-7471	605.00

WITH BLACK STAINLESS WHERE APPROPRIATE

1981-1987

BUTTON & SOCKET HEAD	6-1469	415.00
HEX HEAD	6-1470	415.00
INDENTED HEX HEAD	6-1471	565.00
ORIGINAL STYLE-INDENTED HEX	6-1472	595.00

WITH BLACK STAINLESS WHERE APPROPRIATE

**\*\* NOTE INDENTED HEX, & ORIGINAL STYLE BOLTS ARE MADE IN USA \*\***

**BED KIT-** Every Complete Bed Kit includes component kits for Bed Mounts, Front Bed Panel, Rear Bumper, Tail Lights, and Tail Gate. Fleetside Bed kits also include kits for: Inner Fender & Fender Braces, and Rear Cross Member. Stepside Bed kits also include kits for; Rear Fenders, Bed Strips, and Side Steps.  
 -COMPLETE BED KITS HAVE UNPOLISHED BOLTS UNLESS STATED OTHERWISE-

## FLEETSIDE BED KITS

BUTTON & CARRIAGE HEAD	6-7474	\$ 155.00
HEX & CARRIAGE HEAD	6-7475	160.50
INDENTED HEX & CARRIAGE HEAD	6-7476	220.00

### KITS WITH POLISHED BED MOUNT BOLTS:

BUTTON & CARRIAGE HEAD	6-7474P	170.00
HEX & CARRIAGE HEAD	6-7475P	170.75
INDENTED HEX & CARRIAGE HEAD	6-7476P	240.00

## LONG STEPSIDE BED KITS

BUTTON & CARRIAGE HEAD	6-7488	235.00
HEX & CARRIAGE HEAD	6-7489	230.50
INDENTED HEX & CARRIAGE HEAD	6-7491	275.00

### KITS WITH POLISHED BED BOLTS:

BUTTON & CARRIAGE HEAD	6-7488P	335.00
HEX & CARRIAGE HEAD	6-7489P	335.50
INDENTED HEX & CARRIAGE HEAD	6-7491P	380.00

## SHORT STEPSIDE BED KITS

BUTTON & CARRIAGE HEAD	# 6-7484	\$ 220.00
HEX & CARRIAGE HEAD	6-7485	220.50
INDENTED HEX & CARRIAGE HEAD	6-7487	275.00

### KITS WITH POLISHED BED BOLTS:

BUTTON & CARRIAGE HEAD	6-7484P	310.00
HEX & CARRIAGE HEAD	6-7485P	310.50
INDENTED HEX & CARRIAGE HEAD	6-7487P	365.00

**NOTE - ALL BED KITS HAVE 4" LONG CARRIAGE BOLTS IN THE BED MOUNT KIT. SOME TRUCKS USE (2) 12" LONG CARRIAGE BOLTS FOR THE FRONT BED MOUNT, IF YOU NEED THESE ORDER PART #2-0782 - \$11.95 EACH.**

**-SEE NEXT PAGE FOR ACCESSORY KITS-**



## ACCESSORY KITS FOR 1973-1987 CHEVY C/K TRUCKS

(NOT INCLUDED IN THE BODY AND BED KITS)

**BACKING PLATE BRAKE STUDS** - (1) PAIR WITH  
SPECIAL NUTS HIGH STRENGTH # 9-7700 \$ 101.25

### **BRAKE LINES KITS**

BUTTON HEAD 6-7764 14.00  
INDENTED HEX HEAD 6-7765 40.00

### **CAB MOUNT KITS**

1973-1980  
HEX HEAD 6-7748 50.00  
SOCKET HEAD 6-7749 60.00  
1981-1987  
HEX HEAD 6-7750 19.25  
SOCKET HEAD 6-7751 26.50

### **FRONT BODY MOUNT KITS** - CORE SUPPORT TO FRAME

1973-1980  
HEX HEAD 6-7744 30.00  
SOCKET HEAD 6-7745 35.00  
1981-1987  
HEX HEAD 6-7746 13.00  
SOCKET HEAD 6-7747 17.00

**DOOR STRIKERS KIT** - SOCKET HEAD SHOULDER  
BOLTS WITH WASHERS - HIGH STRENGTH 17-4PH -  
ELIMINATES PLASTIC SLEEVE 6-7766 95.50

**ENGINE FASTENER KITS** - SEE PAGES 17-23

### **ENGINE MOUNTS TO BRACKETS & BRACKETS TO FRAME KIT**

SIX POINT -HIGH STRENGTH # 6-7761 \$ 75.00

**REAR END COVER KITS** -SEE PAGE 31

### **SHOCK STUD KIT**

FRONT - HIGH STRENGTH 9-7701 75.00  
REAR - HIGH STRENGTH 9-7702 78.50

### **STEERING BOX MOUNT & COVER KIT**

-MANUAL STEERING BOX  
SIX POINT -HIGH STRENGTH 6-7752 43.50  
-POWER STEERING BOX  
SIX POINT -HIGH STRENGTH 6-7753 57.00  
TWELVE POINT -HIGH STRENGTH 6-7769 59.00

**SUSPENSION KITS** - FOR 1/2 & 3/4 TON TRUCKS  
INCLUDES HIGH STRENGTH BOLTS & U-BOLTS!

\*\*CASTLE NUTS NOT INCLUDED - SEE PAGE 130\*

### **FRONT SUSPENSIONS:**

2WD: SIX POINT -HIGH STRENGTH 6-7760 665.00

4WD: SIX POINT -HIGH STRENGTH 6-7762 545.50

### **REAR SUSPENSIONS:**

ALL: SIX POINT -HIGH STRENGTH 6-7763 565.50

**TRANSMISSION KITS** - SEE PAGE 29-30

## KITS FOR 1988 -1998 CHEVY TRUCKS

### **BATTERY BOX KITS**

BUTTON HEAD # 6-1535 \$ 6.00  
HEX HEAD 6-1536 5.75

### **BED MOUNT KITS** - FLEETSIDE - A4-80

HEX HEAD 6-1541 45.00  
SOCKET HEAD 6-1542 50.00

### **FRONT BODY MOUNT KIT**

HEX HEAD 5-5206 25.00  
SOCKET HEAD 5-5207 29.00

### **FRONT & INNER FENDERS KITS**

BUTTON HEAD 6-1531 21.50  
HEX HEAD 6-1532 18.50

### **MASTER CYLINDER KIT**

HEX NUTS 6-1506 4.00

**DOOR STRIKERS KIT** - SOCKET HEAD SHOULDER  
BOLTS WITH WASHERS 6-8149 65.00

**ENGINE FASTENER KITS** - SEE PAGES 17-23

**TRANSMISSION KITS** - SEE PAGE 29-30

### **HOOD LATCH KITS**

BUTTON HEAD # 6-1504 \$ 8.75  
HEX HEAD 6-1505 8.25

### **HOOD HINGES KITS**

BUTTON HEAD 6-1501 8.75  
HEX HEAD 6-1502 8.50

### **RADIATOR SUPPORT KITS**

BUTTON HEAD 6-1533 10.75  
HEX HEAD 6-1534 10.00

### **TAIL GATE KIT**

BUTTON & FLAT SOCKET 6-1510 14.00

**REAR END COVER KITS** -SEE PAGE 31

**SERPENTINE BELT KITS** - SEE PAGE 22

**T . O . T . A . L . L . Y**  
**STAINLESS**



# KITS FOR CHEVY S-10 / GMC S-15 & SYCLONE

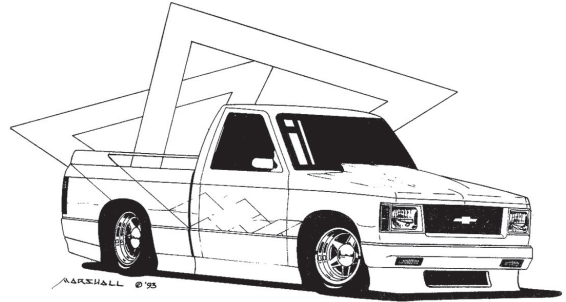

**BODY KIT-** Every Body kit includes component kits for Battery Box, Bed Mount, Body Mount(Standard Cab), Door Latch, Door Sills, Front & Inner Fenders, Hood Hinges, Hood Latch, Catch & Prop Rod, Heater Blower, Interior, Master Cylinder & Valve, Seat Mount, Radiator Support & Fan Shroud, Rear Fender, Tail Gate Hinge, Latch & Catch, and Windshield Washer Fluid Tank. Kits for Syclones also include component kits for mounting the Intercooler, Gas Tank and Rear Bumper.

## FOR S-10 / GMC S-15: - (1982 - 93)

BUTTON, SOCKET & FLAT SOCKET HEAD	# 5-0731	\$ 225.00
HEX & PHILLIPS HEAD	5-0732	225.00
SOCKET & FLAT SOCKET HEAD	5-0733	260.50

## SYCLONE:

BUTTON, SOCKET & FLAT SOCKET HEAD	# 5-2700	\$ 280.75
HEX & PHILLIPS HEAD	5-2702	285.00
SOCKET & FLAT SOCKET HEAD	5-2703	310.50
6 POINT -HIGH STRENGTH - POLISHED	5-2798	999.50

## ACCESSORY KITS (NOT INCLUDED IN THE BODY KIT)

### ADD ON INTERIOR KITS - (1998 -82)

-FOR EXTENDED CABS

PLAIN FINISH	# 5-0748	\$ 15.00
BLACK FINISH	5-0749	30.00

### DOOR STRIKER BOLTS & WASHERS - HIGH STRENGTH 17-4 PH STAINLESS FOR LONGER WEAR - MADE IN USA

SOCKET HEAD (PAIR)	6-8149	65.00
--------------------	--------	-------



### CHASSIS KITS - S10/S15: INCLUDES FRONT & REAR SUSPENSION & STEERING BOX

SIX POINT - HIGH STRENGTH		
1982-1993:	# 5-2200	\$ 1050.00
1994-2004:	5-2202	1150.50

### CHASSIS KITS - SYCLONE: INCLUDES FRONT & REAR SUSPENSION, STEERING BOX, ENGINE MOUNTS, DIFFERENTIAL, DRIVE SHAFTS, BACKING PLATES, AND TRANSMISSION CROSS MEMBER

SIX POINT - HIGH STRENGTH	5-2722	1625.00
---------------------------	--------	---------

### ENGINE KITS - SEE PAGE 20-22

### REAR COVER KITS - SEE PAGE 31

### STEERING BOX MOUNT & COVER KITS

SIX POINT -HIGH STRENGTH	6-8071	65.50
12 POINT - HIGH STRENGTH	6-8075	75.00

### TRANSMISSION CROSSMEMBER KITS - S10/S15 TRUCKS W/ 4.3L V-6

SIX POINT - HIGH STRENGTH	5-2208	39.50
---------------------------	--------	-------

### TRANSMISSION KITS - SEE PAGE 29-30

**BUTTON**

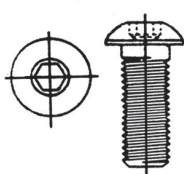

**HEX**

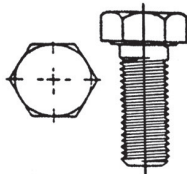

**INDENTED HEX  
(ORIGINAL STYLE)**

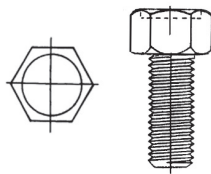

**SOCKET**

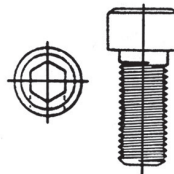

**6-POINT**

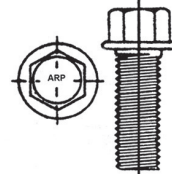

**12-POINT**

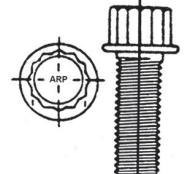

**TOLL FREE ORDER LINE : 1-800-767-4781**



## KITS FOR 1964-1971 LEMANS/GTOS

**BODY KIT-** Every Body Kit includes component kits for Front Body Mount, Bucket Seats ('68-'71), Bumpers, Door Hinges, Door Jambs, Firewall & Cowl, Front & Inner Fenders, Gas Tank, Gravel Pan('68-'71), Grill, Headlights, & Turn Signals, Hood Hinges, Interior, Radiator/Core Support, & Battery Box, Roll Pan('70-'71), Tail Lights, Trunk Hinges, Latch & Catch, and Windshield Trim & Cowl Vent.

Contains one of each component kit

	1964-1965		1966-1967		1968-1969	
BUTTON AND SOCKET HEAD	# 6-2645	\$ 360.50	# 6-2653	\$ 360.75	# 6-2694	\$ 325.00
HEX HEAD	6-2652	370.75	6-2654	370.75	6-2695	345.00
INDENTED HEX HEAD	6-2603	495.00	6-2655	505.00	6-2696	525.00
ORIGINAL STYLE-INDENTED HEX	6-2604	525.00	6-2656	530.00	6-2697	550.00

WITH BLACK STAINLESS WHERE APPROPRIATE

BUTTON AND SOCKET HEAD

HEX HEAD

INDENTED HEX HEAD

ORIGINAL STYLE-INDENTED HEX

WITH BLACK STAINLESS WHERE APPROPRIATE

### 1970-1972 GTO

# 6-2698 \$ 340.75

6-2699 345.00

6-2700 525.00

6-2701 550.00

### 1970-72 LEMANS

# 6-2666 \$385.00

6-2667 390.00

6-2660 435.00

6-2668 470.00

\*\* NOTE INDENTED HEX, & ORIGINAL STYLE BOLTS ARE MADE IN USA \*\*

## ACCESSORY KITS (NOT INCLUDED IN THE BODY KIT)

**CHASSIS KIT** - INCLUDES FRONT & REAR SUSPENSION WITH FRONT SWAY BAR, STEERING BOX, ENGINE MOUNTS & TRANSMISSION CROSSMEMBER KITS - HIGH STRENGTH

\*\*CASTLE NUTS NOT INCLUDED - SEE PAGE 130\*

1964-1969 - SIX POINT	# 6-8161	\$ 799.50
TWELVE POINT	6-8199	815.00
1970-1972 - SIX POINT	6-8162	747.00
TWELVE POINT	6-2749	779.50

- FOR CARS ORIGINALLY EQUIPPED WITH 4 SPEEDS: HAS (4)

LONGER BOLTS FOR THE REAR CONTROL ARMS BRACE

1964-1969 - SIX POINT	6-8163	725.50
TWELVE POINT	6-2748	755.00
1970-1972 - SIX POINT	6-8164	725.00
TWELVE POINT	6-2744	785.50

### ENGINE MOUNTS TO FRAME KITS

SIX POINT -HIGH STRENGTH	6-1945	45.50
TWELVE POINT -HIGH STRENGTH	6-1946	49.50

### FRONT & REAR SUSPENSION KITS

HIGH STRENGTH STAINLESS BOLTS, INCLUDING KNURLED BOLTS & TALL NUTS, COMPLETE WITH ZERKS & COTTERS,

\*\*CASTLE NUTS NOT INCLUDED - SEE PAGE 3\*

1964-69: SIX POINT	6-8156	580.00
TWELVE POINT	6-8198	585.00
1970-72: SIX POINT	6-8157	558.50
TWELVE POINT	6-2745	575.50

- FOR CARS ORIGINALLY EQUIPPED WITH 4 SPEEDS: HAS (4)

LONGER BOLTS FOR THE REAR CONTROL ARMS BRACE

1964-1969: SIX POINT	6-8167	595.00
TWELVE POINT	6-2746	630.00
1970-1972: SIX POINT	6-8168	590.50
TWELVE POINT	6-2747	625.00

### STEERING BOX COVER & MOUNT KITS

SIX POINT - HIGH STRENGTH	6-1936	65.00
TWELVE POINT - HIGH STRENGTH	6-1937	72.00

### TRANSMISSION CROSSMEMBER KITS

SIX POINT - HIGH STRENGTH	6-1768	39.50
TWELVE POINT - HIGH STRENGTH	6-1771	42.00

**BODY MOUNT KITS** - SUPPLEMENT TO FRONT MOUNT:

**1964-67:** (12 BOLTS & WASHERS)

HEX HEAD	# 6-2647	67.50
SOCKET HEAD	6-2648	92.00
SIX POINT - HIGH STRENGTH	6-2661	168.00
TWELVE POINT - HIGH STRENGTH	6-2662	175.00

**1968-72 SEDANS & HARD TOPS:** (8 BOLTS & WASHERS)

HEX HEAD	6-2657	48.00
SOCKET HEAD	6-2658	64.00
SIX POINT - HIGH STRENGTH	6-2675	120.50
TWELVE POINT - HIGH STRENGTH	9-2676	125.00

**1968-72 CONVERTIBLES & WAGONS:** (12 BOLTS & WASHERS)

HEX HEAD	6-2731	70.00
SOCKET HEAD	6-2732	94.00
SIX POINT - HIGH STRENGTH	6-2733	205.00
TWELVE POINT - HIGH STRENGTH	9-2734	210.50

### HIDE AWAY HEADLIGHTS KIT

ORIGINAL STYLE	6-2729	15.50
----------------	--------	-------

### REAR SHOCK MOUNT STUD KIT - CUSTOM

MADE STUDS WITH NUTS & WASHERS	6-8170	86.50
--------------------------------	--------	-------

### REAR SWAY BAR KIT

SIX POINT - HIGH STRENGTH	6-8185	51.50
TWELVE POINT - HIGH STRENGTH	6-8186	53.50

**DOOR STRIKERS KIT** - SOCKET HEAD SHOULDER BOLTS WITH WASHERS

6-8154	59.95
--------	-------

### ENGINE KITS - SEE PAGE 25

### REAR COVER KITS - PAGE 31

### TRANSMISSION KITS - SEE PAGE 29-30

### WHEEL WELL MOULDING KIT

ORIGINAL STYLE - ROUND WASHER HEAD	6-1796	8.00
CUSTOM STYLE - BUTTON HEAD	6-1764	9.00

# KITS FOR MODEL A FORDS

Back in 1969, with my brother at the wheel and my cousin in between, on our first Model A - at least part of one. This one was cut down by a previous owner and had a Model T worm drive truck rear installed to make a poor man's tractor. It made a lousy tractor but it was great for pulling wheelies! We paid 15 bucks for it and still have it.



## BODY KITS FOR MODEL A'S:

DOES NOT INCLUDE TALL HEX HEAD BOLTS

### BED MOUNT KIT

HEX HEAD # 9-2902 \$ 28.00

### BED STRIPS KIT - FOR PICK UPS

CARRIAGE HEAD 9-2900 62.00

### BODY to CHASSIS KITS - FOR ALL MODEL A's

HEX & CARRIAGE HEAD 9-4104 37.00

### DASH KIT

FLAT SOCKET 9-2861 6.50  
SLOTTED OVAL HEAD 9-2862 6.75

### DOOR HINGES KIT : UNDERSIZED (#12) HEADS COUPES & TWO DOORS: (18 PC)

FLAT SOCKET 9-2884 49.00  
SLOTTED FLAT HEAD 9-2885 56.00

### ROADSTERS: (16) WITH DIMPLE WASHERS

FLAT SOCKET 9-2886 42.75  
SLOTTED FLAT HEAD 9-2887 52.00

### DOOR STRIKERS & CATCHES KIT: FOR OPEN CARS (ROADSTERS, (2) KITS NEEDED FOR PHAETONS

FLAT SOCKET 9-2888 7.00  
SLOTTED FLAT HEAD 9-2889 7.25

### ENGINE KITS FOR MODEL A'S - SEE PG 9

### FRONT APRON (SPLASH PAN) KIT

#### 1928-29:

FLAT SOCKET HEAD 9-2863 4.00  
SLOTTED OVALHEAD (STOCK STYLE) 9-2864 4.25

#### 1930-31:

BUTTON HEAD 9-2865 4.00  
SLOTTED ROUND HEAD (STOCK STYLE) 9-2866 4.25

### FRONT BUMPER MOUNT KIT

BUTTON HEAD - WITH LOCK NUTS 9-2855 29.50  
HEX HEAD 9-2856 24.75

### FRONT FENDERS KIT - FOR BRACES & BOLTS TO SPLASH SHIELDS 1928-29 (WITH FORGED BRACKETS):

BUTTON HEAD - WITH LOCK NUTS # 9-2857 \$ 26.00  
HEX HEAD (1/4-20" S HAVE 3/8" WRENCH) 9-2858 30.50

### 1929 - 31 (WITH STAMPED BRACKETS): INCLUDES THE LONGER BOLTS USED ON LATER 1931'S

BUTTON HEAD - WITH LOCK NUTS 9-2870 23.75  
HEX HEAD (1/4-20" S HAVE 3/8" WRENCH) 9-2871 27.50

### GAS TANK & COWL KIT

BUTTON HEAD - WITH LOCK NUTS 9-2868 15.75  
HEX HEAD (3/8 WRENCH) 9-2869 20.50

### HEADLIGHT MOUNT & BULB BRACKET KIT

HEX NUTS & SLOTTED OVAL 9-2860 6.00

### HOOD SHELF KIT

BUTTON HEAD - WITH LOCK NUTS 9-2849 7.50  
SLOTTED ROUND & 'KEP' NUTS 9-2850 7.75

### REAR FENDERS KIT -

#### CARS WITH FORGED BRACKETS:

BUTTON & SPECIAL CARRIAGE HEAD 9-2872 22.75  
HEX & SPECIAL CARRIAGE HEAD 9-2873 23.00

#### CARS WITH STAMPED BRACKETS:

BUTTON & SPECIAL CARRIAGE HEAD 9-2874 21.75  
HEX & SPECIAL CARRIAGE HEAD 9-2875 22.50

### RUNNING BOARDS KIT - BOLTS BOARDS TO FENDERS, INCLUDES NUTS & LOCKS FOR BRACKETS:

FLAT TOP CARRIAGE HEAD 9-2867 13.75

### WINDSHIELD KIT - FOR 1929-30 OPEN CARS

FLAT SOCKET 9-2897 6.00  
SLOTTED OVAL HEAD 9-2898 6.50

# KITS FOR 1932 FORD ROADSTERS

**BODY KIT-** Every Body Kit includes component kits for Body Mounting, Cowl Vent, Door Hinges & Latches, floor board, Gas Tank, Grill & Grill Shell, Hood Hold down & Latch, Interior, Radiator Rod hardware, Trunk Hinges, Latch & Catch, Windshield & Top.

BUTTON HEAD & FLAT SOCKET HEAD  
# 9-4200 \$ 265.00

HEX HEAD & SLOTTED HEAD  
(STOCK STYLE) 9-4201 265.00

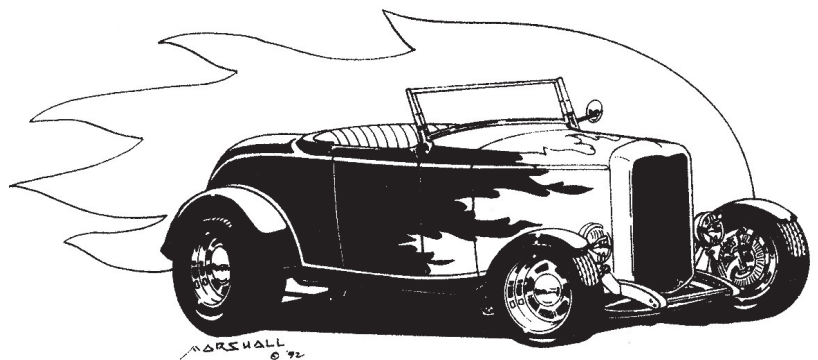

## ACCESSORY KITS (NOT INCLUDED IN THE BODY KIT)

### AFTER MARKET CHASSIS KITS - PAGES 32-33

**SLOTTED 'SEX' SCREWS** - FOR COUPE SUN VISORS  
SLOTTED OVAL HEAD (PAIR) # 9-4205 \$ 30.75

### (6) BOLTS FOR 32 FORD SEDAN SEAT PIVOTS

BUTTON HEAD 6-9402 81.00  
HEX HEAD 6-9403 82.00

**SLOTTED WINDOW STOP SCREW** - FOR 28-40 FORD  
WINDOW STOPS (PAIR) 9-4000 23.00



# 58 KITS FOR 1939 DELUXE THROUGH 1948 FORD



*This copper toned beauty belongs to one of the Road Tour members at our open house in June of 2010.*

**BODY KIT-** Each Body Kit includes component kits for Bumpers, Cowl Vent (39-40), Door Hinges, Door Jambs, Front & Inner Fenders, Filler Panel & Grill, Glove Box, Headlights, Hood Hinges, Latch & Catch, Hood Trim, Rear Fenders, Running Boards (39-40), Tail Lights, Trunk Hinges, Latch & Catch, Visors, and Window Trim.

	<b>1939 DELUXE &amp; 1940</b>		<b>1941-42*</b>		<b>1946-48</b>	
BUTTON HEAD (pictured above)	# 9-4900	\$ 270.00	9-5005	\$385.75	9-5007	\$ 280.00
HEX HEAD	9-4901	325.00	9-5006	410.00	9-5008	275.00

\* HAS RECTANGULAR HEAD BUMPER BOLTS

## ACCESSORY KITS (NOT INCLUDED IN THE BODY KIT)

### BODY MOUNTING KITS: NOTE A STOCK STYLE

HEX KIT IS NOT OFFERED BECAUSE THE BODY MOUNT BOLTS ARE ONLY 5/16 DIAMETER (37-40), 41-48 HAVE (2) THAT ARE 3/8" DIAMETER, THE REST ARE ONLY 5/16).

<b>1937-40:</b> (BOLTS, NUTS & WASHERS) -		
6 POINT - HIGH STRENGTH & CARRIAGE HEAD	# 9-4940	\$ 97.50
12 POINT - HIGH STRENGTH & CARRIAGE HEAD	9-4941	99.50
<b>1941-48:</b> (BOLTS, NUTS & WASHERS)		
SIX POINT - HIGH STRENGTH	9-5002	155.00
TWELVE POINT - HIGH STRENGTH	9-5003	162.50

**1939-40 BUMPER BOLTS** - SET OF (4) OVAL HEAD CARRIAGE BOLTS NEEDED WHEN THE BUMPERETS AREN'T USED. POLISHED OVAL CARRIAGE HEADS & NUTS 5-9999 88.00

**CHASSIS KIT-** For 1937-40 chassis using TCI front & rear suspension. Includes component kits for upper & lower control arms, steering rack (except castle nuts - measure height and order as needed), steering box, front & rear sway bars, engine mounts, proportioning valve, leaf springs (including U bolts & tall nuts), grease fittings & cotter pins. Check out the other chassis kits on pages 32-33. SIX POINT - HIGH STRENGTH 9-4999 899.50

**ENGINE KITS** - SEE PAGE 10

### HOOD HINGE SHOULDER BOLTS -

- 17-4 PH HIGH STRENGTH STAINLESS, MADE IN OUR SHOP -

<b>1939-48:</b> WITH STOCK 1/4-28 THREADS		
BUTTON HEAD	# 9-4950	\$ 103.50
HEX HEAD	9-4951	107.00

<b>1939-48:</b> WITH OVERSIZED 5/16-24 THREADS:		
BUTTON HEAD	6-9743	103.50
HEX HEAD	6-9744	107.00

### 1939-40 TRUNK HINGE SHOULDER BOLTS

BUTTON HEAD	6-9741	44.75
HEX HEAD	6-9742	45.25

### DOWEL (GUIDE) PINS - FOR 1941-48

# 2-8099 \$ 19.50 EACH



### CONVERTIBLE TOP KITS (CUSTOM MADE)

#### PIVOT BOLTS FOR 1933/34 CONVERTIBLE TOP: (6)

BUTTON HEAD - CUSTOM	# 6-9733	\$141.50
HEX HEAD - ORIGINAL	6-9734	135.25

#### PIVOT BOLTS FOR 1935/36 CONVERTIBLE TOP: (6)

BUTTON HEAD - CUSTOM	6-9735	142.50
HEX HEAD - ORIGINAL	6-9736	135.25

#### RIVET REPLACEMENT KITS FOR 1935/36 FORD TOP:

BUTTON HEAD - CUSTOM STYLE	6-9404	391.75
----------------------------	--------	--------

#### 1939-40: (102 PC. BOLTS, NUTS & WASHERS)

BUTTON HEAD - CUSTOM	6-9739	428.75
HEX HEAD - STOCK	6-9740	451.75



#### 1941- EARLY 1942 (3 WINDOW TOP) SHOWN ABOVE

BUTTON HEAD & LOCK NUTS - CUSTOM - 52 PCS	6-9700	481.25
HEX HEAD, NUTS & SPLITS - ORIGINAL - 70 PCS	6-9701	495.25

#### LATE 1942 - 1948 (5 WINDOW TOP)

BUTTON HEAD & LOCK NUTS - CUSTOM - 92 PCS	6-9706	472.75
HEX HEAD, NUTS & SPLITS - ORIGINAL - 112 PCS	6-9707	506.75

**ECCENTRIC SHOULDER BOLTS FOR LATE 1942 THRU 1948 FORDS**  
AVAILABLE IN THE STOCK HEX HEAD OR CUSTOM BUTTON HEAD

BUTTON HEAD	2-8064	\$28.00 EACH
HEX HEAD	2-8065	\$29.00 EACH

(8) ARE INCLUDED IN CONVERTIBLE KITS

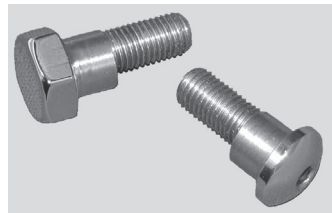



# KITS FOR 1949 - 1951 FORD

**BODY KIT-** Each Body Kit includes component kits for Battery Box, Bumpers, Door Hinges, Door Jambs, Front & Inner Fenders, Firewall, Filler Panel & Grill, Gas Tank Mount Headlights & Turn Signals, Hood Hinges, Horn, Latch & Catch, Hood Trim, Interior, Radiator, Trunk Hinges, Latch & Catch, and Window Trim.

	<b>1949-51 SEDAN</b>	<b>1949-51 HARD TOP</b>
BUTTON & FLAT SOCKET HEAD	# 9-5100 \$ 325.00	# 9-5168 \$ 350.00
HEX & INDENTED HEAD - ORIGINAL STYLE	9-5102 560.00	9-5169 595.50

## ACCESSORY KITS (NOT INCLUDED IN THE BODY KIT)

### BODY MOUNTING KITS:

<b>1949-51:</b> (BOLTS, NUTS & WASHERS) -	
6 POINT - HIGH STRENGTH	# 9-5162 \$ 110.00
12 POINT - HIGH STRENGTH	9-5163 115.50

### ENGINE KITS - SEE PAGE 10

### HOOD HINGE SHOULDER BOLTS - 17-4PH

1949-53: HIGH STRENGTH FOR LONG WEAR	
BUTTON HEAD	8-6001 97.50
HEX HEAD (STOCK STYLE)	8-6002 100.25

### CONVERTIBLE TOP KITS

<b>1949:</b> (102 PC. BOLTS, NUTS & WASHERS)	
BUTTON HEAD - CUSTOM	# 6-9710 \$ 610.25
HEX HEAD - STOCK	6-9711 638.75
<b>1950:</b> (104 PC. BOLTS, NUTS & WASHERS)	
BUTTON HEAD - CUSTOM	6-9712 610.50
HEX HEAD - STOCK	6-9713 639.00

**A BUTTON HEAD KIT FOR A 1950 IS SHOWN BELOW:**

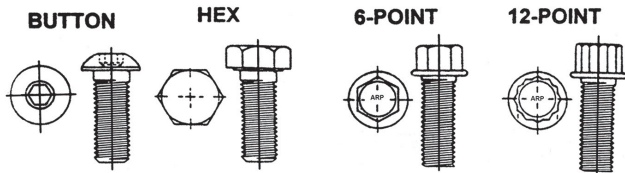

# KITS FOR 1955 - 1956 FORD

**BODY KIT-** Each Body Kit includes component kits for Battery Box, Bumpers, Door Hinges, Door Jambs, Front & Inner Fenders, Firewall, Filler Panel & Grill, Gas Tank Mount Headlights & Turn Signals, Hood Hinges, Horn, Latch & Catch, Hood Trim, Interior, Radiator, Lift Gate / Tail Gate (Station Wagon), Trunk Hinges / Latch & Catch (Sedan) , and Window Trim.

	<b>SEDAN</b>	<b>STATION WAGON</b>
BUTTON & FLAT SOCKET HEAD	# 9-5500 \$ 255.00	# 9-5502 \$ 310.00
HEX & INDENTED HEAD	9-5501 375.00	9-5503 415.00

## ACCESSORY KITS (NOT INCLUDED IN THE BODY KIT)

### ENGINE KITS - SEE PAGE 11

### FRONT SUSPENSION KIT (1954-59)

SIX POINT -HIGH STRENGTH	# 9-5250 \$ 490.50
12 POINT - HIGH STRENGTH	9-5251 505.00

### STEERING BOX MOUNT KIT

SIX POINT -HIGH STRENGTH	# 9-5252 \$ 40.50
12 POINT - HIGH STRENGTH	9-5253 45.50

**POSIES CUSTOM RANCH WAGON - Now equipped with a super-charged 'Coyote' quad cam modular V8 by Roush - the body and engine are put together with our button head bolts!**



*Photo Scott Killeen*



**TOLL FREE ORDER LINE : 1-800-767-4781**

# KITS FOR 1966-1969 FORD FAIRLANES

Each Body Kit includes component kits for Brake & Fuel Lines, Bumpers, Door Hinges, Door Jambs, Firewall & Cowl, Front & Inner Fenders, Gas Tank, Filler Panel, Grill, Headlights, & Turn Signals, Hood Hinges Latch & Catch, Interior, Radiator/Core Support, & Battery Box, Tail Lights, Trunk Hinges, Latch & Catch (except Ranchero), and Gas Tank Filler. Body kits for Ranchero also include kits for Bed Floor Plate, Tail Gate and Top of Bed trim.



**Todd's 1968 Fairlane fastback at the drags.**

**\*\* NOTE ORIGINAL STYLE BOLTS ARE MADE IN USA \*\***

Contains one of each component kit:

- BUTTON HEAD
- INDENTED HEX HEAD
- ORIGINAL STYLE-INDENTED HEX
- WITH BLACK STAINLESS WHERE APPROPRIATE

<b>1966-1967 545 PIECES!</b>		<b>1967 RANCHERO</b>		<b>1968-1969 645 PIECES!</b>	
# 6-9200	\$ 315.00	# 6-9250	\$ 370.25	# 6-9300	\$ 350.75
6-9201	455.00	6-9251	525.00	6-9301	550.00
6-9202	480.00	6-9252	550.00	6-9302	575.00

## - ACCESSORY KITS (NOT INCLUDED IN THE BODY KIT) -

**ENGINE KITS** - SEE PAGES 12-14

**TRANSMISSION KITS** - SEE PAGES 29-31

### **STEERING BOX KITS**

SIX POINT - HIGH STRENGTH	# 6-4075	\$ 65.00
TWELVE POINT - HIGH STRENGTH	6-4076	70.00

# KITS FOR 1955-1963 FORD THUNDERBIRDS

**BODY KIT-** Includes component kits for Front Body Mount, Front & Rear Bumpers, Door Hinges, Door Jambs, Firewall & Cowl, Front Fender Braces, Filler Panel, Fresh Air Vent, Grill & Splash Pan, Hard Top Hardware, Headlights, Hood Hinges, Inner Fender Splash Pans, Interior, Radiator/Core Support, Seats Mounts, Trunk Hinges, Latch & Catch, and Vent Cable Brackets.

**\*\* NOTE ORIGINAL STYLE BOLTS ARE MADE IN USA \*\***

Contains one of each component kit - over 700 pieces!

<b>1955-1956</b> ORIGINAL STYLE-INDENTED HEX WITH BLACK STAINLESS WHERE APPROPRIATE	# 6-8562	\$ 580.00
<b>1957</b> ORIGINAL STYLE-INDENTED HEX WITH BLACK STAINLESS WHERE APPROPRIATE	6-8572	599.00
<b>1958-1960</b> ORIGINAL STYLE - INDENTED HEX WITH BLACK STAINLESS WHERE APPROPRIATE	6-8602	650.00
<b>1961-1963</b> ORIGINAL STYLE - INDENTED HEX WITH BLACK STAINLESS WHERE APPROPRIATE	6-8702	699.00

## - ACCESSORY KITS (NOT INCLUDED IN THE BODY KIT) -

**ENGINE KITS** - SEE PAGES 11 & 14

### **SOFT TOP KIT FOR 1955-57 - 186 PIECES**

HEX & PHILLIPS HEAD # 6-8552 \$ 41.75

### **BODY MOUNT KIT FOR 1955-57 WITH**

### **"DOG POINT" HEX HEAD BOLTS & STUDS**

1955-1957 # 6-8550 \$ 118.75



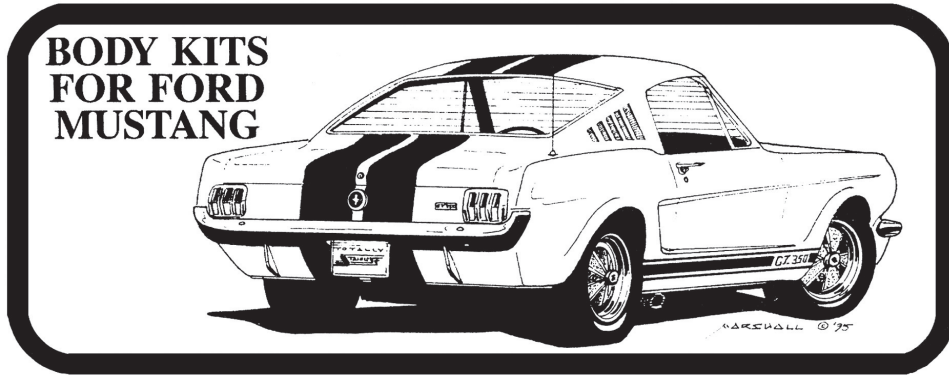

## KITS FOR 1964 1/2 - 1970 FORD MUSTANGS

**BODY KIT-** Every Body Kit includes component kits for Back Up Lights, Battery Box, Bottom of Dash, Bucket Seats, Bumpers, Firewall, Door Hinges, Door Jambs, Emergency Brake Handle & Dash Brace, Front Turn Signals, Front Fender Braces & Front Shocks, Front & Inner Fenders, Grill, Headlight Bucket, Bezel, Gravel Pan & More, Hood Hinges, License Plate, Hood Latch & Catch, Basic Interior, Radiator Support & Horn, Rear Corners, Rear Roll Pan & Bumperettes, Regulator, Starter Relay & Windshield Washer Bag, Tail Lights, and Trunk Hinges, Latch & Catch. Available in 4 different head styles and over 500 pieces in each kit!

Contains one of each component kit

	1964 1/2-1965		1966	
BUTTON & FLAT SOCKET HEAD	# 6-4087	\$ 370.75	# 6-4000	\$ 385.00
HEX & PHILLIPS HEAD	6-4088	390.75	6-4001	390.00
INDENTED HEX HEAD	6-4089	500.00	6-4002	485.00
ORIGINAL STYLE-INDENTED HEX	6-4090	575.00	6-4003	520.00

WITH BLACK STAINLESS WHERE APPROPRIATE

	1967-1968		1969-1970	
BUTTON & FLAT SOCKET HEAD	6-4100	370.75	6-4200	315.00
HEX HEAD	6-4101	390.75	6-4201	330.00
INDENTED HEX HEAD	6-4102	450.00	6-4202	400.00
ORIGINAL STYLE-INDENTED HEX	6-4103	525.00	6-4203	450.00

WITH BLACK STAINLESS WHERE APPROPRIATE

\*\* NOTE INDENTED HEX, & ORIGINAL STYLE BOLTS ARE MADE IN USA \*\*

### ACCESSORY KITS (NOT INCLUDED IN THE BODY KIT)

#### ENGINE KITS - SEE PAGES 10-12

#### FOLD DOWN REAR SEAT KITS

-1965-1970 FASTBACKS

BUTTON & PHILLIPS HEAD	# 6-4059	\$ 10.00
HEX & PHILLIPS HEAD	6-4060	10.50
INDENTED HEX & PHILLIPS HEAD	6-4061	15.00

#### FLIP DOWN GAS CAP KIT

PHILLIPS HEAD	6-4142	5.00
---------------	--------	------

#### ENGINE MOUNTS TO FRAME KITS

-1964 1/2-1970

SIX POINT - HIGH STRENGTH	6-4073	75.00
TWELVE POINT - HIGH STRENGTH	6-4074	80.00

#### FRONT SUSPENSION KIT: HIGH STRENGTH STAINLESS PLUS GREASE FITTINGS AND COTTER PINS

\*\*CASTLE NUTS NOT INCLUDED - SEE PAGE 130\*

SIX POINT - HIGH STRENGTH	6-4091	275.50
---------------------------	--------	--------

#### GAS TANK MOUNT KIT

INDENTED HEX WASHER HEAD	6-4099	10.00
--------------------------	--------	-------

#### HOOD HINGE RIVET REPLACEMENT KIT

SHOULDERED RIVETS & LOCK NUTS	6-4014	399.00
-------------------------------	--------	--------

#### OUTER REAR WINDOW TRIM KITS

-1967-1968 (ONLY FOR COUPES)

PHILLIPS HEAD	6-4138	4.25
POLISHED PHILLIPS HEAD	6-4139	8.50

#### REAR PANEL KITS - FOR FASTBACKS

-1964 1/2-1966

PHILLIPS HEAD	6-4058	10.25
---------------	--------	-------

-1967-1968

PHILLIPS HEAD	6-4140	12.00
POLISHED PHILLIPS HEAD	6-4141	35.00

-1969-1970

PHILLIPS HEAD	6-4241	11.50
---------------	--------	-------

#### STEERING BOX COVER & MOUNT KITS

-1964 1/2-1970

SIX POINT - HIGH STRENGTH	6-4075	65.00
TWELVE POINT - HIGH STRENGTH	6-4076	70.00

#### TRANSMISSION KITS - SEE PAGE 29-30

#### VISORS, REAR VIEW MIRROR AND WINDSHIELD TRIM KITS

-1964 1/2-1966

#### CONVERTIBLE

POLISHED PHILLIPS	6-4056	22.00
-------------------	--------	-------

#### COUPE & FASTBACK

PHILLIPS HEAD	6-4057	8.75
---------------	--------	------

#### -1967-1968: COUPE & FASTBACK

POLISHED PHILLIPS	6-4137	14.00
-------------------	--------	-------

#### REAR SUSPENSION KITS

-CARS WITH 2 5/16" AXLE TUBES:

SIX POINT - HIGH STRENGTH	6-4093	275.00
---------------------------	--------	--------

-CARS WITH 2 3/4" AXLE TUBES:

SIX POINT - HIGH STRENGTH	6-4094	285.00
---------------------------	--------	--------

-CARS WITH 3" AXLE TUBES

SIX POINT - HIGH STRENGTH	6-4096	299.00
---------------------------	--------	--------



# BODY KITS FOR FORD MUSTANG 1978-93

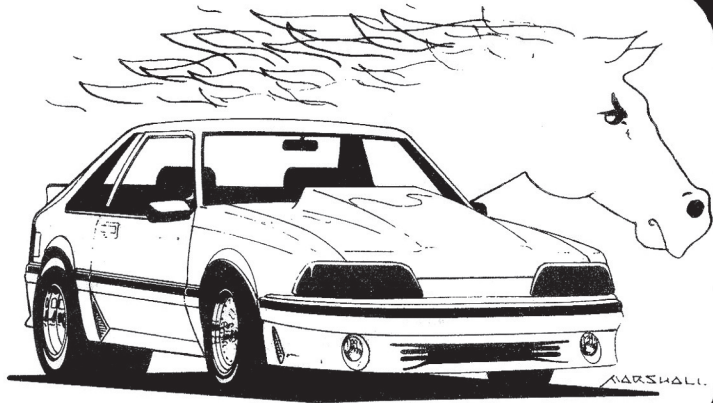

## KITS FOR 1978-1993 FORD MUSTANGS

### BATTERY BOX KITS

<b>-1973-1983 (U.S. THREAD)</b>		
BUTTON HEAD	# 6-0416	\$ 5.00
HEX HEAD	6-0417	5.50
<b>-1984-1993</b>		
BUTTON HEAD	5-1011	5.25
HEX HEAD	5-1012	5.50

### DOOR HINGES

HEX HEAD	6-0429	10.00
INDENTED HEX HEAD	6-0430	25.00
SOCKET HEAD	6-0431	11.00

### FRONT/INNER FENDERS KITS

<b>-1978-1984 (U.S. THREAD) - 44 PIECES</b>		
BUTTON HEAD	6-0426	13.50
HEX HEAD	6-0427	15.00
INDENTED HEX HEAD	6-0428	25.00
<b>-1985-1993 (METRIC THREAD) - 52 PIECES</b>		
BUTTON HEAD	5-1017	15.25
HEX HEAD	5-1018	15.50

### HOOD HINGE KITS - DOES BOTH

<b>-1978-1981 (1/4" U.S. THREAD)</b>		
BUTTON HEAD	6-0402	7.75
HEX HEAD	6-0401	8.75
INDENTED HEX HEAD	6-0432	11.00
<b>-1982 (5/16" U.S. THREAD)</b>		
BUTTON HEAD	6-0405	6.50
HEX HEAD	6-0406	6.75
<b>-1983-1993 (METRIC THREAD)</b>		
BUTTON HEAD	5-1002	10.50
HEX HEAD	5-1003	10.75

### HOOD LATCH & CATCH AND RADIATOR SUPPORT KITS - 44 PIECES

<b>-1978-1983 (U.S. THREAD)</b>		
BUTTON HEAD	# 6-0413	\$ 16.50
HEX HEAD	6-0414	18.75
INDENTED HEX HEAD	6-0433	40.00
<b>-1984-1993 (METRIC THREAD)</b>		
BUTTON HEAD	5-1008	17.25
HEX HEAD	5-1009	17.50

### HOOD PROP ROD BRACKET KITS

<b>-1978-1982 (SELF TAPPING)</b>		
HEX HEAD	6-0408	4.00
PHILLIPS HEAD	6-0409	4.25
<b>-1983 (1/4" U.S. THREAD)</b>		
BUTTON HEAD	6-0410	4.00
HEX HEAD	6-0411	4.25
<b>-1984-1993 (METRIC THREAD)</b>		
BUTTON HEAD	5-1005	4.00
HEX HEAD	5-1006	3.25

### TRUNK LID/LATCH/LICENSE PLATE KIT

<b>-1978-1983 (U.S. THREAD)</b>		
BUTTON HEAD	6-0421	8.00
HEX HEAD	6-0422	9.00
<b>-1984-1993 (METRIC THREAD)</b>		
BUTTON HEAD	5-1014	7.75
HEX HEAD	5-1015	8.00
<b>-1978-1993 HATCHBACK (U.S. THREAD)</b>		
BUTTON HEAD	6-0424	10.75
HEX HEAD	6-0425	9.00

### WINDSHIELD WIPER MOTOR KITS

HEX HEAD	6-0419	4.25
PHILLIPS HEAD	6-0420	4.00

\*\* NOTE INDENTED HEX BOLTS ARE MADE IN USA \*\*

## ACCESSORY KITS

**ENGINE KITS** - SEE PAGE 10

**TRANSMISSION KITS** - SEE PAGE 29-30

**DOOR STRIKERS** - 1983-1993

PAIR WITH WASHERS	# 6-0449	\$ 95.50
-------------------	----------	----------

**ACCESSORY BRACKETS KIT FOR 1987-1993  
MUSTANGS WITH A 5.0L (302) V8**

INDENTED HEX & HEX HEAD	# 6-0450	\$ 70.00
SOCKET HEAD	6-0451	82.00
SIX POINT - HIGH STRENGTH	6-0452	162.50
TWELVE POINT - HIGH STRENGTH	6-0453	165.00



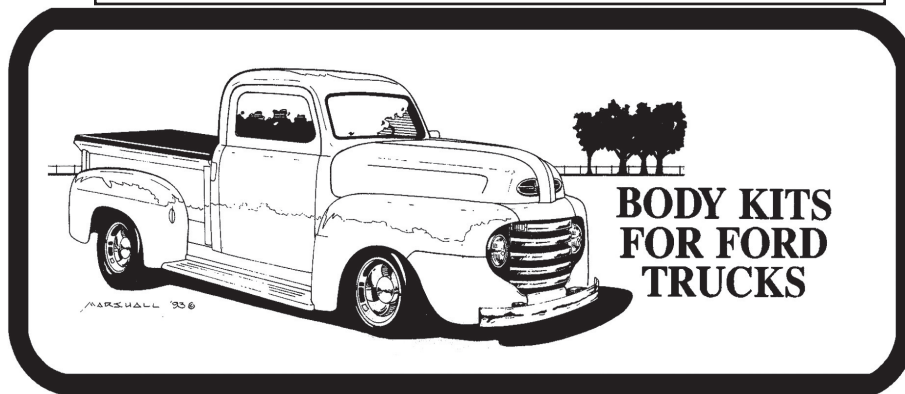

**KITS FOR 1940-1947 FORD TRUCKS**

**BODY KIT-** Every Body Kit includes component kits for Door Jambs, Door Hinges, Door Handles, Front Bumper, Front Body Mount (42-47), Grill & Splash Pan, Headlights, Turn Signals, Front Fenders, Radiator, Hood Latch & Catch, Firewall and Interior Kits. Body Kits with a bed also include kits for: Posts, & Tailgate, Rear Fenders, Running Boards, Bed Strips, and Spare Tire Mount Kits.

-IF YOU HAVE A FLATBED OR A PANEL TRUCK ORDER A BEDLESS BODY KIT-

**BEDLESS BODY KITS**

1940-1941:

BUTTON/SOCKET HEAD	# 9-4700	\$ 225.00
HEX/SLOTTED HEAD	9-4701	240.50

1942-1947:

BUTTON/SOCKET HEAD	6-6800	240.75
HEX/SLOTTED HEAD	6-6802	235.50

**1940-47 BED KITS**

BUTTON HEAD	6-6827	125.00
HEX HEAD	6-6828	120.50

**BODY KITS WITH A STEPSIDE BED**

1940-1941:

BUTTON/SOCKET HEAD	# 9-4702	\$ 325.00
HEX/SLOTTED HEAD	9-4703	320.00

1942-1947:

BUTTON/SOCKET HEAD	6-6803	345.75
HEX/SLOTTED HEAD	6-6804	325.00

**1942-47 CAB MOUNT KIT**

WITH SPRINGS	6-6836	155.00
SPRINGS FOR FRONT MOUNT (2)	6-0311	25.00

**KITS FOR 1948-1952 FORD TRUCKS**

**BODY KIT-** Every Body Kit includes component kits for Front Bumper, Cab Mount, Cowl Vent, Door Hinges, Latch & Catch, Door Panel (Interior), Front/Inner Fenders, (48-50) Grill Top & Support, Horn Bracket, Hood, Interior, Radiator Support & Braces, Seat Mounts, Steering Column Clamp Bolt, and Transmission Cover.

Body Kits with Beds also include kits for; Bed Strip & Side Angles, Running Boards & Brackets, Rear Bumper, Rear Fender, Tailgate, and Tail Lights & License Plate kits.

-IF YOU HAVE A FLATBED OR A PANEL TRUCK ORDER A BEDLESS BODY KIT-

**BEDLESS BODY KITS - 782 PIECES!**

-1948-1950:

BUTTON/SOCKET HEAD	# 6-0362	\$ 270.50
HEX/PHILLIPS HEAD	6-0363	265.50

-1951-1952:

BUTTON/SOCKET HEAD	6-0364	260.00
HEX/PHILLIPS HEAD	6-0365	255.00

**BODY KITS WITH A BED - 1172 PIECES!**

-1948-1950:

BUTTON/SOCKET HEAD	# 6-0301	\$ 415.00
HEX/PHILLIPS HEAD	6-0302	415.50

-1951-1952:

BUTTON/SOCKET HEAD	6-0359	410.00
HEX/PHILLIPS HEAD	6-0357	400.00

**ACCESSORY KITS (NOT INCLUDED IN THE BODY KIT)**

**CLUTCH COVER (DUST COVER) KITS**

HEX HEAD	# 6-0360	\$ 13.00
INDENTED HEX HEAD	6-0355	20.00

**BED MOUNT KIT - HEX/FLAT SOCKET**

UNPOLISHED	6-0305	55.00
POLISHED	6-0316	70.00

**3 SPEED TRANSMISSION KIT**

TAILSHAFT HOUSING, SIDE COVER, SHIFT AND SPEEDOMETER CABLE

HEX HEAD	# 6-0354	\$ 20.00
----------	----------	----------

<b>SPRINGS FOR RADIATOR MOUNT (2)</b>	6-0311	25.00
(1942-52)		



**REAR FENDER BOLTS FOR 1948-79 STEPSIDE FORD TRUCKS!**

- MADE FOR AFTERMARKET BEDSIDES WITH SQUARE HOLES. SPECIAL FLAT HEAD WITH SHORT HEIGHT SQUARE.

5/16-24 x 11/16 (WITH SQUARE) # 2-0773 \$ 2.99

PACK OF 24 BOLTS 6-0312 \$65.00

24 BOLTS/NUTS/FLAT & LOCK WASHERS 6-0314 \$85.00

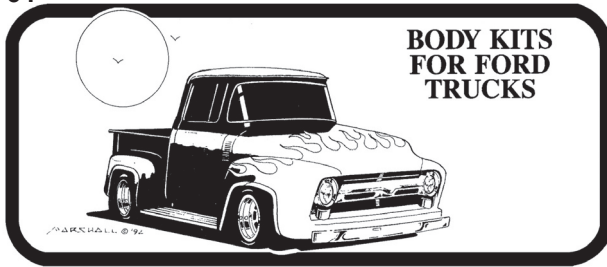

## KITS FOR 1953-1956 FORD TRUCKS

**BODY KIT-** Every Body Kit includes component kits for Battery Box, Front Bumper, Cowl Vent, Door Hinges, Door Jambs, Firewall, Fresh Air Vent, Front Fender Brace Rod, Front/Inner Fenders, Hood Brace, Hood Hinges, Hood Latch, Interior, Radiator Support, Seat Mounts, and Splash Guards/Gravel Pan. Stepside Body Kits include the Bedless kit plus: Bed Strip & Side Angles, Front Bed Panel, Running Boards & Brackets, Rear Bumper, Rear Fender (nuts & washers only), Tailgate, and Tail Lights & License Plate kits.  
-IF YOU HAVE A FLATBED TRUCK ORDER A BEDLESS BODY KIT-

Contains one of each component kit

\*\* NOTE ORIGINAL STYLE INDENTED HEX BOLTS ARE MADE IN USA \*\*

### **BEDLESS BODY KITS - 780 PIECES!**

BUTTON/SOCKET HEAD	# 6-0271	\$ 260.75
HEX HEAD	6-0272	250.00
INDENTED HEX HEAD	6-0293	310.00
SIX POINT - POLISHED	6-0270	715.00

### **STEPSIDE BODY KITS - 1198 PIECES!**

BUTTON/FLAT SOCKET HEAD	# 6-0246	\$ 415.00
HEX HEAD	6-0255	375.00
INDENTED HEX HEAD	6-0294	499.00
SIX POINT - POLISHED	6-0298	999.00

### **PANEL TRUCK BODY KITS - 998 PIECES!**

BUTTON/FLAT SOCKET HEAD	# 6-0200	\$ 285.00
HEX HEAD	6-0221	330.00
INDENTED HEX HEAD	6-0230	340.00

## **ACCESSORY KITS (NOT INCLUDED IN THE BODY KIT)**

### **BED MOUNT BOLT KIT**

BUTTON/FLAT SOCKET	# 6-0309	41.75
SLTD FLAT/SLTD ROUND	6-0310	31.00

### **CAB MOUNT BOLT KIT**

HEX HEAD	6-0275	41.00
SOCKET HEAD	6-0276	38.00
SIX POINT - HIGH STRENGTH	6-0274	120.00

### **MASTER CYLINDER MOUNT KIT**

HEX HEAD	6-0356	6.50
----------	--------	------

### **ENGINE KITS - SEE PAGES 10-11**

### **3 SPEED TRANSMISSION KIT -SIDE COVER, SHIFT LEVERS, SPEEDO, CABLE & TAILSHAFT HOUSING**

HEX HEAD	# 6-0354	\$ 18.50
----------	----------	----------

### **CLUTCH COVER (DUST COVER) KIT**

HEX HEAD	6-0360	13.00
INDENTED HEX HEAD	6-0355	25.00
SIX POINT - HIGH STRENGTH	6-0374	70.00

### **FRONT BODY MOUNT KIT**

SIX POINT - HIGH STRENGTH	6-0273	22.50
---------------------------	--------	-------

### **HOOD HINGE SHOULDER BOLTS - SET OF (4)**

DRILLED - 17-4 PH	BUTTON HEAD	6-0201	115.00
HIGH STRENGTH	HEX HEAD	6-0202	120.00

## KITS FOR 1957-1960 FORD TRUCKS

**BODY KIT -** Every Body kit includes component kits for Front Bumper, Cowl Vent, Door Hinge, Jambs, Latch & Catch, Firewall, Front Fender, Headlight Bezel & Front Turn Signals, Hood Hinge, Latch & Catch, Interior Trim Screw, Inner Fender, Radiator Support & Horn, Seat Mounting, and Transmission Cover. Body Kits with Beds also include all appropriate bed component kits listed on the next page under bed kits.

-IF YOU HAVE A FLATBED OR A PANEL TRUCK ORDER A BEDLESS BODY KIT-

Contains one of each component kit

### **BEDLESS BODY KITS**

BUTTON/SOCKET HEAD	# 6-0003	\$ 255.00
HEX HEAD	6-0007	240.75
INDENTED HEX HEAD	6-6264	310.00

### **BODY KITS WITH A STYLESIDE BED**

BUTTON/SOCKET HEAD	6-0049	315.00
HEX HEAD	6-0050	300.75
INDENTED HEX HEAD	6-6266	390.00

### **BODY KITS WITH A STEPSIDE BED**

BUTTON/SOCKET HEAD	# 6-0045	\$ 395.00
HEX HEAD	6-0046	385.00
INDENTED HEX HEAD	6-6265	465.00

\*\* NOTE ORIGINAL STYLE INDENTED HEX BOLTS ARE MADE IN USA \*\*

## **ACCESSORY KITS (NOT INCLUDED IN THE BODY KIT)**

### **CAB MOUNT BOLT KIT**

HEX HEAD	6-0051	56.25
----------	--------	-------

### **FRONT BODY MOUNT KIT**

HEX HEAD	6-6025	12.00
----------	--------	-------

### **STEERING BOX MOUNT & COVER KIT**

SIX POINT - HIGH STRENGTH	6-0023	60.00
---------------------------	--------	-------

### **ENGINE KITS - SEE PAGES 11-14**

**BED KITS FOR 1957-1960 TRUCKS:** - Bed Kits include component kits for Bed Mounts, Tailgate, and Tail Lights. Stepside Bed kits also include: Bed Strip & Side Angles, Rear Bumper & License Plate, Front Bed Panel, Rear Fenders, and Side Steps.

Contains one of each component kit

### STYLESIDE BED KITS

BUTTON/HEX HEAD	# 6-0052	\$ 85.00
HEX HEAD	6-0053	85.50

### STEPSIDE BED KITS

BUTTON/NYLON LOCKING NUTS	#6-0268	\$165.00
HEX/HEX NUTS	6-0269	175.50

## BODY KITS FOR FORD TRUCKS

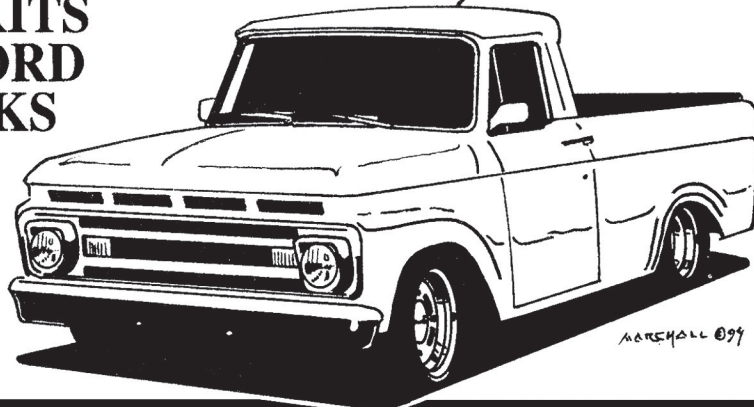

## BODY KITS FOR 1961-1966 FORD TRUCKS

**BODY KIT-** Every Body Kit includes component kits for Bumper(front bumper & brackets with polished carriage), Door Hinges, Door Jambs, Latch & Catch(does both), Firewall, Front Fender (does both), Headlight Bezel & Front Turn Signals, Hood Hinges(does both), Hood Latch & Catch, Interior Door Panel, Interior Trim Screws, Inner Fender, Radiator Support, Front Panel & Horn, Seat Mounting, Starter & Horn Relays, Regulator & Wiring Harness, and Splash Guards(for panels that mount to bottom front corners of frame).

Body Kits with Beds also include all appropriate bed component kits listed on the next page under bed kits.

-IF YOU HAVE A FLATBED OR A PANEL TRUCK ORDER A BEDLESS BODY KIT-

### BEDLESS BODY KITS

#### 1961-1964:

BUTTON HEAD	# 6-6016	\$ 250.50
HEX HEAD	6-6017	255.75
INDENTED HEX HEAD	6-6270	399.00

#### 1965-1966:

BUTTON HEAD	6-6289	215.50
HEX HEAD	6-6290	235.00
INDENTED HEX HEAD	6-6291	325.00

### BODY KITS WITH A STEPSIDE BED

#### 1961-1964:

BUTTON HEAD	6-6061	380.00
HEX HEAD	6-6062	385.50
INDENTED HEX HEAD	6-6271	550.00

#### 1965-1966:

BUTTON HEAD	6-6091	350.50
HEX HEAD	6-6292	365.00
INDENTED HEX HEAD	6-6293	480.00

### BODY KITS WITH A STYLESIDE BED

#### 1961-1964:

BUTTON HEAD	# 6-6064	\$ 345.75
HEX HEAD	6-6065	350.25
INDENTED HEX HEAD	6-6272	499.00

#### 1965-1966:

BUTTON HEAD	6-6294	315.00
HEX HEAD	6-6295	325.00
INDENTED HEX HEAD	6-6296	430.00

### BODY KITS - 61-64 WITH A 1957-60 STYLESIDE BED

BUTTON HEAD	6-6070	335.00
HEX HEAD	6-6071	310.50
INDENTED HEX HEAD	6-6273	475.00

### BODY KITS WITH A UNIBODY BED - 1961-63

BUTTON HEAD	6-6067	370.00
HEX HEAD	6-6068	360.50
INDENTED HEX HEAD	6-6274	550.00

\*\* NOTE ORIGINAL STYLE INDENTED HEX BOLTS ARE MADE IN USA \*\*

## ACCESSORY KITS (NOT INCLUDED IN THE BODY KIT)

### CAB MOUNT KITS

#### 1961-1964:

HEX HEAD	# 6-6053	\$ 60.50
----------	----------	----------

#### 1965-1972:

HEX HEAD	6-6045	85.00
----------	--------	-------

### ENGINE KITS - SEE PAGES 11-14

### FRONT BODY MOUNT KITS

#### 1961-1964:

HEX HEAD	# 6-6025	\$ 12.00
----------	----------	----------

#### 1965-1972:

HEX HEAD	6-6095	15.00
SOCKET HEAD	6-6096	20.00

### FRONT SUSPENSION KITS - 2WD TRUCK

#### 1965-1966:

SIX POINT - HIGH STRENGTH	6-6300	375.00
---------------------------	--------	--------

### REAR SUSPENSION KITS- INCLUDES U-BOLTS!

#### 1965-66:

SIX POINT - HIGH STRENGTH	6-6301	580.00
---------------------------	--------	--------

# BED KITS FOR 1961-66 FORD TRUCKS

**BED KIT** - Every **Styleside** Bed Kit includes component kits for Bed Mount, Tailgate and Tail Lights. **Stepside** Bed Kits include Bed Strip & Side Angles, Rear Bumper, Front Bed Panel, Side Steps, Rear Fenders(Does Both; does NOT contain weld studs or flat top carriage bolts for stepside), Tailgate, License Plate & Tail Light. \*\* NOTE ORIGINAL STYLE INDENTED HEX BOLTS ARE MADE IN USA \*\*

## STEPSIDE BED KITS - 437 PIECES!

BUTTON HEAD	# 6-0268	\$ 165.00
HEX HEAD	6-0269	175.50

## UNIBODY BED KITS

BUTTON HEAD	6-6074	145.00
HEX HEAD	6-6075	145.00
INDENTED HEX HEAD	6-6285	180.00

## STYLESIDE BED KITS - 1957-60

BUTTON HEAD	6-0052	85.00
HEX HEAD	6-0053	85.50

## STYLESIDE BED KITS - 1961-1964:

BUTTON HEAD	# 6-6072	\$ 120.75
HEX HEAD	6-6073	120.00
INDENTED HEX HEAD	6-6286	150.00

## STYLESIDE BED KITS - 1965-1966:

BUTTON HEAD	6-6297	120.25
HEX HEAD	6-6298	120.50
INDENTED HEX HEAD	6-6299	150.50

\*\* NOTE ORIGINAL STYLE INDENTED HEX BOLTS ARE MADE IN USA \*\*

## ACCESSORY KITS

(NOT INCLUDED IN THE BODY KIT)

### STEPSIDE BED MOUNT BOLT - USES 3/8"

BOLTS WITH ORIGINAL STYLE FLANGED CUP WASHERS

BUTTON/FLAT SOCKET/HEX	6-0309	41.75
------------------------	--------	-------

### STYLESIDE REAR BUMPER KITS

-USES 1/2" POLISHED CARRIAGE BOLTS

BUTTON HEAD	6-6058	32.00
HEX HEAD	6-6057	31.00

# BODY KITS FOR 1967-1972 FORD TRUCKS

**BODY KIT** - Every Body kit includes component kits for Battery Box, Windshield Washer Tank, & Relay, Front Bumper(Polished Carriage), Door Hinge, Jambs, Latch & Catch, Front & Inner Fenders, Hood Hinges, Latch & Catch, Interior, Master Cylinder & Steering Column, Radiator Support & Horn, Grill, Gas Tank and Seat Mounting.

Body Kits with Beds also include all appropriate bed component kits listed below under bed kits.

-IF YOU HAVE A FLATBED OR A PANEL TRUCK ORDER A BEDLESS BODY KIT-

## BEDLESS BODY KITS

BUTTON HEAD	# 6-6143	\$ 225.75
HEX HEAD	6-6144	225.00
INDENTED HEX HEAD	6-6146	315.00
ORIGINAL STYLE-INDENTED HEX	6-6168	365.00

WITH BLACK STAINLESS WHERE APPROPRIATE

## BODY KITS WITH STYLESIDE BEDS

BUTTON HEAD	# 6-6150	\$ 280.75
HEX HEAD	6-6151	285.00
INDENTED HEX HEAD	6-6152	385.00
ORIGINAL STYLE-INDENTED HEX	6-6161	430.00

WITH BLACK STAINLESS WHERE APPROPRIATE

## BODY KITS WITH STEPSIDE BEDS

BUTTON HEAD	6-6154	315.00
HEX HEAD	6-6155	320.00

INDENTED HEX HEAD	6-6156	475.00
ORIGINAL STYLE - INDENTED HEX	6-6169	520.00

WITH BLACK STAINLESS WHERE APPROPRIATE

\*\* NOTE INDENTED HEX, & ORIGINAL STYLE BOLTS ARE MADE IN USA \*\*

## DOOR STRIKER BOLTS - ONE PAIR

WITH WASHERS	6-6199	95.50
--------------	--------	-------

## ACCESSORY KITS (NOT INCLUDED IN THE BODY KIT)

### CAB MOUNT KIT

HEX HEAD	6-6045	85.00
----------	--------	-------

### FOLD BACK MIRRORS KIT - DOES BOTH

ORIGINAL STYLE	6-0163	39.00
----------------	--------	-------

### FRONT BODY MOUNT KITS

HEX HEAD	6-6095	15.00
SOCKET HEAD	6-6096	20.00

### FRONT SUSPENSION KIT - 2WD TRUCKS

SIX POINT - HIGH STRENGTH	6-6300	375.00
---------------------------	--------	--------

### REAR SUSPENSION KIT - INCLUDES U-BOLTS!

SIX POINT - HIGH STRENGTH	6-6301	580.00
---------------------------	--------	--------

### STEERING BOX COVER & MOUNT KIT

SIX POINT - HIGH STRENGTH	6-6135	60.00
---------------------------	--------	-------

### ENGINE KITS - SEE PAGES 12-14

**BED KIT** - Every **Styleside** Bed Kit includes component kits for Bed Mount, Tailgate and Tail Lights.

**Stepside** Bed Kits include Bed Strip & Side Angles, Rear Bumper, Front Bed Panel, Side Steps, Rear Fenders(Does Both; does NOT contain weld studs or flat top carriage bolts for stepside), Tailgate, License Plate & Tail Light. \*\* NOTE ORIGINAL STYLE INDENTED HEX BOLTS ARE MADE IN USA \*\*

## STYLESIDE BED KITS

BUTTON HEAD	6-6158	\$ 85.50
HEX HEAD	6-6159	85.00
INDENTED HEX HEAD	6-6160	115.00

## SHORT STEPSIDE BED KITS - 437 PIECES!

BUTTON HEAD	6-0268	165.00
HEX HEAD	6-0269	175.50

\*\* NOTE ORIGINAL STYLE INDENTED HEX BOLTS ARE MADE IN USA \*\*

## ACCESSORY KITS (NOT INCLUDED IN THE BODY KIT)

### STEPSIDE BED MOUNT KIT - USES 3/8" BOLTS WITH ORIGINAL STYLE FLANGED CUP WASHERS

BUTTON/FLAT SOCKET HEAD	6-0309	41.75
-------------------------	--------	-------



# BODY KITS FOR 1973-1979 FORD TRUCKS

**BODY KIT** - Body kits include component kits for Battery Box, Starter Solenoid, & Relay, Front Body Mount, Front Bumper(polished Carriage), Door Hinge, Jambs, Latch & Catch, Front & Inner Fender(does both), Hood Hinges, Latch & Catch, Interior, Jack Mount, Master Cylinder, Radiator Support & Grill, and Seat(for bench seats). Body Kits with Beds also include all appropriate bed component kits listed below.

## BEDLESS BODY KITS

### 1973-1977:

BUTTON HEAD	# 6-6236	\$ 240.50
HEX HEAD	6-6237	240.50
INDENTED HEX HEAD	6-6238	325.00

### 1978-1979:

BUTTON HEAD	6-6239	235.75
HEX HEAD	6-6240	240.75
INDENTED HEX HEAD	6-6241	315.00

## BODY KITS FOR 1978-79 BRONCO:

BUTTON HEAD	6-6254	345.00
HEX HEAD	6-6255	350.25
INDENTED HEX HEAD	6-6256	385.00

## BODY KITS WITH A STEPSIDE BED

### 1973-1977:

BUTTON HEAD	6-6222	380.00
HEX HEAD	6-6223	385.00
INDENTED HEX HEAD	6-6224	465.00

## ACCESSORY KITS (NOT INCLUDED IN THE BODY KIT)

### CAB MOUNT KIT

HEX HEAD	6-0172	25.75
----------	--------	-------

### TAILGATE CABLE BOLTS

SET OF 4 WITH WASHERS	6-6259	106.75
-----------------------	--------	--------

### DOOR STRIKER BOLTS- ONE PAIR

WITH WASHERS	6-6217	95.50
--------------	--------	-------

**BED KIT** - Every **Styleside** Bed Kit includes component kits for Bed Mount, Tailgate, Rear Side Markers & Tail Lights & License Plate. **Stepside** Bed Kits include Bed Strip & Side Angles, Rear Bumper, Front Bed Panel, Side Steps, Rear Fenders(Does Both; does NOT contain weld studs or flat top carriage bolts for stepside), Tailgate, License Plate & Tail Light. \*\* NOTE ORIGINAL STYLE INDENTED HEX BOLTS ARE MADE IN USA \*\*

## STYLESIDE BED KITS

BUTTON/CARRIAGE	6-6230	90.00
HEX/CARRIAGE	6-6231	85.00
INDENTED HEX/CARRIAGE	6-6232	125.00

## BODY KITS WITH A STEPSIDE BED

### 1978:

BUTTON HEAD	# 6-6235	\$ 370.50
HEX HEAD	6-6233	385.75
INDENTED HEX HEAD	6-6234	455.00

## BODY KITS WITH A STYLESIDE BED

### 1973-1977:

BUTTON HEAD	6-6214	310.50
HEX HEAD	6-6215	315.00
INDENTED HEX HEAD	6-6216	399.00

### 1978-1979:

BUTTON HEAD	6-6218	300.75
HEX HEAD	6-6219	310.50
INDENTED HEX HEAD	6-6220	385.00

\*\* NOTE ORIGINAL STYLE INDENTED HEX BOLTS ARE MADE IN USA \*\*

## ENGINE KITS - SEE PAGES 12-14

## FOLD BACK MIRROR KIT - DOES BOTH

ORIGINAL STYLE	6-0163	40.00
----------------	--------	-------

## TAILGATE STRIKER BOLTS

SET OF 2 WITH WASHERS	6-6257	42.00
-----------------------	--------	-------

## STEPSIDE BED KITS - 1973-1979

BUTTON HEAD	6-0268	165.00
HEX HEAD	6-0269	175.50

# BODY KITS FOR 1980-1991 FORD TRUCKS

**BODY KIT** - Body kits include component kits for Battery Box, Starter Solenoid, & Relay, Bed Mount, Front Body Mount, Front Bumper(polished Carriage), Cowl Cover, Door Hinge, Door Jambs, Front & Inner Fender(does both), Gas Pedal, Grill, Hood Hinges, Hood Latch, Interior, Master Cylinder, Radiator Support, and Seat(for bench seats). Body Kits with Styleside Beds also include component kits for Bed Mounts, Tailgate, and Tail Lights.

-IF YOU HAVE A FLATBED OR A PANEL TRUCK ORDER A BEDLESS BODY KIT-

## BEDLESS BODY KITS

### 1980-1986:

BUTTON HEAD	6-2330	215.75
HEX HEAD	6-2331	190.50

### 1987-1991:

BUTTON HEAD	6-2367	245.25
HEX HEAD	6-2368	225.00

## BODY KITS WITH A STYLESIDE BED

### 1980-1984:

BUTTON HEAD	6-2374	325.50
HEX HEAD	6-2375	310.50

### 1985-1986:

BUTTON HEAD	6-2376	315.75
HEX HEAD	6-2377	310.00

### 1987-1991:

BUTTON HEAD	6-2369	345.75
HEX HEAD	6-2370	320.75

## ACCESSORY KITS (NOT INCLUDED IN THE BODY KIT)

### WINDOW TRIM FOR BRONCO/CLUB CAR EXTRA

ORIGINAL STYLE	6-2361	30.00
----------------	--------	-------

### CENTER CONSOLE KIT FOR BRONCO

ORIGINAL STYLE	6-2362	9.00
----------------	--------	------

### CAB MOUNT KIT - HEX HEAD

6-2366	28.75
--------	-------

## ENGINE KITS - SEE PAGES 12-14

### TAILGATE FOR BRONCO

BUTTON HEAD	6-2365	26.00
HEX HEAD	6-2363	26.50
INDENTED HEX HEAD	6-2364	40.00

### BED MOUNT KIT - INCLUDES SPECIAL CARRIAGE HEAD SHOULDER BOLTS

CARRIAGE HEAD	6-2360	139.50
---------------	--------	--------

# KITS FOR 1966-1977 FORD BRONCOS

**BODY KIT**- includes component kits for Battery Box & Horn, Bumpers, Cowl Vent, Door Hinges, Jamb, Latch & Catch, Door Straps, Front Fenders, Heater to Firewall, Hood Hinges, Latch & Catch, Inner Door Panel, Interior, Lenses, Master Cylinder, Radiator Support, Rear Axle Bump Stops, Starter Solenoid & Relay, Front Seats, Steering Column Mount & Bezel, Washer Tank, Tailgate, and Windshield Retaining Bolts.

Contains one of each component kit

BUTTON HEAD	# 6-6500	\$ 230.25
HEX HEAD	6-6501	245.75
ORIGINAL STYLE - INDENTED HEX HEAD	6-6502	305.00

\*\* NOTE INDENTED HEX BOLTS ARE MADE IN USA \*\*

## ACCESSORY KITS (NOT INCLUDED IN THE BODY KIT)

### BODY(CAB) MOUNT KIT

HEX HEAD # 6-6546 \$ 38.75

### FRONT BODY MOUNT KIT

HEX HEAD 6-6560 16.75

### REAR LIFT GATE KITS

BUTTON/FLAT SOCKET HEAD 6-6553 32.00  
PHILLIPS HEAD 6-6554 18.25

### REAR SEAT BOLT KITS

BUTTON HEAD 6-6548 10.50  
HEX HEAD 6-6549 11.00  
INDENTED HEX HEAD 6-6547 13.25

### STEERING BOX MOUNT KIT

SIX POINT 6-6566 65.50

### TOP TO BODY BOLT KITS

BUTTON HEAD # 6-6557 \$ 34.00  
HEX HEAD 6-6558 35.75  
INDENTED HEX HEAD 6-6559 55.00

### REAR SUSPENSION KIT - INCLUDES HIGH

STRENGTH BOLTS & U-BOLTS!

1966-1975: SIX POINT 6-6565 475.00  
1976-1977: SIX POINT 6-6567 480.50

### SPARE TIRE CARRIER KIT

BUTTON HEAD 6-6570 20.00  
HEX HEAD 6-6571 15.00  
INDENTED HEX HEAD 6-6572 25.00

- SEE PAGE 67 FOR 1978-79 FORD BRONCO KITS -

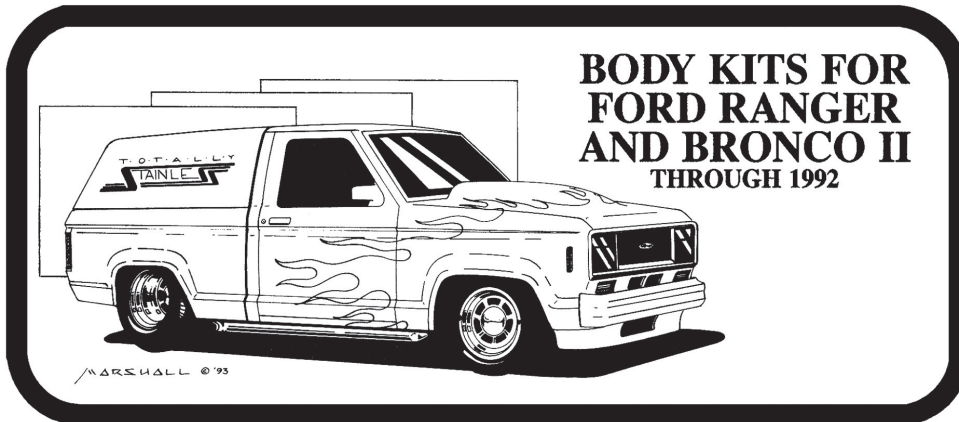

### DOOR HINGES KITS - DOES BOTH!

BUTTON HEAD # 5-0309 \$ 15.00  
HEX HEAD 5-0310 15.50

### DOOR SILL PLATE KIT - DOES BOTH

PHILLIPS HEAD 5-0312 4.00

### FRONT BUMPER KITS

1982-1989:

BUTTON HEAD 5-0321 16.50  
HEX HEAD 5-0322 15.50

1990-1992:

BUTTON HEAD 5-0323 45.00  
HEX HEAD 5-0324 36.75

### FRONT/INNER FENDERS KITS

BUTTON HEAD 5-0318 13.75  
HEX HEAD 5-0319 14.00

### HEADLIGHTS/GRILL & SIGNALS KITS

1982-1989:

PHILLIPS HEAD 5-0325 8.25

1990-1992:

BUTTON/PHILLIPS HEAD 5-0326 21.00  
HEX/PHILLIPS HEAD 5-0327 21.50

### HOOD LATCH & CATCH KITS

BUTTON HEAD # 5-0300 \$ 5.75  
HEX HEAD 5-0301 5.75

### HOOD HINGE KITS - DOES BOTH!

BUTTON HEAD 5-0303 5.25  
HEX HEAD 5-0304 5.25

### RADIATOR SUPPORT KITS

BUTTON HEAD 5-0315 6.75  
HEX HEAD 5-0316 6.75

### REAR GLASS KIT FOR BRONCO II

BUTTON/PHILLIPS HEAD 5-0328 5.75  
HEX/PHILLIPS 5-0329 5.75

### SPARE TIRE CARRIER MOUNT KITS

BUTTON HEAD 5-0320 14.00  
SOCKET HEAD 5-0317 15.00

### TAILGATE KITS

-FLAT SOCKET USED ON HINGE MOUNTS

BUTTON HEAD 5-0313 11.50  
HEX HEAD 5-0314 11.25

**TOLL FREE ORDER LINE : 1-800-767-4781**

## BODY & SUSPENSION KITS FOR CJ5, CJ6, CJ7, CJ8 & WRANGLER



**BODY KIT** - Body Bolt kits include one of each component kit, including: Antenna Mount (73-86), Back Cab Panel (CJ8), Battery Box/Firewall, Body Mount (including big body mount washers!), Front Bumper, Cowl Vent (1972-86 CJ's, Dash, Door Handles, Window Cranks, Door Latches, Strikers, Limiter Strap Bracket(Hardtop & Wrangler), Interior Door Handles (CJ Hardtops), Fenders (does both), Fender Flares (1976-86 CJ's & Wrangler), Front Seat Mounts, Fuel Filler (1976-86 CJ's & Wrangler), Gas Pedal & Steering Column (1976-86 CJ's & Wrangler), Glove Box (55-71), Hard Top Fastener (CJ7, Scrambler, Wrangler), Headlight/Turn Signals, Under Hood Brace Rods, Hood Hinges, Hood Hold Down, Hood Latch & Support Rod, Horn, Overflow Tank & Washer Tank (1972-86 CJ's & Wrangler, includes Jack mount), Jack Bracket (1976-86 CJs), Master Cylinder & Hydraulic Clutch Cylinder (1972-1986 CJs), Mirrors (does 2 door mirrors; all but 87-93 full steel doors on Wrangler), Radiator Mount, Rear Bumper (1976-86 CJs), Rear Corner Braces (Scramblers), Rollbar (76-86), Side Marker Lights (1976-86 CJs), Soft Top Frame (Wrangler), Steering Column Mount, Spare Tire Carrier, Tail Lights (1976-86 CJ's & Wrangler), Tailgate Hinges (CJs), Transmission Cover, Visor (does both Hardtop & Wrangler), Windshield & Door Hinges (1976-86 CJs & Wrangler), Windshield Hinges (does both; 1955-86 CJs), Windshield Hold Down Bracket (CJs), Windshield Washer Jets (Wrangler), and Windshield Latch (does both)!

## BODY KITS FOR CJ5, CJ6, CJ7, CJ8 & WRANGLER:

### 1955-1971 CJ 5 & CJ 6 - 476 PIECES!

BUTTON HEAD	# 6-2464	\$ 260.00
HEX HEAD	6-2465	250.50
ORIGINAL STYLE - INDENTED HEX	6-2466	299.00

### 1972-1975 CJ 5 - WITHOUT TAILGATE - 464 PIECES!

BUTTON HEAD	6-2467	280.25
HEX HEAD	6-2468	285.50
ORIGINAL STYLE - INDENTED HEX	6-2469	335.00

### 1972-1975 CJ 5 & CJ 6 - WITH TAILGATE - 547 PC!

BUTTON HEAD	6-2473	290.25
HEX HEAD	6-2474	310.75
ORIGINAL STYLE	6-2475	355.00

### 1976-1984 CJ 5 - WITHOUT TAILGATE - 640 PIECES!

BUTTON HEAD	6-2476	335.00
HEX HEAD	6-2477	330.00
ORIGINAL STYLE - INDENTED HEX	6-2478	365.00

### 1976-1984 CJ 5 - WITH TAILGATE - 676 PIECES!

BUTTON HEAD	6-2479	350.50
HEX HEAD	6-2480	350.75
ORIGINAL STYLE - INDENTED HEX	6-2481	399.00

### 1976-1986 CJ 7 SOFT TOP - 680 PIECES!

BUTTON HEAD	# 6-2482	\$ 360.00
HEX HEAD	6-2483	350.50
ORIGINAL STYLE - INDENTED HEX	6-2484	385.00

### 1976-1986 CJ 7 HARD TOP - 735 PIECES!

BUTTON HEAD	6-2485	405.75
HEX HEAD	6-2486	395.75
ORIGINAL STYLE - INDENTED HEX	6-2487	435.00

### CJ 8 SCRAMBLER SOFT TOP - 704 PIECES!

BUTTON HEAD	6-2488	380.50
HEX HEAD	6-2489	375.25
ORIGINAL STYLE - INDENTED HEX	6-2490	440.00

### CJ 8 SCRAMBLER HARD TOP - 780 PIECES!

BUTTON HEAD	6-2491	410.00
HEX HEAD	6-2492	400.50
ORIGINAL STYLE - INDENTED HEX	6-2493	470.00

### 1987-1995 WRANGLER SOFT TOP - 731 PCS!

BUTTON HEAD	6-2497	390.75
HEX HEAD	6-2498	380.00
ORIGINAL STYLE - INDENTED HEX	6-2499	435.00

### 1987-1995 WRANGLER HARD TOP - 728 PCS!

BUTTON HEAD	6-2494	400.75
HEX HEAD	6-2495	390.25
ORIGINAL STYLE - INDENTED HEX	6-2496	475.00

\*\* NOTE ORIGINAL STYLE BOLTS ARE MADE IN USA \*\*

**TOLL FREE ORDER LINE : 1-800-767-4781**

**-SEE NEXT PAGE FOR ACCESSORY KITS-**

# ACCESSORY KITS FOR JEEPS

(NOT INCLUDED IN THE BODY KIT)

## AXLE STOP BUMPER MOUNT KITS\*

- FOR 1976-1986 CJs

BUTTON HEAD	# 6-2095	\$ 6.25
HEX HEAD	6-2096	6.75
INDENTED HEX HEAD	6-2097	15.00

## BRAKE & FUEL LINE BRACKETS KITS\*

- FOR 1976-1986 CJs

BUTTON HEAD	6-2076	10.50
HEX HEAD	6-2077	12.00
INDENTED HEX HEAD	6-2078	30.00

## DOOR ASSEMBLY KITS FOR:

CJ HARDTOP	6-2254	27.25
WRANGLER SOFTTOP	6-2255	7.00
WRANGLER HARDTOP	6-2256	19.00

## ENGINE MOUNTS TO FRAME KITS\*

- FOR 1976-1986 CJs STRAIGHT SIX:

SIX POINT - HIGH STRENGTH	6-3561	93.50
TWELVE POINT - HIGH STRENGTH	6-3562	95.00

- FOR 1976-1986 CJs WITH V-8:

SIX POINT - HIGH STRENGTH	6-2259	72.00
TWELVE POINT - HIGH STRENGTH	6-2260	75.00

## ENGINE KITS FOR AMC - SEE PAGES 8-9

## KITS FOR CJ's WITH F134 4 CYLINDERS

ENGINE KIT - HEX HEAD	6-2950	102.50
BELLHOUSING - SIX POINT	6-2960	101.00
TRANSMISSION KIT - SIX POINT	6-2965	12.75
TRANS. TO BELL HOUSING	6-2961	33.00
TRANSFER CASE TO TRANS.	6-2963	18.75
TRANSFER CASE TO FRAME	6-2962	120.50
TRANSFER CASE COVER - HEX	6-2966	22.00
BALL PIVOT FOR CLUTCH MOUNT	6-2964	10.25
PEDALS MOUNTING KIT	6-2049	19.75

## TAILGATE SHOULDER BOLTS FOR CJ

SHOULDER BOLTS & WASHERS	6-2004	170.00
--------------------------	--------	--------

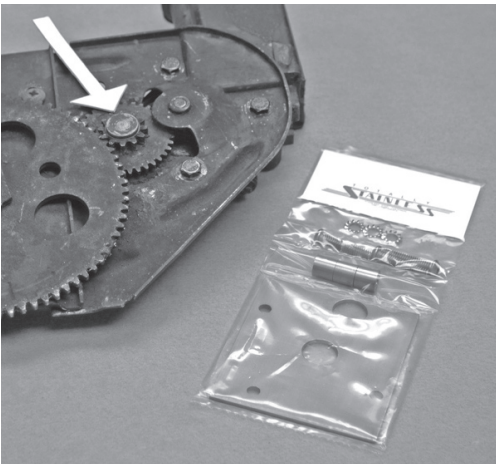

## FRONT SHOCK BRACKET KITS\*

-BOLT ON TYPE - FOR 1976-1986 CJs

SIX POINT - HIGH STRENGTH	# 6-2233	\$ 53.50
TWELVE POINT - HIGH STRENGTH	6-2234	55.00

## GAS TANK GUARD KITS\* - FOR 1976-1986 CJs

BUTTON HEAD	6-2035	12.50
HEX HEAD	6-2036	12.75

## SNAP KIT FOR SOFT TOPS

PHILLIPS HEAD & SNAPS	6-2000	11.50
-----------------------	--------	-------

## SWAY BAR KITS\*

- FOR 1976-1986 CJs

SIX POINT - HIGH STRENGTH	6-2261	70.50
TWELVE POINT - HIGH STRENGTH	6-2262	75.00

## STEERING BOX COVER & MOUNT KITS\*

-FOR 1976-1986 CJs

SIX POINT - HIGH STRENGTH	6-2067	72.00
TWELVE POINT - HIGH STRENGTH	6-2068	76.50

## SUSPENSION KITS\* - HIGH STRENGTH

STAINLESS BOLTS & U-BOLTS WITH COTTER PINS,

\*\*CASTLE NUTS NOT INCLUDED - SEE PAGE 130\*

- FOR 1972-1975 CJ 5 & 1986 WITH DANA 44 REAR:

SIX POINT - HIGH STRENGTH	6-2258	675.00
---------------------------	--------	--------

- FOR 1976-1985 CJs & 1986 WITH AMC 20 REAR:

SIX POINT - HIGH STRENGTH	6-2253	682.50
---------------------------	--------	--------

- FOR WRANGLERS:

SIX POINT - HIGH STRENGTH	6-2257	875.00
---------------------------	--------	--------

## TRANSFER CASE CROSSMEMBER KITS

- FOR 1976-1986 CJs

SIX POINT - HIGH STRENGTH	6-2263	30.50
TWELVE POINT - HIGH STRENGTH	6-2264	32.50

## WOODEN BOARD MOUNT KITS - FOR

SCRAMBLER (CJ-8)

BUTTON HEAD	6-2213	16.50
HEX HEAD	6-2214	16.75

## DOOR STRIKER BOLTS- ONE PAIR (1982 -86 CJ & 1987 - 95 WRANGLER)

WITH WASHERS	6-2098	80.75
--------------	--------	-------

**CHASSIS KIT** - INCLUDES ALL KITS WITH AN \*  
BESIDE THE TITLE - HIGH STRENGTH

SIX POINT - POLISHED	# 6-2276	\$ 999.50
----------------------	----------	-----------

**TAILGATE WINDOW DRIVE SUPPORT**  
FOR WAGONEER ELIMINATES BINDING SO YOU CAN  
USE THE ELECTRIC WINDOW!  
INCLUDES SCREWS, LOCK WASHERS & SPACERS  
# 8-3000 \$ 54.00



TOLL FREE ORDER LINE : 1-800-767-4781



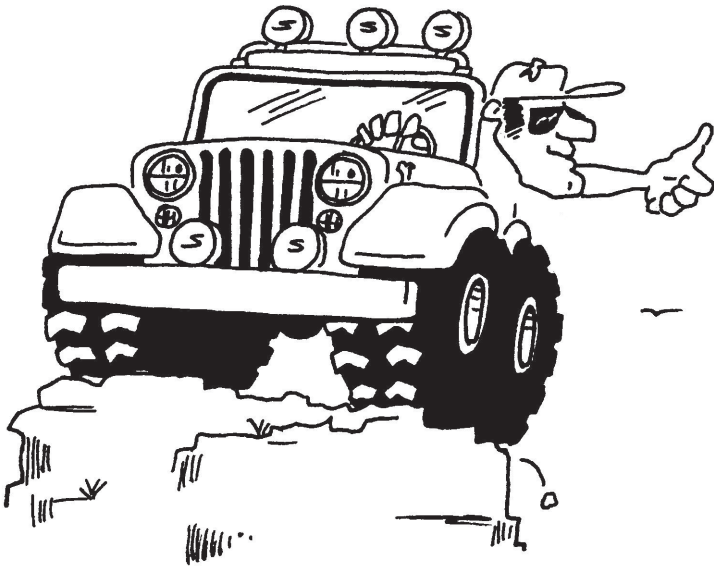

## KITS FOR 1954 NASH METRO

**BODY KIT** - Every Body Kit includes one of each component kit: Bumpers, Bumper Guards, Headlights, Heater & Heater Hose Covers, Heater Fan Mounts, Dash Support, Window Frame, Outer Door Handles, Buttons, & Bezels, Door Hinges, Door Jambs, Window Regulators, Window Stops, Under Dash, Emergency Brake & Cable Guide, Seat Rails to Body(Seat Mounts), Interior, Spare Tire to Body, Wheel Brake Cylinders, Gas Tank, License Plate, Tail Lights, Grill to Body, Radiator to Body, Front Fenders to Body, Hood Hinges, and Trunk Striker to Body.

Contains one of each component kit		
HEX/PHILLIPS HEAD - ORIGINAL STYLE	# 6-9800	\$ 250.00
BUTTON/FLAT SOCKET - CUSTOM STYLE	6-9836	275.00

### ACCESSORY KITS (NOT INCLUDED IN THE BODY KIT)

**CONVERTIBLE TOP KIT WITH SHOULDER BOLTS**  
42 PIECES # 6-9829 \$ 158.50

## BOLT PACKAGES FOR SUNBEAM TIGER

INFORMATION FOR THESE KITS WAS PROVIDED BY MEMBERS OF THE SUNBEAM TIGER CLUB

**839 PC ORIGINAL STYLE BODY KIT: 6-9900 \$250.00**

**149 PC SIX POINT (HIGH STRENGTH) SUSPENSION KIT: 6-9902 \$450.50**

### ACCESSORY KITS (NOT INCLUDED IN THE BODY KIT)

**ENGINE KITS FOR SMALL BLOCK FORD V8 - SEE PAGES 12-13**

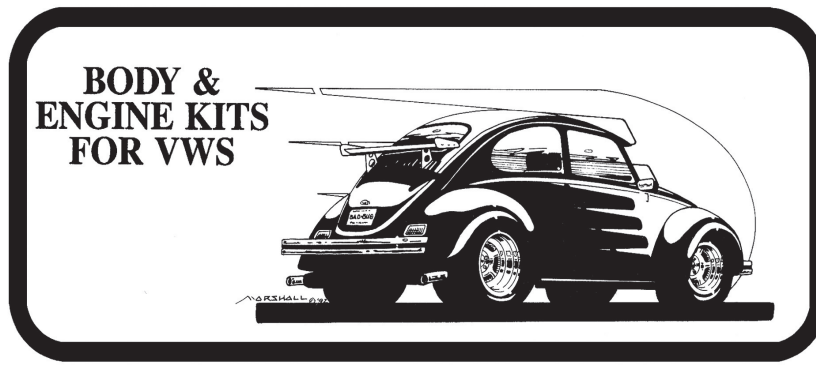

**BODY KITS** - Each body kit includes component kits for: Basic Engine (Includes all bolts to mount your engine components to the long block, from the intake to the generator, does NOT include the case nuts), Brake Cylinder Mount, Bumpers (with polished carriage), Bumper Brackets (does all 4), Deck Lid (hinges, latches & light housing), Door Hinges, Door Jamb, Engine Tin, Exhaust, Fenders (does all 4), Glove Box, Headlight Rings (with turn signal & tail light screws for '67 & earlier), Hood (does both hinges & latches), Oil Plate, License Plate, Pan & Body Mount, Running Board (does both), Shock Mounts, and Turn Signal Switch screws for '67 & up!

### 1966 AND EARLIER KITS

		Price
BUTTON & SOCKET HEAD WITH HEX NUTS	5-0097	\$ 240.50
HEX & CHEESE HEAD & PHILLIPS WITH HEX NUTS	5-0098	225.00
SOCKET HEAD WITH HEX NUTS	5-0099	255.75

### 1967 KITS

BUTTON & SOCKET HEAD WITH HEX NUTS	5-0094	240.00
HEX & CHEESE HEAD & PHILLIPS WITH HEX NUTS	5-0095	225.00
SOCKET HEAD WITH HEX NUTS	5-0096	255.75

### 1968 AND UP KITS

BUTTON & SOCKET HEAD WITH HEX NUTS	5-0091	245.00
HEX & CHEESE HEAD & PHILLIPS WITH HEX NUTS	5-0004	235.50
SOCKET HEAD WITH HEX NUTS	5-0003	260.50

## ACCESSORY KITS (NOT INCLUDED IN THE BODY KIT)

### BACK SEAT PIVOT BOLT KIT (2) SHOULDER BOLTS

BUTTON HEAD	# 5-0062	\$ 92.00
HEX HEAD	5-0063	99.75

### CONVERTIBLE TOP KIT 1956-67 95 PIECES

HEX HEAD & PHILLIPS HEAD (STOCK)	5-0194	60.50
----------------------------------	--------	-------

### FRONT AXLE MOUNTING BOLTS - SET OF 4

- 90 MM LONG BOLTS		
SIX POINT	5-0121	56.50
TWELVE POINT	5-0122	57.75
- 100 MM LONG BOLTS		
SIX POINT - HIGH STRENGTH	5-0087	69.50
12 POINT - HIGH STRENGTH	5-0088	72.00

### HOOD HINGE SHOULDER BOLT KITS

BUTTON HEAD	5-0060	42.00
HEX HEAD (STOCK STYLE)	5-0061	42.00

### OVER RIDER MOUNTS FOR EARLY BUMPERS

HEX HEAD	5-0020	12.00
SOCKET HEAD	5-0021	11.25

### REAR HUB MOUNT BOLT KIT

SIX POINT - HIGH STRENGTH	5-0089	72.50
12 POINT - HIGH STRENGTH	5-0120	75.00

### SPRING PLATE HUB COVER KITS

HEX HEAD	5-0107	28.25
SOCKET HEAD	5-0108	30.50
SIX POINT HEAD (POLISHED)	5-0113	52.50
12 POINT HEAD (POLISHED)	5-0114	55.00

### STEERING BOX KITS - FOR BOXES THAT MOUNT WITH BOLTS (NOT STUDS)

HEX HEAD	# 5-0109	\$ 40.00
SOCKET HEAD	5-0110	44.50
SIX POINT - HIGH STRENGTH	5-0115	95.00
12 POINT - HIGH STRENGTH	5-0116	99.50

### TIE ROD, BUMP STOPS & STABILIZER

HEX HEAD	5-0111	21.75
SOCKET HEAD	5-0112	22.00
SIX POINT - HIGH STRENGTH	5-0117	52.50
12 POINT - HIGH STRENGTH	5-0118	55.00

### TRANSAXLE KITS - ALL OF THE NUTS & WASHERS FOR THE OUTSIDE OF THE CASE

-INDEPENDENT TRANSAXLE KIT: 88 PIECES		
NUTS & WASHERS	5-0101	15.50
-SWINGAXLE TRANSAXLE KIT: 93 PIECES		
NUTS & WASHERS	5-0100	17.50

### TRANSMISSION MOUNT SHOULDER BOLTS - (1) PAIR

BUTTON HEAD	5-0068	65.00
-------------	--------	-------

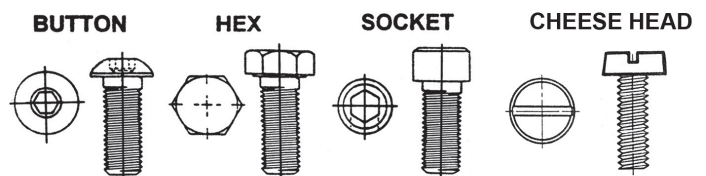

# BODY/ENGINE KITS FOR 1967 & EARLIER VW BUSES

**BODY KIT** - Every Body Kit includes one of each component kit: Basic Engine Kit (everything to mount the Intake, Generator, etc. to the block, does NOT include the case nuts), Bumper Brackets, Engine Tin, Exhaust (for Exhaust Flanges at the Heads & Clamp Bolts & Nuts), Oil Plate (through 1970), Door Hinges (does both front doors), Door Jambs (does both front doors), Engine Compartment Lid, Interior Screws, License Plate, Rear Apron, Rear Bumper, Rear Hatch, and Side Door Hinges & Latches.

Contains one of each component kit

BUTTON & SOCKET HEAD WITH HEX NUTS	# 5-0680	\$ 160.50
HEX & CHEESE & PHILLIPS HEAD WITH HEX NUTS	5-0681	165.50
SOCKET HEAD WITH HEX NUTS	5-0682	170.25

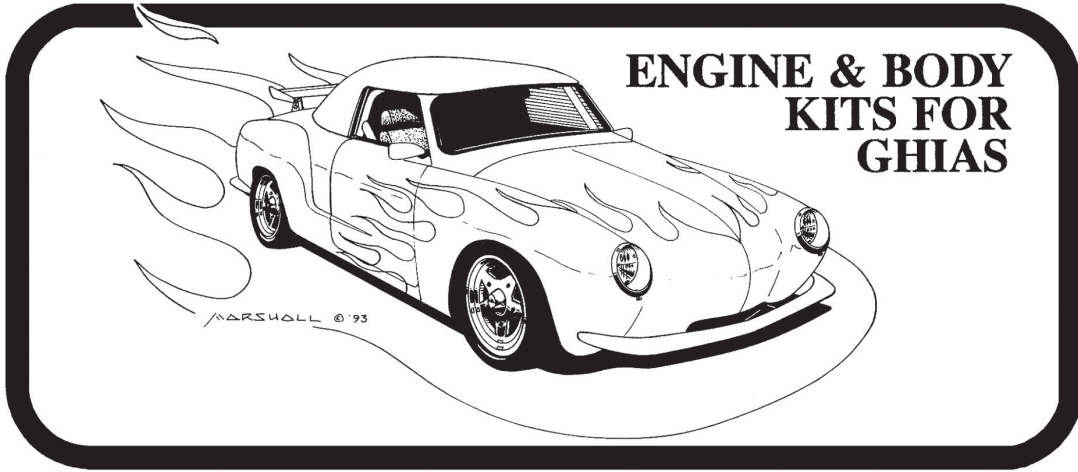

**BODY KITS** - Each Body Kits includes one of each component kit, including: Basic Engine (Includes all bolts to mount your engine components to the long block, from the intake to the generator, does NOT include the case nuts), Bumper Brackets (does all 4), Deck Lid (does both hinges, latches & light housing), Door Hinges, Door Jamb, Engine Tin, Exhaust, Hood (does both hinges & latches), Oil Plate, License Plate, Pan & Body Mount (does complete pan perimeter & body mounts), and Shock Mounts (does both)!

		Price
<b>- INDEPENDENT REAR</b>		
BUTTON & SOCKET HEAD WITH HEX NUTS	# 5-0553	\$ 180.75
HEX & CHEESE HEAD & PHILLIPS WITH HEX NUTS	5-0551	170.75
SOCKET HEAD WITH HEX NUTS	5-0552	185.50
<b>- SWING AXLE REAR</b>		
BUTTON & SOCKET HEAD WITH HEX NUTS	5-0550	185.50
HEX & CHEESE HEAD & PHILLIPS WITH HEX NUTS	5-0548	175.25
SOCKET HEAD WITH HEX NUTS	5-0549	190.00

## ACCESSORY KITS

(NOT INCLUDED IN THE BODY KIT)

### SPRING PLATE HUB COVERS KITS

HEX HEAD	# 5-0107	\$ 28.25
SOCKET HEAD	5-0108	30.50
SIX POINT HEAD (POLISHED)	5-0113	52.50
12 POINT HEAD (POLISHED)	5-0114	55.00

### TRANSAXLE KITS - ALL OF THE NUTS & WASHERS FOR THE OUTSIDE OF THE CASE

-INDEPENDENT TRANSAXLE KIT: 88 PIECES		
NUTS & WASHERS	5-0101	15.50
-SWINGAXLE TRANSAXLE KIT: 93 PIECES		
NUTS & WASHERS	5-0100	17.50



**NEED USED VW PARTS OR SERVICE?  
CALL SAM'S VW SERVICE: 803-359-7289**

## KITS FOR HARLEY V-TWINS

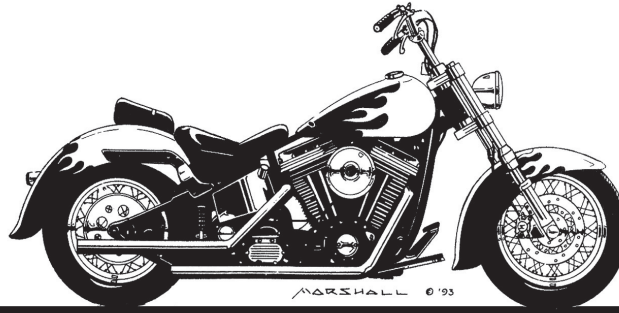

### COMPLETE KIT FOR :

**2000-2006 SOFT TAIL (FAT BOY HERITAGE):** Contains 29 kits for your FLST  
from the front rotor to the back rotor/sprocket.

**PRICE:**

ORIGINAL STYLE

# 4-0220

\$ 525.00

### ENGINE KITS FOR:

**88 TWIN:** Contains kits for the crankcase, tappet blocks, air cleaner, oil filter housing, electronic module, rocker covers and starter cover.

BUTTON/SOCKET HEAD	4-0288	56.00
--------------------	--------	-------

**EVO:** Contains high crown acorn nuts for the case bolts, oil pump(bolts, cover screws: check, relief, & lifter screen plugs), tappet guide screws, gear case cover screws, and rocker cover screws.

SOCKET HEAD & SIX POINT	4-0300	80.25
SOCKET HEAD & TWELVE POINT	4-0301	81.75
SIX POINT-POLISHED - HIGH STRENGTH	4-0302	125.50
TWELVE POINT-POLISHED - HIGH STRENGTH	4-0303	130.00

**SHOVEL HEAD:** Contains lock nuts or high crown acorn nuts for the case bolts, oil pump(bolts, cover screws: check, relief & lifter screen plugs), tappet guide screws, gear case cover screws, rocker cover lock nuts or high crown acorn nuts, cylinder base lock nuts or high crown acorn nuts, and head bolts!

SIX POINT - POLISHED - HIGH STRENGTH	WITH LOCK NUTS	4-0304	160.50
	WITH HIGH CROWN ACORN NUTS	4-0306	250.00
TWELVE POINT - POLISHED - HIGH STRENGTH	WITH LOCK NUTS	4-0305	175.00
	WITH HIGH CROWN ACORN NUTS	4-0307	255.50

### COVER KITS (XL) SPORTSTER:

**-1977-1985:** Contains screws for; primary, crankcase gear, sprocket covers, & oil level screw.

SOCKET HEAD	4-0007	17.00
-------------	--------	-------

**-1991-2003:** Contains screws for; primary, crankcase gear, sprocket, derby, and inspections covers.

SOCKET HEAD	4-0009	19.00
-------------	--------	-------

## STAINLESS COMPONENT KITS

### CYLINDER BASE NUT KITS - 1948-1984

HIGH CROWN ACORN NUTS	# 4-0063	\$ 42.00
NYLON NUTS	4-0065	12.00

### ENGINE MOUNT KITS FOR:

#### -FL/FLH 1948-84 - UPPER & LOWER

SIX POINT - HIGH STRENGTH	4-0019	30.50
TWELVE POINT - HIGH STRENGTH	4-0021	32.50

**-FLT & FXR** - Includes upper stabilizer bolts, nuts for engine bracket, lower mount bolts, and washers

#### -FLT 1987

SIX POINT - HIGH STRENGTH	4-0023	32.50
TWELVE POINT - HIGH STRENGTH	4-0025	35.00

#### -FLT 1988-1989

SIX POINT - HIGH STRENGTH	4-0027	37.50
TWELVE POINT - HIGH STRENGTH	4-0028	39.00

#### -FLT 1991

SIX POINT - HIGH STRENGTH	4-0031	28.50
TWELVE POINT - HIGH STRENGTH	4-0033	30.00

#### -FLT 1993-1994

SIX POINT - HIGH STRENGTH	4-0035	29.50
TWELVE POINT - HIGH STRENGTH	4-0036	32.50

### ENGINE MOUNT KITS FOR: (CONTINUED)

#### -FXR 1984-1987

SIX POINT - HIGH STRENGTH	# 4-0039	\$ 29.50
TWELVE POINT - HIGH STRENGTH	4-0041	30.00

#### -FXR 1988-1989

SIX POINT - HIGH STRENGTH	4-0043	30.50
TWELVE POINT - HIGH STRENGTH	4-0045	32.50

#### -FXR 1991-1994

SIX POINT - HIGH STRENGTH	4-0047	38.50
TWELVE POINT - HIGH STRENGTH	4-0048	40.00

**SOFT TAIL:** Includes upper & lower bolts, nut & washers.

#### -1984-1989

SIX POINT - HIGH STRENGTH	4-0051	30.50
TWELVE POINT - HIGH STRENGTH	4-0053	32.50

#### -1991

SIX POINT - HIGH STRENGTH	4-0055	35.00
TWELVE POINT - HIGH STRENGTH	4-0057	38.50

#### -1993-1997

SIX POINT - HIGH STRENGTH	4-0059	36.50
TWELVE POINT - HIGH STRENGTH	4-0061	39.00

#### -2000-2006

SIX POINT - HIGH STRENGTH	4-0233	50.50
---------------------------	--------	-------



## COMPONENT KITS FOR HARLEY V-TWINS CONTINUED:

### GEARCASE/GENERATOR FOR

<b>-FL, FLH 1941-1969:</b> SPECIAL 1/4-24 SOCKET WITH CORRECT 60 DEGREE TAPER HEADS - SUPER TRICK!		
POLISHED SOCKET HEAD	# 4-0212	\$ 80.00

### GEAR & TIMING COVERS FOR

#### -ALL SHOVEL HEAD AND EVO ENGINES

BUTTON HEAD	4-0076	7.00
SOCKET HEAD	4-0078	7.00
SIX POINT - HIGH STRENGTH	4-0079	20.50
TWELVE POINT - HIGH STRENGTH	4-0081	25.00

### HANDLE BAR SWITCHES SCREW KITS FOR

#### -LATE SHOVEL HEAD

SOCKET HEAD	4-0070	4.50
-------------	--------	------

#### -EVO

THRU 1994 SOCKET HEAD	4-0072	3.00
1995-1997 SOCKET HEAD	4-0254	3.00
1998-2004 BOTTON HEAD	4-0255	3.00

### HEAD BOLTS KITS - FOR 1966-1984 SHOVELHEAD

SIX POINT - HIGH STRENGTH	4-0074	62.50
TWELVE POINT - HIGH STRENGTH	4-0310	65.00

### OIL PUMP BOLT KITS FOR

#### -1980-1996 SHOVEL HEAD AND EVO ENGINES

SIX POINT - HIGH STRENGTH	4-0084	22.50
TWELVE POINT - HIGH STRENGTH	4-0086	25.00

### OIL PUMP PLUG SCREWS - CHECK, RELIEF

VALVE, & LIFTER SCREEN PLUGS FOR 1979 & UP		
SET OF 3 POLISHED	4-0068	35.00

### PRIMARY COVERS FOR

#### -FL, FLH 1955-1964

SOCKET HEAD	4-0088	5.00
-------------	--------	------

#### -2011 & UP STREET GLIDE

SOCKET HEAD	4-0294	30.00
-------------	--------	-------

### PRIMARY, DERBY, & INSPECTION COVERS

#### -FOR FL, FLH, FLH-80 1970-1980

SOCKET HEAD	4-0090	12.00
-------------	--------	-------

#### -FOR FL, FLH 1981-1984

SOCKET HEAD	4-0092	12.00
-------------	--------	-------

#### -FOR FLH-80 1981-1982

SOCKET HEAD	4-0094	12.00
-------------	--------	-------

#### -FOR CLASSIC 1981-1982

SOCKET HEAD	4-0096	12.00
-------------	--------	-------

#### -FOR FLT 1987-1996

BUTTON HEAD	4-0108	12.00
SOCKET HEAD	4-0110	12.00
SIX POINT - HIGH STRENGTH	4-0112	42.50
TWELVE POINT - HIGH STRENGTH	4-0113	45.50

#### -FOR FLHT 1998 & UP

BUTTON & SOCKET HEAD	4-0311	9.50
----------------------	--------	------

#### -FOR FXR 1984-1994

BUTTON HEAD	4-0100	12.00
SOCKET HEAD	4-0102	12.00
SIX POINT - HIGH STRENGTH	4-0104	46.00
TWELVE POINT - HIGH STRENGTH	4-0106	50.00

#### -FOR SOFT TAIL 1984-1988

BUTTON HEAD	4-0116	12.00
SOCKET HEAD	4-0118	12.00
SIX POINT - HIGH STRENGTH	4-0120	46.00
TWELVE POINT - HIGH STRENGTH	4-0122	50.50

#### -FOR SOFT TAIL 1989-1999

BUTTON HEAD	4-0124	12.00
SOCKET HEAD	4-0126	12.00
SIX POINT - HIGH STRENGTH	4-0128	45.50
TWELVE POINT - HIGH STRENGTH	4-0130	50.00

#### -FOR SOFT TAIL 2000-2006

BUTTON/SOCKET HEAD	4-0229	9.75
--------------------	--------	------

#### -FOR DYNA 1991-1996

BUTTON HEAD	4-0132	12.00
SOCKET HEAD	4-0134	12.00
SIX POINT - HIGH STRENGTH	4-0136	46.50
TWELVE POINT - HIGH STRENGTH	4-0138	50.50

### REAR SPROCKET FOR

#### -1999 & EARLIER FXR & SOFT TAIL

SIX POINT - HIGH STRENGTH	# 4-0261	\$ 26.50
---------------------------	----------	----------

#### -2000 & UP SOFT TAIL

SIX POINT - HIGH STRENGTH	4-0251	29.00
---------------------------	--------	-------

### ROCKER BOXES KITS FOR

#### -FL, FLH, PAN HEAD 1948-1965

SOCKET HEAD	4-0140	33.00
-------------	--------	-------

#### -SHOVEL HEAD 1966-1984

HIGH CROWN ACORN	4-0142	59.50
NYLON LOCK NUTS	4-0144	22.00
STANDARD ACORN	4-0146	32.00

#### -EVO

BUTTON HEAD	4-0148	5.00
SOCKET HEAD	4-0150	5.00
SIX POINT - HIGH STRENGTH	4-0152	19.50
TWELVE POINT - HIGH STRENGTH	4-0154	22.50

### TAPPET GUIDE KITS FOR

#### -PAN HEAD 1955-1965, FLH - 1/4-24 SOCKET!

POLISHED SOCKET HEAD	4-0155	40.00
----------------------	--------	-------

#### SHOVEL HEAD, EVO, & 88 TWIN (1967 & UP)

BUTTON HEAD	4-0160	5.00
SOCKET HEAD	4-0162	5.00
SIX POINT - HIGH STRENGTH	4-0164	19.50
TWELVE POINT - HIGH STRENGTH	4-0166	22.50

### TIMING PLUG FOR - STOCK SIZE

#### -1941-1969 PAN HEAD

POLISHED	4-0213	12.00
----------	--------	-------

#### -1970 & UP THRU EVO

POLISHED	4-0167	20.50
----------	--------	-------

### TRANSMISSION, SIDE COVER FOR

#### -FL, FLH 1941-1969

HIGH CROWN ACORN	4-0169	22.00
STANDARD ACORN	4-0171	10.00

### TRANSMISSION, SIDE COVER, TOP COVER, BEARING HOUSING FOR

#### -FLT, FXR, SOFT TAIL 1984-1989

BUTTON HEAD	4-0173	14.00
SOCKET HEAD	4-0175	12.00
SIX POINT - HIGH STRENGTH	4-0177	45.00
TWELVE POINT - HIGH STRENGTH	4-0179	49.50

#### -FLT, FXR, SOFT TAIL 1991-1992

BUTTON HEAD	4-0181	19.00
SOCKET HEAD	4-0183	15.00
SIX POINT - HIGH STRENGTH	4-0185	55.00
TWELVE POINT - HIGH STRENGTH	4-0187	60.50

#### -FLT 1993-1996

BUTTON HEAD	4-0189	15.00
SOCKET HEAD	4-0191	15.00
SIX POINT - HIGH STRENGTH	4-0193	52.50
TWELVE POINT - HIGH STRENGTH	4-0195	55.00

#### -FXR 1993-1996

BUTTON HEAD	4-0197	14.00
SOCKET HEAD	4-0199	12.00
SIX POINT - HIGH STRENGTH	4-0201	38.50
TWELVE POINT - HIGH STRENGTH	4-0203	40.50

#### -SOFT TAIL 1993-1999

BUTTON HEAD	4-0205	14.00
SOCKET HEAD	4-0207	12.00
SIX POINT - HIGH STRENGTH	4-0209	38.50
TWELVE POINT - HIGH STRENGTH	4-0211	40.50

#### -SOFT TAIL 2000-2006

SOCKET HEAD	4-0234	10.00
-------------	--------	-------

### TRANSMISSION TOP COVER FOR

#### -FL, FLH 1965-EARLY 1979 - SPECIAL 1/4-24 SOCKETS!

POLISHED SOCKET	4-0214	56.00
-----------------	--------	-------

### TRANSMISSION SIDE & TOP COVER

#### -2008 & UP STREET GLIDE SIX SPEED

BUTTON HEAD	4-0370	10.50
SOCKET HEAD	4-0371	12.50
SIX POINT - HIGH STRENGTH	4-0372	62.50
TWELVE POINT - HIGH STRENGTH	4-0373	67.00

# SHOP ASSORTMENTS

SHOP ASSORTMENTS HAVE A 16 OR 24 COMPARTMENT METAL BOX WITH A LIST OF CONTENTS, INCLUDING PART NUMBERS FOR EASY REORDER!

## MASTER SHOP ASSORTMENTS:

### -STREET RODDER SPECIAL: 9,000 PIECES!

CONTAINS (1) EACH OF THE BUTTON, FLAT SOCKET, SOCKET, LOCK NUT/FLAT WASHER, PHILLIPS TRUSS AND, PHILLIPS OVAL SHEET METAL ASSORTMENTS. ALSO INCLUDES THE 6 DRAWER CABINET!  
# 3-3090 \$ 1865.50

### -RESTORER'S SPECIAL: 9,170 PIECES!

CONTAINS (1) EACH OF THE INDENTED HEX HEAD, INDENTED HEX WASHER HEAD, PHILLIPS OVAL, NUT/LOCK/WASHER, PHILLIPS OVAL SHEET METAL (WITH JACKSON HEADS), AND PHILLIPS TRUSS SHEET METAL ASSORTMENTS. ALSO INCLUDES THE 6 DRAWER CABINET!  
3-3091 3071.75

### BOLTS - COURSE THREAD - 16 SIZES RANGING FROM 10-24 X 1/2 THROUGH 3/8-16 X 2 EXCEPT AS NOTED:

BUTTON CAP	635 PC	3-3003	255.50
24 SIZES: 6-32 X 3/8 TO 3/8-16 X 1 1/2	1500 PC	3-3062	287.50
CARRIAGE	515 PC	3-3008	240.50
FLAT SOCKET	635 PC	3-3020	240.00
24 SIZES: 6-32 X 3/8 TO 3/8-16 X 1 1/2	1500 PC	3-3060	260.50
HEX CAP	635 PC	3-3002	295.00
INDENTED HEX	700 PC	3-3017	829.30
INDENTED HEX - BLACK & FLATS	700 PC	3-3016	1021.50
INDENTED HEX WASHER HEAD	600 PC	3-3059	1010.25
SOCKET CAP	635 PC	3-3004	420.75
SIX POINT - POLISHED - HIGH STRENGTH	400 PC	3-3014	1883.50
TWELVE POINT - POLISHED - H.S.	400 PC	3-3015	2019.90

### BOLTS - FINE THREAD - 16 SIZES: 10-32 X 1/2 TO 3/8-24 X 1 1/2

BUTTON CAP	635 PC	3-3042	360.50
HEX CAP	635 PC	3-3018	340.00
SOCKET CAP	635 PC	3-3019	347.50
FLAT SOCKET	665 PC	3-3041	351.00
SIX POINT - POLISHED - HIGH STRENGTH	388 PC	3-3069	1838.60
TWELVE POINT - POLISHED - H.S.	388 PC	3-3071	1938.60

### MACHINE SCREWS - 24 SIZES: 6-32 X 3/8 TO 5/16-18 X 1

FILLISTER - SLOTTED	1720 PC	3-3055	302.50
FLAT - PHILLIPS	1720 PC	3-3027	211.00
FLAT - SLOTTED	1720 PC	3-3028	310.75
METRIC PHIL. FLAT: 4 X 6 TO 8 X 30	1720 PC	3-3082	311.50
OVAL - PHILLIPS	1720 PC	3-3029	261.75
OVAL - SLOTTED	1720 PC	3-3030	380.50
METRIC PHIL. OVAL: 4 X 6 TO 8 X 30	1720 PC	3-3072	311.25
PAN - PHILLIPS	1720 PC	3-3031	220.50
PAN - SLOTTED	1720 PC	3-3032	307.50
METRIC PHIL. PAN: 4 X 6 TO 8 X 30	1720 PC	3-3068	311.50
ROUND - PHILLIPS	1720 PC	3-3033	202.50
ROUND - SLOTTED	1720 PC	3-3056	347.75
TRUSS - PHILLIPS	1720 PC	3-3034	242.75
TRUSS - SLOTTED	1720 PC	3-3057	351.50

### NUTS, FLAT & LOCK WASHER, & LOCK NUTS

#### HEX NUTS, LOCKS & FLATS - 16 SIZES EXCEPT AS NOTED:

COARSE THREAD: 10-24 TO 3/8-16	2200 PC	3-3005	204.75
24 SIZES: 6-32 TO 3/8-16	3400 PC	3-3061	219.50
FINE THREAD: 10-32 TO 3/8-24	2200 PC	3-3021	185.50
METRIC THREAD: 5-0.8 TO 10-1.5	2000 PC	3-3013	185.00

#### METRIC NUTS, LOCK NUTS, FLAT & LOCK WASHERS

24 SIZES: 5MM - 12MM A2-70	1707 PC	3-3080	170.25
----------------------------	---------	--------	--------

#### LOCK NUTS & FLATS:

24 SIZES: 6-32 TO 3/8-16	3475 PC	3-3063	276.50
--------------------------	---------	--------	--------

#### NUT ASSORTMENT - ACORN/HEX/LOCK NUT/WING

COARSE THREAD: 10-24 TO 3/8-16	1010 PC	3-3010	265.00
FINE THREAD: 10-32 TO 3/8-24	1220 PC	3-3022	276.50

#### NUT ASSORTMENT - ACORN/HEX/JAM & NYLON LOCKS - 24

COARSE THREAD: 10-24 TO 1/2-13	1167 PC	3-3075	315.50
FINE THREAD: 10-32 TO 1/2-20	1062 PC	3-3076	315.50

#### NUT ASSORTMENT - HEX/JAM/FLANGE & NYLON LOCKS

METRIC THREAD: 5-0.8 TO 10-1.5	1375 PC	3-3067	210.00
--------------------------------	---------	--------	--------

#### NYLON INSERT LOCK NUTS

COARSE THREAD: 6-32 TO 1/2-13	1460 PC	3-3037	275.50
FINE THREAD: 10-32 TO 1/2-20	900 PC	3-3070	304.75

#### WASHERS

FLAT WASHERS: #10 TO 3/8	1705 PC	3-3009	155.00
24 SIZES: #10 TO 1/2	2250 PC	3-3066	178.00
LOCK WASHERS: #10 TO 3/8	1705 PC	3-3035	156.00
#6 TO 3/8	3105 PC	3-3078	197.00
FLAT & TRIM WASHERS - METRIC			
5MM-12MM A2-70	2050 PC	3-3081	178.00

### BOLTS - METRIC THREAD - 16 SIZES: 5-8 X 12 TO 10-1.5 X 40

BUTTON CAP	640 PC	# 3-3048	\$ 292.00
FLAT SOCKET CAP	600 PC	3-3085	292.00
HEX CAP	620 PC	3-3011	286.50
A4-80 HEX CAP	400 PC	3-3098	655.00
SOCKET CAP	640 PC	3-3012	305.00
A4-80 SOCKET	400 PC	3-3099	670.00

### BUTTON SHEET METAL SCREWS - #8 X 3/8 THRU #14 X 1 WITH LARGE OD FLAT WASHERS

1280 PC	3-3092	308.25
---------	--------	--------

### PHILLIPS SHEET METAL SCREWS - 16 SIZES:

FLAT # 6 X 3/8" TO #14 X 1 1/2:	1210 PC	3-3025	184.00
OVAL # 6 X 3/8" TO #14 X 1 1/2:	1210 PC	3-3007	225.50
OVAL W/ (8) JACKSON HEAD SCREW SIZES:			
#8 X 1/2 TO #10 TO 1 1/4 (24 SIZES)	1540 PC	3-3040	330.50
PAN # 6 X 3/8" TO #14 X 1 1/2:	1210 PC	3-3006	233.50
TRUSS # 6 X 3/8" TO #14 X 1 1/2:	1210 PC	3-3026	193.00
BLACK STAINLESS SCREWS - 24 SIZES	1760 PC	3-3089	604.00

### SLOTTED SHEET METAL SCREWS

- 16 SIZES: # 6 X 3/8" TO #14 X 1 1/2"

FLAT	1210 PC	3-3044	317.75
HEX WASHER	1000 PC	3-3036	255.50
OVAL	1210 PC	3-3039	330.75
PAN	1210 PC	3-3043	319.50
TRUSS	1210 PC	3-3058	322.50

### COTTER PIN SHOP SIZE ASSORTMENT

16 SIZES: 3/32 X 1/2 TO 3/16 X 2	1290 PC	3-3049	189.25
24 SIZES: 1/16 X 1/2 TO 1/4 X 2	2175 PC	3-3038	240.50

### LINE CLAMP ASSORTMENT - 237 LINE CLAMPS WITH FLEX

LINE BRACKETS AND CLIPS	249 PC	3-3097	1095.80
-------------------------	--------	--------	---------

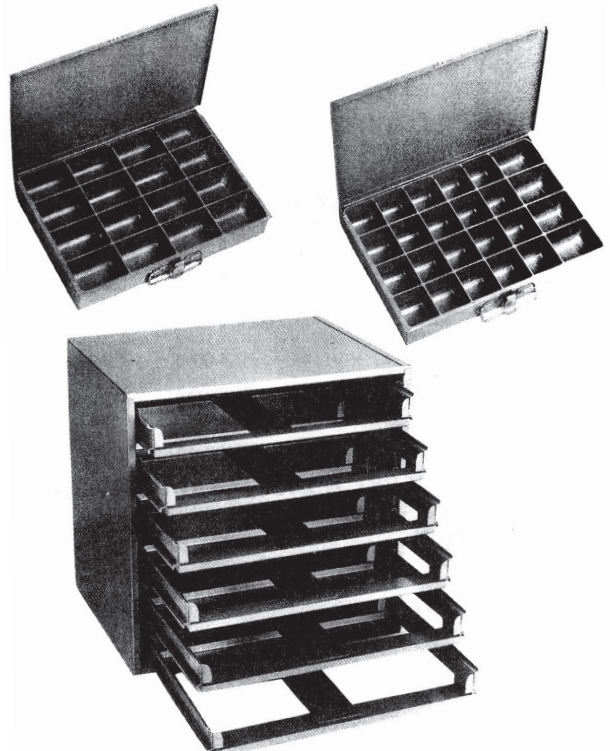

### BOXES & METAL CABINETS MADE IN THE USA!

12 COMPARTMENT	# 3-3123	\$ 49.50
16 COMPARTMENT	3-3000	49.50
24 COMPARTMENT	3-3124	49.50
4 DRAWER CABINET	3-3001	171.50
6 DRAWER CABINET	3-3100	250.00

**SPECIAL!!! BUY 4 ASSORTMENTS & GET THE 4 DRAWER CABINET FREE!!**  
**BUY 6 ASSORTMENTS AND GET THE 6 DRAWER CABINET FREE!!**

# PERSONAL ASSORTMENTS

**PERSONAL ASSORTMENTS** - EACH PERSONAL AUTOMOTIVE ASSORTMENT HAS A 18 COMPARTMENT PLASTIC BOX WITH A LIST OF CONTENTS, INCLUDING PART NUMBERS FOR EASY REORDER!

**BOLTS - COARSE THREAD:** 8-32 X 3/8 TO 3/8-16 X 1 1/2"

BUTTON CAP	500 PC	# 3-3150	\$ 127.75
FLAT SOCKET	500 PC	3-3155	132.50
HEX CAP	500 PC	3-3151	174.00
INDENTED HEX - OEM STYLE	500 PC	3-3152	393.00
INDENTED HEX WASHER HEAD	350 PC	3-3165	570.50
BLACK INDENTED HEX	400 PC	3-3142	575.45
SOCKET CAP	500 PC	3-3153	161.50
SIX POINT (POLISHED): HIGH STRENGTH	250 PC	3-3137	1142.50
TWELVE POINT	250 PC	3-3138	1230.50

**BOLTS - FINE THREAD:** 10-32 X 3/8 TO 3/8-24 X 1 1/2"

BUTTON HEAD	400 PC	3-3185	130.00
FLAT SOCKET	400 PC	3-3182	131.00
HEX CAP	400 PC	3-3186	184.00
SOCKET CAP	400 PC	3-3156	164.00

**BOLTS - METRIC THREAD:** 5-0.8 X 12 TO 10-1.5 X 35 MM

BUTTON CAP	400 PC	3-3190	130.00
FLAT SOCKET	400 PC	3-3191	175.00
HEX CAP	400 PC	3-3192	130.00
SOCKET CAP	400 PC	3-3193	155.00

**MACHINE SCREWS** - 6-32 X 3/8 TO 1/4-20 X 1"

FILLISTER - SLOTTED	850 PC	3-3157	148.00
FLAT - PHILLIPS	850 PC	3-3158	130.00
FLAT - SLOTTED	850 PC	3-3171	153.00
OVAL - PHILLIPS	850 PC	3-3166	118.90
OVAL - SLOTTED	850 PC	3-3172	157.00
OVAL - METRIC 3-0.5 X 8 TO 8-1.25 X 25	850 PC	3-3197	177.00
PAN - PHILLIPS	850 PC	3-3167	130.00
PAN - SLOTTED	850 PC	3-3173	155.00
PAN - METRIC 3-0.5 X 8 TO 8-1.25 X 25	850 PC	3-3199	205.00
ROUND - PHILLIPS	850 PC	3-3174	130.00
ROUND - SLOTTED	850 PC	3-3175	170.00
SOCKET SET SCREWS 4-40 TO 3/8-16	345 PC	3-3141	130.00
TRUSS - PHILLIPS	850 PC	3-3168	130.00
TRUSS - SLOTTED	850 PC	3-3164	148.00

**NUTS, FLAT, & LOCK WASHERS**

HEX NUTS, LOCK & FLAT WASHERS:

COARSE THREAD	1200 PC	3-3154	96.25
FINE THREAD	1200 PC	3-3188	95.00
METRIC THREAD	1200 PC	3-3194	95.00

LOCK NUTS & FLATS

COARSE THREAD 8-32 THRU 7/16-14	1077 PC	3-3206	106.00
---------------------------------	---------	--------	--------

LOCK NUTS, LOCK WASHERS & FLATS:

COARSE THREAD	1200 PC	3-3052	107.75
FINE THREAD	1200 PC	3-3189	108.50
METRIC THREAD	1200 PC	3-3195	108.00

FLAT WASHER

#8 TO 7/16"	1200 PC	3-3200	94.00
-------------	---------	--------	-------

V-TWIN SPECIAL: FINE LOCK NUTS/HIGH COLLAR LOCKS/FLATS

8-32 TO 3/8-24	1335 PC	3-3053	115.00
----------------	---------	--------	--------

NUTS/LOCK NUTS/THIN LOCK NUTS: FINE THREAD

10-32 TO 1/2-20	700 PC	3-3187	186.00
-----------------	--------	--------	--------

**SPECIAL!!** BUY 5 ASSORTMENTS & GET THE 5 SHELF CABINET FREE!!

**MASTER SHOP ASSORTMENTS:**

**- STREET RODDER SPECIAL: 3,700 PIECES!**  
CONTAINS (1) EACH OF THE BUTTON HEAD, FLAT SOCKET, SOCKET, NYLON LOCK NUT/FLAT WASHER, AND PHILLIPS OVAL SHEET METAL ASSORTMENTS. ALSO INCLUDES THE 5 SHELF CABINET!  
# 3-3169 \$ 687.75

**- RESTORER'S SPECIAL: 3,900 PIECES!**  
CONTAINS (1) EACH OF THE INDENTED HEX HEAD, INDENTED HEX WASHER, PHILLIPS OVAL, NUT/LOCK/WASHER, AND PHILLIPS OVAL SHEET METAL ASSORTMENTS. ALSO INCLUDES THE 5 SHELF CABINET!  
3-3170 1450.50



**SHEET METAL SCREWS: #6 X 3/8 TO #14 X 1 1/2**

BUTTON - #8 X 3/8 - #14 X 1 W/ WASHERS	1270 PC	3-3139	255.00
FLAT - PHILLIPS	1000 PC	3-3176	113.00
FLAT - SLOTTED	1000 PC	3-3177	154.00
OVAL - PHILLIPS	1000 PC	3-3159	112.75
OVAL - PHILLIPS ALSO INCLUDING JACKSON HEAD TRIM SCREWS	1000 PC	3-3161	214.10
OVAL - SLOTTED	1000 PC	3-3163	190.00
PAN - PHILLIPS	1000 PC	3-3178	113.00
PAN - SLOTTED	1000 PC	3-3179	180.00
ROUND - PHILLIPS	1000 PC	3-3180	113.00
ROUND - SLOTTED	1000 PC	3-3181	160.00
TRUSS - PHILLIPS	1000 PC	3-3160	125.50
TRUSS - SLOTTED	1000 PC	3-3162	169.00

**COTTER PIN PERSONAL SIZE ASSORTMENT**

- 1/16 X 1/2 THROUGH 3/16 X 1 1/2	1000 PC	3-3140	119.00
-----------------------------------	---------	--------	--------

**LINE CLAMP:** 104 CLAMPS WITH BUTTON HEAD SHEET METAL & MACHINE SCREWS 3-3201 644.00

**BOXES & CABINETS** MADE IN THE USA!!  
18 COMPARTMENT PLASTIC BOX # 3-3051 \$ 17.00  
5 SHELF CABINET 3-3105 92.50



**TOLL FREE ORDER LINE : 1-800-767-4781**





# METRIC SIX POINT (SMALL HEX)

HIGH STRENGTH- EQUIVALENT TO METRIC GRADE 10.9 - POLISHED  
MADE IN USA

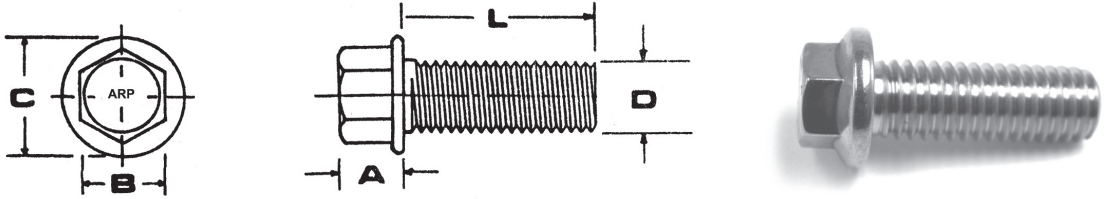

**DIMENSION TABLE (MILLIMETERS)**

D	DIAMETER	6	8	10	10	12	12
	PITCH	1.0	1.25	1.5	1.25	1.75	1.5
A	HEAD HT.	6.4	7.4	9.3	9.3	11.7	11.7
B	WRENCH	8	10	12	12	14	14
C	FLANGE	13	15	18	18	21.6	21.6

**PART NUMBER AND PRICE GUIDE**

DIAMETER	6		8		10-1.5		10-1.25		12-1.75		12-1.5	
LENGTH	PART #	\$	PART #	\$	PART #	\$	PART #	\$	PART #	\$	PART #	\$
12	1-2206	4.67										
16	1-2208	4.80	1-2231	5.37								
20	1-2210	4.95	1-2233	5.50	1-2262	6.00	1-2462	6.00				
25	1-2211	5.05	1-2234	5.90	1-2263	6.35	1-2463	6.36	1-2282	9.27	1-2482	9.27
30	1-2212	5.22	1-2235	6.21	1-2264	7.07	1-2464	7.07	1-2283	9.52	1-2483	9.52
35	1-2213	7.55	1-2236	8.21	1-2265	9.58	1-2465	9.58	1-2284	10.23	1-2484	10.23
40	1-2217	7.88	1-2237	8.59	1-2266	9.75	1-2466	9.75	1-2285	10.47	1-2485	10.47
45	1-2218	8.17	1-2238	8.80	1-2267	9.95	1-2467	9.95	1-2286	10.70	1-2486	10.70
50	1-2219	8.38	1-2239	9.00	1-2268	10.64	1-2468	10.64	1-2287	11.76	1-2487	11.76
55			1-2240	9.05								
60	1-2221	9.00	1-2241	9.10	1-2270	11.00	1-2469	11.00	1-2289	12.43	1-2489	12.43
65			1-2242	9.37								
70	1-2223	9.15	1-2243	9.89	1-2272	11.79	1-2470	11.79	1-2291	13.11	1-2491	13.11
80	1-2225	9.35	1-2245	10.40	1-2274	12.36	1-2472	12.36	1-2293	14.25	1-2493	14.25
90	1-2227	9.50	1-2247	10.86	1-2276	13.00	1-2474	13.00	1-2295	15.16	1-2495	15.16
100	1-2229	9.90	1-2249	11.00	1-2278	13.39	1-2476	13.39	1-2297	16.75	1-2497	16.75
114	1-2214	10.26										
115			1-2252	15.63								
135	1-2230	18.65										

**GREAT FOR SUSPENSION, MOUNTING  
ENGINES & TRANSMISSIONS**

**MADE FROM 16-6 AGE HARDENING STAINLESS  
GREAT FOR EXHAUST - HAS THE SAME  
EXPANSION RATE AS MEDIUM CARBON STEEL**

**TUMBLE POLISHED TO A BRIGHT FINISH**



**TOLL FREE ORDER LINE : 1-800-767-4781**



# METRIC TWELVE POINT

HIGH STRENGTH - EQUIVALENT TO METRIC GRADE 10.9 - POLISHED  
MADE IN USA

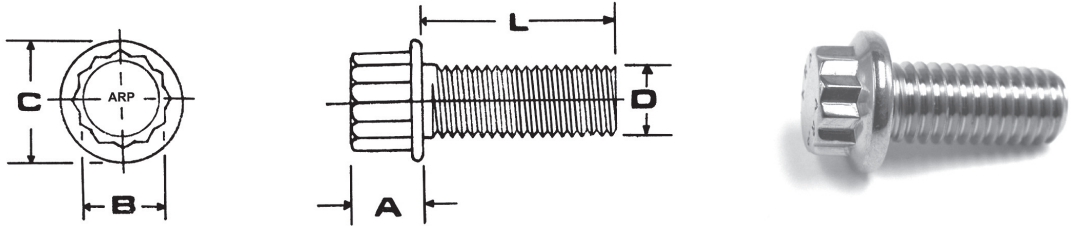

**DIMENSION TABLE (MILLIMETERS)**

<b>D</b>	<b>DIAMETER</b>	6	8	10	10	12	12
	<b>PITCH</b>	1.0	1.25	1.5	1.25	1.75	1.5
<b>A</b>	<b>HEAD HT.</b>	6.4	7.4	9.3	9.3	11.7	11.7
<b>B</b>	<b>WRENCH</b>	8	10	12	12	14	14
<b>C</b>	<b>FLANGE</b>	13	15	18	18	21.6	21.6

**PART NUMBER AND PRICE GUIDE**

<b>DIAMETER</b>	<b>6</b>		<b>8</b>		<b>10-1.5</b>		<b>10-1.25</b>		<b>12-1.75</b>		<b>12-1.5</b>	
<b>LENGTH</b>	<b>PART #</b>	<b>\$</b>	<b>PART #</b>	<b>\$</b>	<b>PART #</b>	<b>\$</b>	<b>PART #</b>	<b>\$</b>	<b>PART #</b>	<b>\$</b>	<b>PART #</b>	<b>\$</b>
12	1-2306	5.32										
16	1-2308	5.50	1-2331	5.64								
20	1-2310	5.67	1-2333	5.89	1-2363	6.46	1-2563	6.46				
25	1-2311	5.74	1-2334	5.92	1-2364	6.90	1-2564	6.90	1-2382	9.77	1-2582	9.77
30	1-2312	6.00	1-2335	6.52	1-2365	7.30	1-2565	7.30	1-2383	10.02	1-2583	10.02
35	1-2313	8.20	1-2336	9.07	1-2366	10.07	1-2566	10.07	1-2384	10.73	1-2584	10.73
40	1-2317	8.55	1-2337	9.43	1-2367	10.26	1-2567	10.26	1-2385	10.97	1-2585	10.97
45	1-2318	8.89	1-2338	9.68	1-2368	10.42	1-2568	10.42	1-2386	11.00	1-2586	11.00
50	1-2319	9.17	1-2339	10.12	1-2369	10.64	1-2569	10.64	1-2387	12.22	1-2587	12.22
55			1-2340	10.31								
60	1-2321	9.54	1-2341	10.56	1-2371	11.35	1-2571	11.35	1-2389	12.93	1-2589	12.93
65			1-2342	10.73								
70	1-2323	9.68	1-2343	10.89	1-2373	11.96	1-2573	11.96	1-2391	13.61	1-2591	13.61
80	1-2325	9.78	1-2345	11.00	1-2375	13.31	1-2575	13.31	1-2393	14.75	1-2593	14.75
90	1-2327	10.05	1-2347	11.56	1-2377	13.45	1-2577	13.45	1-2395	15.66	1-2595	15.66
100	1-2329	10.36	1-2349	12.30	1-2379	13.93	1-2579	13.93	1-2397	17.25	1-2597	17.25
114	1-2314	10.70										
115			1-2352	16.50								
135	1-2330	19.25										

## TWELVE POINT NUTS

- HIGH STRENGTH -



<b>SIZE</b>	<b>WRENCH</b>	<b>T</b>	<b>A</b>	<b>PART#</b>	<b>\$</b>
6-1.0	8	6.1	10.5	1-3091	10.30
8-1.25	10	8.2	13.5	1-3092	12.51
10-1.5	12	10.3	17.7	1-3093	12.71
10-1.25	12	10.3	17.7	1-3094	12.71
12-1.25	14	12	10	1-3097	12.97

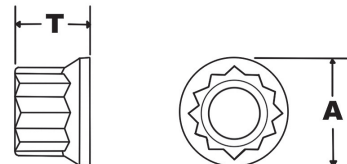

# METRIC BUTTON HEAD CAP SCREWS

A2-70 LOW STRENGTH DIN # 7380

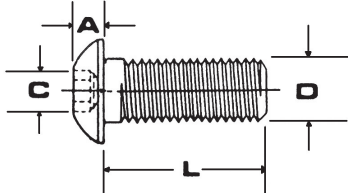
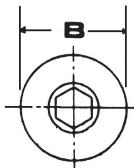

DIMENSION TABLE (MILLIMETERS)

D	DIAMETER	3	4	5	6	8	10	12
	PITCH	0.5	0.7	0.8	1.0	1.25	1.5	1.75
A	HEAD HT.	1.7	2.2	2.8	3.3	4.4	5.5	6.6
B	HEAD DIA.	5.7	7.6	9.5	10.5	14	17.5	21
C	KEY SIZE	2	2.5	3	4	5	6	8

## PART NUMBER AND PRICE GUIDE

DIAMETER		2	3	4	5	6	8	10	12							
LENGTH	PART#	\$	PART #	\$	PART #	\$	PART #	\$	PART #	\$	PART #	\$	PART #	\$	PART #	\$
4	1-1371	.29														
6			1-1300	.05	1-1357	.09										
8	1-1382	.59	1-1301	.06	1-1305	.11	1-1309	.12	1-1316	.29						
10			1-1302	.07	1-1306	.13	1-1310	.13	1-1317	.16	1-1323	.39				
12			1-1303	.08	1-1307	.14	1-1311	.17	1-1318	.17	1-1324	.41				
14					1-1354	.15	1-1355	.18	1-1356	.18	1-1358	.43				
16			1-1304	.09	1-1308	.16	1-1312	.19	1-1319	.19	1-1325	.45	1-1329	.89		
20			1-1359	.12	1-1350	.18	1-1313	.22	1-1320	.24	1-1326	.47	1-1330	.94	1-1368	1.29
25					1-1340	.21	1-1314	.25	1-1321	.26	1-1327	.49	1-1331	.99	1-1369	1.36
30					1-1362	.27	1-1315	.29	1-1322	.32	1-1328	.53	1-1332	1.19	1-1370	1.64
35							1-1367	.34	1-1338	.36	1-1336	.59	1-1335	1.28	1-1372	1.75
40					1-1341	.39	1-1363	.41	1-1339	.45	1-1337	.66	1-1334	1.65	1-1347	1.84
45							1-1333	.48	1-1342	.56	1-1366	.74				
50							1-1345	.59	1-1364	.64	1-1346	.83	1-1360	1.98		
55									1-1373	.69	1-1344	1.39				
60									1-1365	.72	1-1351	1.45	1-1361	2.24		
70									1-1343	.85	1-1349	1.69	1-1348	2.49		
80											1-1352	1.95				

BUTTON CAP SCREW SHOP ASSORTMENT: 620 PIECES # 3-3048 \$292.00  
 PERSONAL ASSORTMENT: 400 PIECES 3-3190 130.00



# METRIC FLAT SOCKET CAP SCREWS

LOW STRENGTH DIN #7991

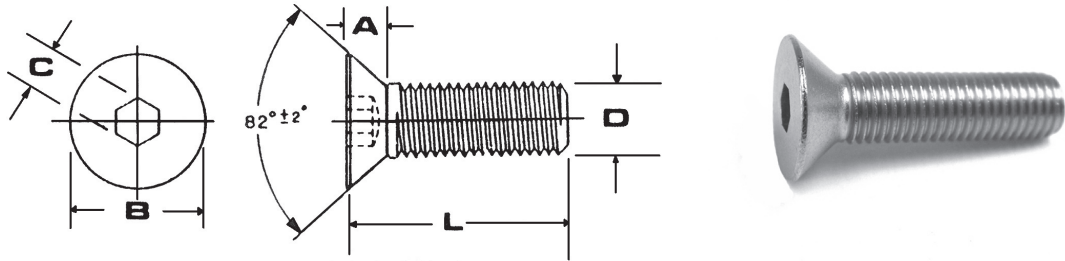

**DIMENSION TABLE (MILLIMETERS)**

D	DIAMETER	3	4	5	6	8	10	12
	PITCH	0.5	0.7	0.8	1.0	1.25	1.5	1.75
A	HEAD HT.	1.7	2.3	2.8	3.3	4.4	5.5	6.5
B	HEAD DIA.	6	8	10	12	16	20	24
C	KEY SIZE	2	2.5	3	4	5	6	8

## PART NUMBER AND PRICE GUIDE

DIAMETER	3		4		5		6		8		10		12	
LENGTH	PART #	\$	PART #	\$	PART #	\$	PART #	\$	PART #	\$	PART #	\$	PART #	\$
6	1-1400	.06												
8	1-1401	.06	1-1408	.10	1-1416	.11								
10	1-1402	.10	1-1409	.12	1-1417	.12	1-1425	.17						
12	1-1403	.11	1-1410	.15	1-1418	.16	1-1426	.19	1-1467	.36				
14			1-1463	.16	1-1462	.16	1-1461	.20	1-1465	.37				
16	1-1404	.12	1-1411	.18	1-1419	.17	1-1427	.23	1-1437	.38	1-1448	.79		
18							1-1464	.25						
20	1-1405	.13	1-1412	.18	1-1420	.18	1-1428	.26	1-1439	.45	1-1449	.82		
25	1-1406	.14	1-1413	.19	1-1421	.21	1-1429	.28	1-1440	.49	1-1450	.86	1-1457	1.35
30	1-1407	.16	1-1414	.22	1-1422	.23	1-1430	.38	1-1441	.57	1-1451	.98		
35			1-1415	.30	1-1423	.35	1-1431	.48	1-1442	.64	1-1452	1.13		
40					1-1424	.42	1-1432	.52	1-1443	.78	1-1453	1.25		
45							1-1433	.66	1-1444	.98				
50			1-1447	.69			1-1434	.75	1-1445	1.19	1-1455	1.38		
55									1-1468	1.25				
60							1-1460	.96	1-1446	1.29	1-1456	1.60		
70							1-1470	.97			1-1458	1.79		
80											1-1459	1.98		

**FLAT SOCKET PERSONAL ASSORTMENT: 400 PIECES # 3-3191 \$ 175.00**

**SHOP SIZE ASSORTMENT: 600 PIECES 3-3085 292.00**

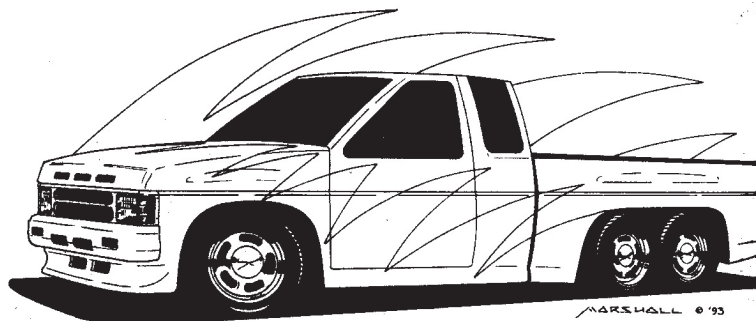

**TOLL FREE ORDER LINE : 1-800-767-4781**

# METRIC HEX HEAD CAP SCREWS

A2-70 LOW STRENGTH DIN #931 (PARTIALLY THREADED)/933 (FULLY THREADED)

DIMENSION TABLE (MILLIMETERS)

D	DIAMETER	3	4	5	6	8	10	12	14	16
	PITCH	0.5	0.7	0.8	1.0	1.25	1.5	1.75	2	2
A	HEAD HT.	2	2.8	3.5	4	5.5	7	8	9	10
B	HEAD DIA.	5.5	7	8	10	13	17	19	22	24

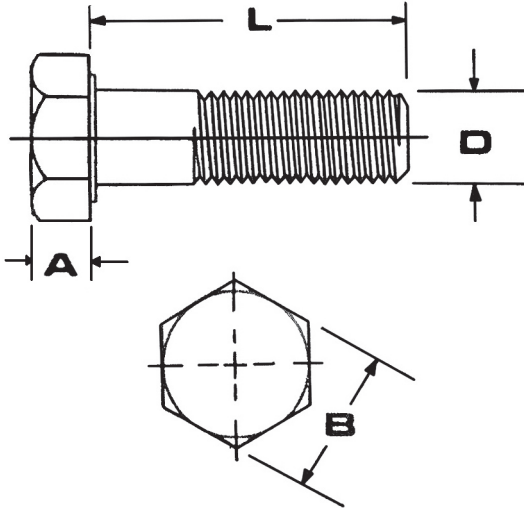

DIAMETER	3		4		5	
LENGTH	PART #	\$	PART #	\$	PART #	\$
6					1-1515	.16
8	1-1500	.17	1-1507	.17	1-1514	.17
10	1-1501	.17	1-1508	.17	1-1516	.17
12	1-1502	.19	1-1509	.18	1-1517	.19
16	1-1503	.21	1-1510	.19	1-1518	.21
20	1-1504	.23	1-1511	.21	1-1519	.23
25	1-1505	.27	1-1512	.20	1-1520	.26
30	1-1506	.28	1-1513	.25	1-1521	.29
35					1-1522	.37
40					1-1523	.39
45					1-1524	.41
50					1-1525	.59

DIAMETER	6		8		10		12		14		16	
LENGTH	PART#	\$	PART#	\$	PART#	\$	PART#	\$	PART#		PART#	
8	1-1592	.17										
10	1-1526	.18	1-1538	.34								
12	1-1527	.19	1-1539	.36								
14	1-1579	.20										
16	1-1528	.24	1-1540	.38	1-1553	.56						
18	1-1593	.39	1-1614	.38								
20	1-1529	.26	1-1541	.39	1-1554	.58	1-1566	.99				
25	1-1530	.28	1-1542	.43	1-1555	.60	1-1567	1.05				
30	1-1531	.29	1-1543	.56	1-1556	.64	1-1568	1.18				
35	1-1532	.33	1-1544	.60	1-1557	.67	1-1569	1.39			1-1586	2.95
40	1-1533	.36	1-1545	.65	1-1558	.72	1-1570	1.50				
45	1-1534	.39	1-1546	.72	1-1559	.84	1-1571	1.53				
50	1-1535	.44	1-1547	.78	1-1560	.95	1-1572	1.79	1-1583	3.00		
55	1-1536	.53	1-1548	.86	1-1561	1.21	1-1573	1.84				
60	1-1537	.59	1-1549	1.07	1-1562	1.24	1-1574	1.89				
65	1-1581	.80	1-1550	1.13	1-1563	1.49	1-1575	1.94				
70	1-1582	.83	1-1551	1.27	1-1564	1.56	1-1576	1.98				
75			1-1580	1.37	1-1601	1.60	1-1615	1.99				
80	1-1584	.95	1-1552	1.42	1-1565	1.72	1-1577	2.12				
90	1-1585	1.34	1-1578	1.73	1-1590	1.99	1-1595	2.69				
100	1-1597	1.38	1-1587	2.47	1-1591	2.48	1-1596	2.97				
110			1-1699	2.78	1-1599	2.99	1-1603	3.20				
120	1-1598	1.45			1-1602	2.99	1-1600	3.39	1-1604	5.90		
130					1-1605	3.19	1-1589	3.74				
150					1-1606	3.29	1-1594	4.50				
160							1-1608	5.60				
180	1-1588	4.90					1-1610	5.95				
200							1-1612	6.95				

ADDITIONAL SIZE:  
18-2.25 X 100  
1-1613 \$ 6.49  
\*LOW STRENGTH\*



# METRIC HEX HEAD CAP SCREWS

A4-80 MEDIUM STRENGTH - EQUIVALENT TO METRIC GRADE 8.8  
 DIN #931 (PARTIALLY THREADED)/933 (FULLY THREADED)

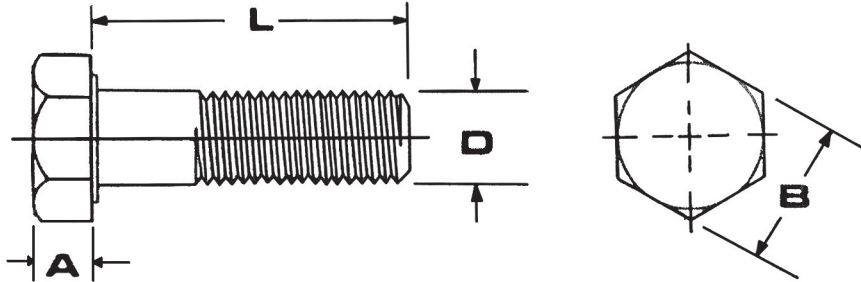

**DIMENSION TABLE (MILLIMETERS)**

D	DIAMETER	5	6	8	10	12
	PITCH	0.8	1.0	1.25	1.5	1.75
A	HEAD HT.	3.5	4	5.5	7	8
B	HEAD DIA.	8	10	13	17	19

**PART NUMBER AND PRICE GUIDE**

DIAMETER		5	6	8	10	12				
LENGTH	PART #	\$	PART #	\$	PART #	\$	PART #	\$	PART #	\$
10	1-1616	.55								
12	1-1617	.59	1-1627	.69						
16			1-1628	.74						
20			1-1629	.79	1-1641	1.35				
25			1-1630	.87	1-1642	1.47	1-1655	2.99	1-1667	4.48
30			1-1631	1.07	1-1643	1.59	1-1656	3.19	1-1668	4.67
35					1-1644	1.79	1-1657	3.28	1-1669	4.99
40			1-1633	1.34	1-1645	1.98	1-1658	3.40	1-1670	5.20
45					1-1646	2.26	1-1659	3.55	1-1671	5.47
50			1-1635	1.61	1-1647	2.58	1-1660	3.65	1-1672	5.74
60			1-1636	1.98	1-1650	2.99	1-1663	3.98	1-1674	5.98
70			1-1637	2.15	1-1651	3.49	1-1664	4.45	1-1675	6.84
80			1-1638	2.42	1-1652	3.98	1-1665	4.96	1-1676	6.94
90			1-1639	2.63	1-1653	4.49	1-1666	5.28	1-1677	7.47
100			1-1640	2.90	1-1654	4.80	1-1662	5.76	1-1678	7.98
110							1-1661	6.40		
120										
130										
140							1-1680	7.95		

**SHOP SIZE ASSORTMENT: 400 PIECES 3-3098 \$ 655.00**

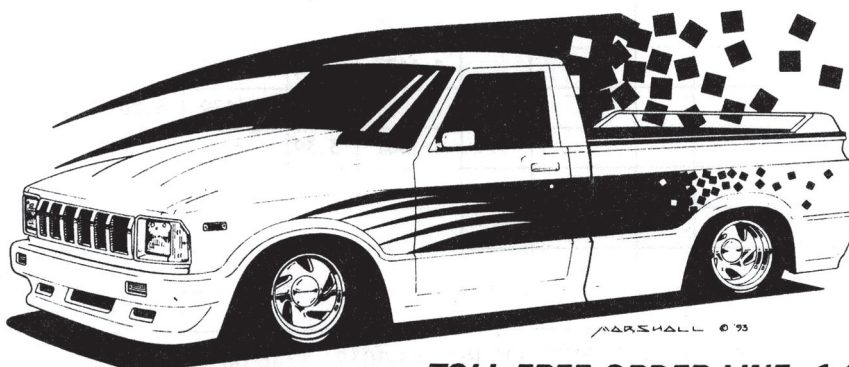

**TOLL FREE ORDER LINE: 1-800-767-4781**

# METRIC SOCKET HEAD CAP SCREWS

A2-70 LOW STRENGTH - DIN #912

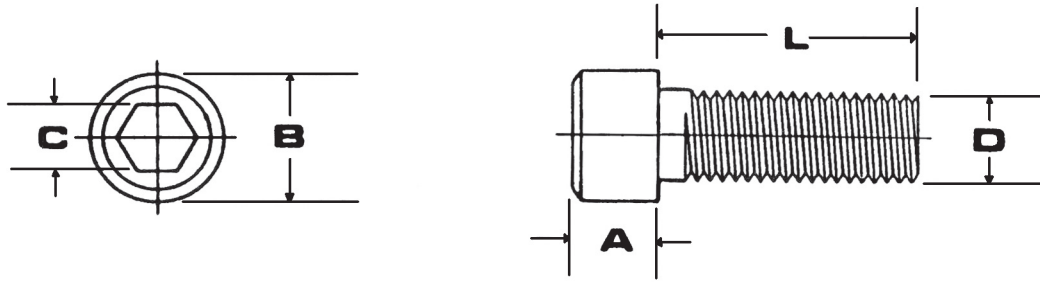

**DIMENSION TABLE (MILLIMETERS)**

ADDITIONAL  
SIZE:  
2.5-.45 X 5  
1-1009 \$.12

D	DIAMETER	3	4	5	6	8	10	12
	PITCH	0.5	0.7	0.8	1.0	1.25	1.5	1.75
A	HEAD HT.	3	4	5	6	8	10	12
B	HEAD DIA.	5.4	6.9	8.3	10	13	16	18
C	KEY SIZE	2.5	3	4	5	6	8	10

SOCKET CAP SCREW SHOP  
ASSORTMENT: 620 PIECES  
#3-3012 \$305.00  
PERSONAL ASSORTMENT:  
400 PIECES #3-3193 \$155.00

**PART NUMBER AND PRICE GUIDE**

DIAMETER	3	4	5	6	8	10	12							
LENGTH	PART#	\$	PART#	\$	PART#	\$	PART#	\$	PART#	\$	PART#	\$	PART#	\$
4	1-1006	.13												
6	1-1100	.14	1-1112	.17	1-1126	.27	1-1140	.35						
8	1-1101	.15	1-1113	.18	1-1127	.22	1-1141	.32						
10	1-1102	.15	1-1114	.19	1-1128	.23	1-1142	.27	1-1156	.60				
12	1-1103	.16	1-1115	.20	1-1129	.24	1-1143	.25	1-1157	.62				
14	1-1104	.18	1-1116	.22	1-1130	.27	1-1144	.27	1-1158	.64				
16	1-1105	.19	1-1117	.23	1-1131	.28	1-1145	.28	1-1159	.66	1-1170	.96		
18	1-1106	.20	1-1118	.26	1-1132	.30	1-1146	.33	1-1160	.68				
20	1-1107	.21	1-1119	.28	1-1133	.32	1-1147	.34	1-1161	.70	1-1172	.94	1-1189	1.69
22			1-1098	.31										
25	1-1108	.26	1-1120	.33	1-1134	.33	1-1148	.35	1-1162	.72	1-1173	.89	1-1190	1.32
30	1-1109	.33	1-1121	.38	1-1135	.35	1-1149	.39	1-1163	.74	1-1174	.99	1-1191	1.59
35	1-1110	.38	1-1122	.44	1-1136	.40	1-1150	.42	1-1164	.76	1-1175	1.05	1-1192	1.65
40	1-1111	.44	1-1123	.55	1-1137	.41	1-1151	.45	1-1165	.78	1-1180	1.09	1-1193	1.67
45			1-1124	.57	1-1138	.43	1-1152	.49	1-1166	.79	1-1181	1.59	1-1194	1.69
50			1-1125	.59	1-1139	.47	1-1153	.55	1-1167	.89	1-1182	1.30	1-1195	1.72
55					1-1030	.90	1-1015	.58	1-1168	.91	1-1183	1.40	1-1196	2.37
60					1-1031	.90	1-1016	.69	1-1169	.96	1-1184	1.71	1-1197	2.38
65					1-1004	.99	1-1021	.78	1-1036	.99	1-1003	1.85		
70					1-1032	1.06	1-1017	.90	1-1176	1.19	1-1185	1.98	1-1198	2.77
75														
80			1-1008	.88	1-1033	1.29	1-1018	.95	1-1171	1.48	1-1186	2.10	1-1199	2.96
90					1-1034	2.50	1-1019	.99	1-1201	1.90	1-1187	2.49	1-1154	3.27
100					1-1035	4.50	1-1020	1.84	1-1178	2.85	1-1188	2.98	1-1155	3.49
110							1-1177	1.97	1-1099	3.75	1-1005	3.45	1-1000	6.38
120							1-1061	2.48	1-1179	3.80	1-1202	3.95	1-1001	6.96
130							1-1062	3.39			1-1209	4.60	1-1002	7.50
140									1-1014	4.20	1-1203	5.50		
150											1-1206	6.90		
160											1-1207	10.90		
170														
180											1-1208	14.90		

# METRIC SOCKET HEAD CAP SCREWS

A4-80 MEDIUM STRENGTH - EQUIVALENT TO METRIC GRADE 8.8 DIN #912

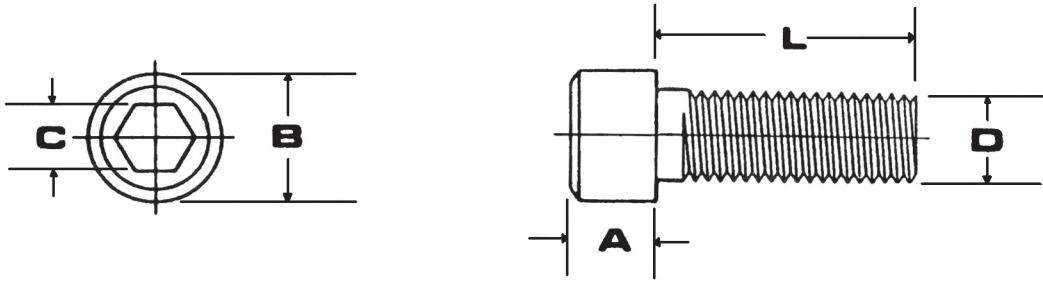

**DIMENSION TABLE (MILLIMETERS)**

D	DIAMETER	5	6	8	10	12
	PITCH	0.8	1.0	1.25	1.5	1.75
A	HEAD HT.	5	6	8	10	12
B	HEAD DIA.	8.3	10	13	16	18
C	KEY SIZE	4	5	6	8	10

**PART NUMBER AND PRICE GUIDE**

DIAMETER		5		6		8		10		12	
LENGTH	PART #	\$	PART #	\$	PART #	\$	PART #	\$	PART #	\$	
10			1-1243	.54							
12											
16			1-1245	.65	1-1259	1.19					
20	1-1233	.65	1-1247	.68	1-1261	1.37	1-1272	2.96			
25			1-1248	.70	1-1262	1.46	1-1273	3.24	1-1290	4.80	
30	1-1236	.77	1-1249	.79	1-1263	1.58	1-1274	3.67	1-1291	4.92	
35			1-1250	.87	1-1264	1.75	1-1275	3.94	1-1292	5.16	
40	1-1238	.98	1-1251	.96	1-1265	1.86	1-1280	3.99	1-1293	5.40	
45			1-1252	1.18			1-1281	4.15			
50	1-1240	1.17	1-1253	1.32	1-1267	2.32	1-1282	4.27	1-1295	5.98	
55					1-1268	2.44	1-1283	4.39			
60			1-1255	1.45	1-1269	2.55	1-1284	4.50	1-1297	6.44	
70			1-1256	1.52	1-1276	2.85	1-1285	4.80	1-1298	6.76	
80			1-1257	2.09	1-1271	3.20	1-1289	4.99	1-1299	7.60	
90	1-1234	4.50					1-1287	5.60	1-1200	7.95	
100	1-1235	4.75					1-1288	5.80	1-1220	8.80	
110							1-1286	6.90			

**SHOP SIZE ASSORTMENT: 400 PIECES 3-3099 \$ 670.00**

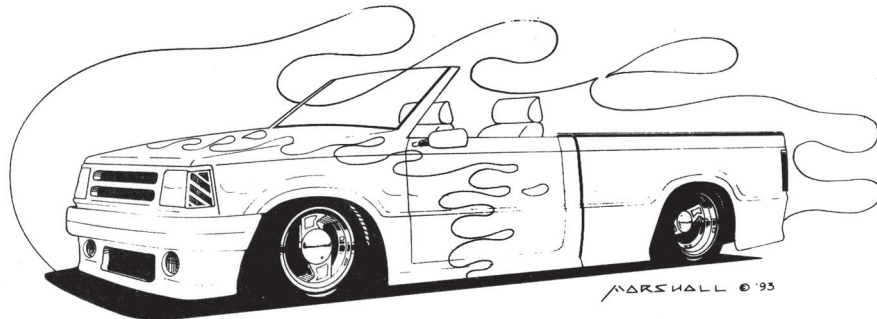

**TOLL FREE ORDER LINE : 1-800-767-4781**

# METRIC STUDS



LOW STRENGTH A2-70

\* HIGH STRENGTH - EQUIVALENT TO METRIC GRADE 10.9 \*

**NOTE:** WHEN MEASURING METRIC STUDS, THE LENGTH IS FROM THE MOUNTING SURFACE OUT  
 - FOR EXAMPLE ON AN EXHAUST STUD DON'T INCLUDE THE THREADED PART THAT IS IN THE BLOCK.

**\*\*BALL END IS ON ARP STUDS ONLY\*\***

SIZE	6 MM		6 MM ARP*		8 MM		8 MM ARP*		10 MM	
LENGTH	PART#	\$	PART#	\$	PART#	\$	PART#	\$	PART#	\$
20	1-1763	1.95	1-1770	9.25	1-1748	1.99				
25	1-1764	1.99			1-1754	2.21	1-1782	9.50		
30	1-1765	1.39			1-1755	2.39	1-1783	9.75		
35	1-1766	2.30			1-1753	2.49	1-1784	10.00		
40	1-1767	2.50			1-1750	2.65	1-1785	10.25	1-1775	3.99
45	1-1768	2.65								
50					1-1751	2.78			1-1759	4.60
55					1-1746	3.19	1-1788	14.50		
60					1-1747	3.83				
70					1-1756	4.26				
80					1-1758	4.74				

**NOTE:** WE CUSTOM MAKE BOTH LOW AND HIGH STRENGTH STUDS, BALL ENDS ARE AVAILABLE AS AN OPTION

# METRIC HEX SOCKET SET SCREWS

DIN #916

SIZE	3 MM		4 MM		5 MM		6 MM		8 MM		10 MM	
LENGTH	PART#	\$	PART #	\$	PART #	\$	PART #	\$	PART #	\$	PART #	\$
4	1-1710	.07										
6			1-1702	.09	1-1720	.11	1-1731	.16				
8			1-1703	.10	1-1721	.13	1-1732	.19	1-1714	.24		
10			1-1704	.12	1-1722	.15	1-1733	.19	1-1715	.29	1-1718	.39
12			1-1705	.14	1-1723	.17	1-1734	.19	1-1716	.35	1-1719	.53
16	1-1712	.15	1-1706	.17	1-1724	.21	1-1738	.28	1-1743	.47	1-1760	.66
20			1-1707	.21	1-1725	.29	1-1739	.35	1-1744	.49	1-1761	.78
25			1-1708	.25	1-1726	.34	1-1735	.35	1-1745	.54	1-1701	.87
30					1-1727	.49	1-1736	.38	1-1730	.59	1-1713	.99
35					1-1728	.93	1-1737	.40				
40					1-1729	.99	1-1740	.50	1-1749	1.09	1-1717	1.59
45							1-1741	.72				
50							1-1742	.75	1-1752	1.82	1-1762	1.98

\* 8 X 12 HIGH STRENGTH SET SCREWS - 17-4 PH # 1-1700 \$ 1.98

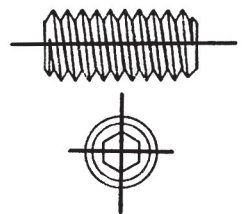

\*LONGER SIZES OF SET SCREWS MAKE GREAT CARBURETOR STUDS!

# THREADED ROD

- ALL ROD IS SOLD IN (1)METER LENGTHS -

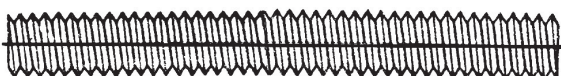

SIZE	PART#	\$
5 MM	1-4905	8.50
6 MM	1-4906	9.90
8 MM	1-4907	12.80
10 MM	1-4908	18.70



# METRIC CARRIAGE BOLTS

A2-70 LOW STRENGTH DIN #603

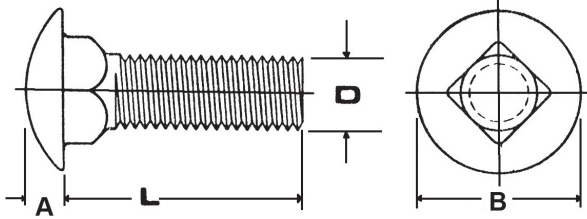

DIMENSION TABLE (MILLIMETERS)

D	DIAMETER	6	8	10	12
	PITCH	1.0	1.25	1.5	1.75
A	HEAD HT.	3.1	4.1	4.6	6.0
B	HEAD DIA.	15	19	23	29

PART NUMBER AND PRICE GUIDE

SIZE	6 MM		8 MM		10 MM		12 MM	
LENGTH	PART #	\$	PART #	\$	PART #	\$	PART #	\$
20	1-1812	.29	1-1809	.49				
25	1-1813	.34	1-1821	.57	1-1853	.79		
30	1-1814	.38	1-1822	.64	1-1854	.89	1-1885	1.59
35	1-1815	.44	1-1823	.69	1-1855	.99	1-1886	1.78
40	1-1816	.49	1-1824	.78	1-1856	1.14	1-1887	1.99
50	1-1817	.55	1-1826	.89	1-1858	1.27	1-1889	3.60
60	1-1818	.66	1-1828	1.09	1-1859	1.39		
70	1-1819	.78	1-1830	1.29				
80	1-1820	.89	1-1832	1.39				
100							1-1896	7.25
120							1-1898	7.80

# METRIC CHEESE HEAD MACHINE SCREWS

A2-70 LOW STRENGTH - DIN #84

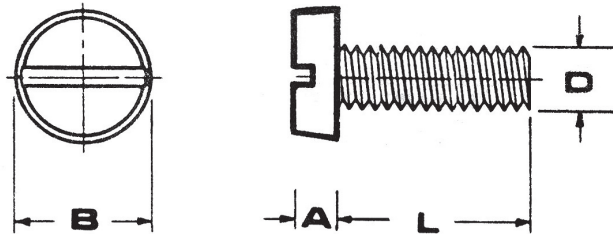

DIMENSION TABLE (MILLIMETERS)

D	DIAMETER	4	5	6	8
	PITCH	0.7	0.8	1.0	1.25
A	HEAD HT.	2.6	3.3	3.9	5
B	HEAD DIA.	7	8.5	10	13

PART NUMBER AND PRICE GUIDE

SIZE	4 MM		5 MM		6 MM		8 MM	
LENGTH	PART #	\$	PART #	\$	PART #	\$	PART #	\$
10	1-4017	.08	1-4027	.12	1-4038	.19		
12	1-4018	.09	1-4028	.15	1-4039	.21		
16	1-4019	.10	1-4029	.19	1-4040	.25		
20	1-4020	.12	1-4030	.22	1-4041	.29	1-4051	.39
25	1-4021	.15	1-4031	.25	1-4042	.35	1-4052	.48
30	1-4022	.18	1-4032	.27	1-4043	.44	1-4053	.55
40	1-4024	.22	1-4035	.33	1-4045	.51	1-4054	.69
45					1-4046	.62		
50					1-4047	.66		

# METRIC FLAT HEAD MACHINE SCREWS

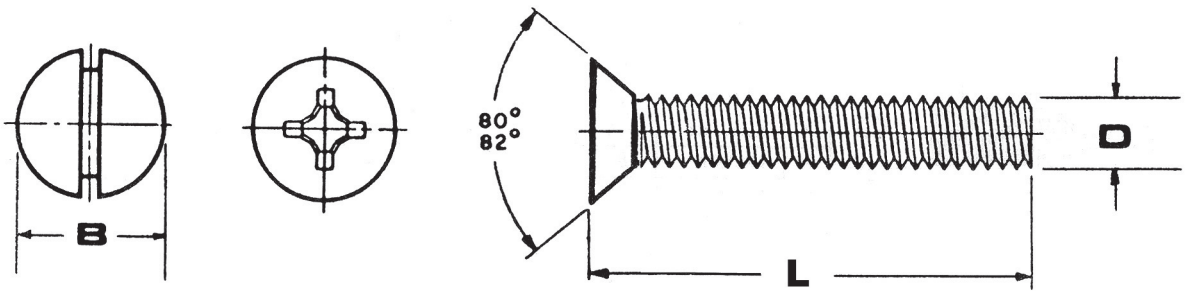

**DIMENSION TABLE (MILLIMETERS)**

D	DIAMETER	3	4	5	6	8
	PITCH	0.5	0.7	0.8	1.0	1.25
B	HEAD DIA.	5.6	7.5	9.2	11	14.5

**SLOTTED HEAD PART NUMBER AND PRICE GUIDE: DIN #963**



SIZE	3		4		5		6		8	
LENGTH	PART#	\$	PART#	\$	PART#	\$	PART#	\$	PART#	\$
6	1-4150	.05	1-4162	.09						
8	1-4151	.06	1-4163	.10	1-4175	.13				
10	1-4152	.07	1-4164	.12	1-4176	.14	1-4187	.22		
12	1-4153	.08	1-4165	.13	1-4177	.15	1-4188	.23	1-4197	.45
16	1-4154	.09	1-4166	.14	1-4178	.17	1-4189	.25	1-4198	.49
18					1-4186	.19				
20	1-4155	.10	1-4167	.15	1-4179	.19	1-4190	.27	1-4199	.55
25					1-4180	.22	1-4191	.30		
30					1-4181	.25	1-4192	.35	1-4201	.66
35			1-4170	.26						
40							1-4194	.41		
45			1-4172	.39						
50							1-4196	.46	1-4205	.98
70							1-4160	.49		

**PHILLIPS HEAD PART NUMBER AND PRICE GUIDE: DIN #965**



SIZE	3		4		5		6		8	
LENGTH	PART#	\$	PART#	\$	PART#	\$	PART#	\$	PART#	\$
6	1-4210	.07	1-4219	.11						
8	1-4211	.07	1-4220	.12	1-4229	.18	1-4239	.24		
10	1-4212	.08	1-4221	.13	1-4230	.19	1-4240	.27	1-4249	.50
12	1-4213	.09	1-4222	.14	1-4231	.20	1-4241	.29	1-4217	.56
16	1-4214	.10	1-4223	.15	1-4232	.21	1-4242	.33	1-4218	.62
20	1-4215	.11	1-4224	.16	1-4233	.23	1-4243	.36	1-4248	.69
25			1-4207	.18	1-4234	.27	1-4244	.39	1-4208	.78
30			1-4226	.19	1-4235	.29	1-4245	.43	1-4227	.82
35					1-4236	.39	1-4246	.49	1-4238	.85
40					1-4237	.48	1-4247	.59	1-4228	.89
45									1-4209	.91

PHILLIPS FLAT MACHINE SCREW SHOP ASSORTMENT: 1720 PIECES # 3-3082 \$311.50



# METRIC OVAL HEAD MACHINE SCREWS

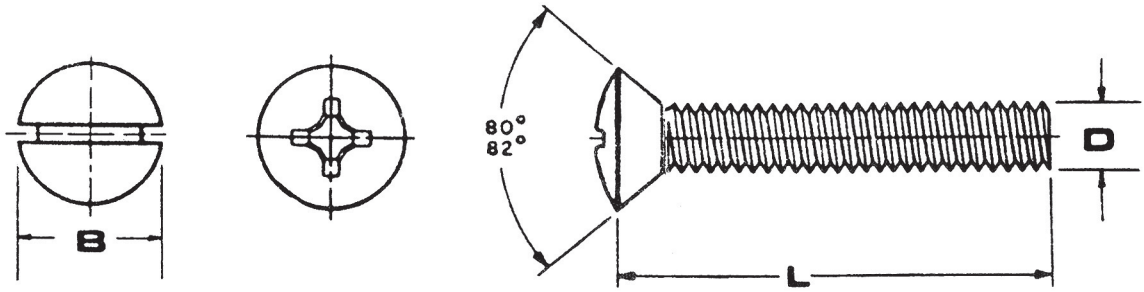

**DIMENSION TABLE (MILLIMETERS)**

D	DIAMETER	3	4	5	6	8
	PITCH	0.5	0.7	0.8	1.0	1.25
B	HEAD DIA.	5.6	7.5	9.2	11	14.5

**SLOTTED HEAD PART NUMBER AND PRICE GUIDE: DIN #964**

SIZE	3		4		5		6		8	
LENGTH	PART#	\$	PART#	\$	PART#	\$	PART#	\$	PART#	\$
6	1-4250	.07	1-4262	.12						
8	1-4251	.08	1-4263	.13	1-4275	.27				
10	1-4252	.09	1-4264	.14	1-4276	.27	1-4287	.31		
12	1-4253	.10			1-4277	.28	1-4288	.32		
16	1-4254	.11			1-4278	.29	1-4289	.33	1-4298	.49
20	1-4255	.12	1-4267	.17	1-4279	.30	1-4290	.36	1-4299	.53
25	1-4256	.14	1-4268	.19	1-4280	.33			1-4300	.61
30	1-4257	.19	1-4269	.23	1-4281	.37	1-4292	.44	1-4301	.69
35										
40			1-4271	.39			1-4294	.63		
45							1-4295	.69		
50			1-4273	.55	1-4285	.59	1-4296	.75		
60			1-4274	.58						



**PHILLIPS HEAD PART NUMBER AND PRICE GUIDE: DIN #966**

SIZE	3		4		5		6		8	
LENGTH	PART#	\$	PART#	\$	PART#	\$	PART#	\$	PART#	\$
6	1-4310	.07	1-4319	.11						
8	1-4311	.08	1-4320	.12	1-4329	.18	1-4339	.28		
10	1-4312	.09	1-4321	.13	1-4330	.19	1-4340	.19		
12	1-4313	.10	1-4322	.14	1-4331	.14	1-4341	.15	1-4349	1.25
16	1-4314	.11	1-4323	.15	1-4332	.18	1-4342	.25		
20	1-4315	.12	1-4324	.16	1-4333	.20	1-4343	.26	1-4351	.53
25	1-4316	.14	1-4325	.19	1-4334	.27	1-4344	.39	1-4352	.74
30			1-4326	.23	1-4335	.31	1-4345	.43	1-4353	.76
35					1-4336	.39	1-4346	.49	1-4354	.98
40			1-4327	.29	1-4337	.49	1-4347	.59	1-4355	1.26
45									1-4356	1.35
50					1-4359	.56	1-4348	.62	1-4360	1.39
60					1-4338	.60	1-4357	.65	1-4358	1.48



**PHILLIPS OVAL ASSORTMENT - SHOP -24 SIZES 3 X 8 THRU 8 X 30 - 1720 PIECES 3-3072 \$311.25  
 PERSONAL - 18 SIZES - 850 PIECES 3-3197 \$177.00**

**TOLL FREE ORDER LINE : 1-800-767-4781**

# METRIC PAN HEAD MACHINE SCREWS

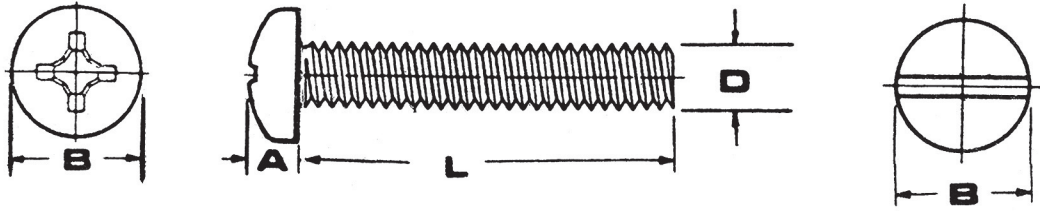

DIMENSION TABLE (MILLIMETERS)

D	DIAMETER	2	3	4	5	6	8
	PITCH	.04	0.5	0.7	0.8	1.0	1.25
A	HEAD HT. SLOTTED	1.2	1.8	2.4	3	3.6	5
A	HEAD HT. PHILLIPS	1.6	2.4	3.1	3.8	4.6	6
B	HEAD DIA.	4	6	8	10	12	16



SLOTTED HEAD PART NUMBER AND PRICE GUIDE: DIN #0085

SIZE	2	3	4	5	6	8						
LENGTH	PART#	\$	PART#	\$	PART#	\$	PART#	\$	PART#	\$	PART#	\$
6	1-4106	.04	1-4100	.07	1-4112	.11						
8			1-4101	.08	1-4113	.12	1-4125	.18				
10			1-4102	.09	1-4114	.13	1-4126	.19	1-4137	.25		
12			1-4103	.09	1-4115	.14	1-4127	.21	1-4138	.28	1-4147	.84
16			1-4104	.10	1-4116	.15	1-4128	.23	1-4139	.31		
20			1-4105	.11	1-4117	.17	1-4129	.26	1-4140	.34	1-4148	.96
25					1-4118	.19	1-4130	.29	1-4141	.38		
30					1-4119	.21	1-4131	.33	1-4142	.41		
35					1-4120	.23			1-4143	.45		
40									1-4144	.49	1-4145	1.12



PHILLIPS HEAD PART NUMBER AND PRICE GUIDE: DIN #7985

SIZE	3	4	5	6	8					
LENGTH	PART#	\$	PART#	\$	PART#	\$	PART#	\$	PART#	\$
6	1-4060	.07	1-4070	.10	1-4056	.19				
8	1-4061	.07	1-4071	.11	1-4081	.21	1-4078	.36		
10	1-4062	.08	1-4072	.12	1-4082	.19	1-4091	.26	1-4069	.99
12	1-4063	.08	1-4073	.13	1-4083	.21	1-4092	.27	1-4079	.76
16	1-4064	.09	1-4074	.14	1-4084	.23	1-4093	.29	1-4080	.80
20	1-4065	.10	1-4075	.16	1-4085	.26	1-4094	.33	1-4099	.85
25	1-4066	.12	1-4076	.18	1-4086	.29	1-4095	.36	1-4058	.89
30	1-4067	.16	1-4077	.20	1-4087	.32	1-4096	.40	1-4110	.97
35	1-4059	.18	1-4057	.22	1-4088	.35	1-4097	.44	1-4111	1.15
40			1-4055	.23	1-4089	.39	1-4098	.49	1-4122	1.18
45					1-4090	.87	1-4134	.53		
50			1-4049	.24						
60							1-4124	.85	1-4109	1.25
70							1-4068	.92		

PHILLIPS PAN ASSORTMENT - SHOP - 24 SIZES 3 X 8 THRU 8 X 30 - 1720 PIECES - 3-3068 \$311.50  
 PERSONAL - 18 SIZES 850 PIECES - 3-3199 \$ 205.00





# METRIC NUTS

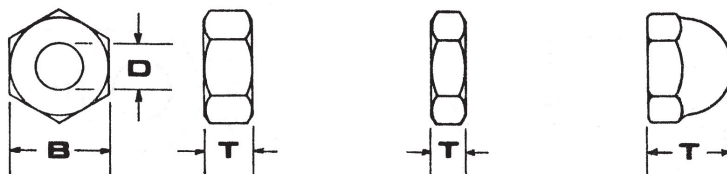

SEE PAGE 73 FOR TWELVE POINT NUTS

SIZE	PITCH	WRENCH	FULL HEX: DIN #934			JAM NUT: DIN #439			ACORN NUT: DIN #1587		
D		B	T	PART#	\$	T	PART#	\$	T	PART#	\$
3	0.5	5.5	2.4	1-3007	.03	1.8	1-3014	.11	6	1-3000	.65
4	0.7	7	3.2	1-3008	.04	2.2	1-3015	.07	8	1-3001	.45
5	0.8	8	4	1-3009	.05	2.7	1-3016	.06	10	1-3002	.45
6	1.0	10	5	1-3010	.09	3.2	1-3017	.09	12	1-3003	.45
7	1.0	11	5.2	1-3052	.29						
8	1.25	13	6.5	1-3011	.17	4	1-3018	.17	15	1-3004	.59
10	1.5	17	8	1-3012	.29	5	1-3019	.30	18	1-3005	1.10
12	1.75	19	10	1-3013	.49	6	1-3020	.49	22	1-3006	1.69
12	1.75	19	10	1-3061*	1.98	* A4-80 MEDIUM STRENGTH NUT					
14	2.0	22	10.3	1-3036	.84						
16	2.0	24	12.3	1-3053	.99						
20	2.5	30	14.9	1-3037	1.69						
- FINE THREAD -											
8	1.0	13	6.5	1-3048	.48						
10	1.25	17	8	1-3049	.59						
10	1.25	17	8	1-3060*	1.49	* A4-80 MEDIUM STRENGTH NUT					
12	1.50	19	10	1-3050	.64						
14	1.50	22	10.3	1-3051	.98		1-3068	.98			

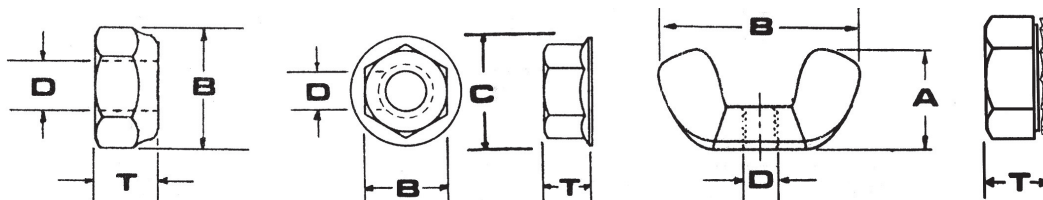

SIZE	NYLON INSERT LOCK NUTS: DIN #985						SERRATED FLANGE NUTS: DIN #6923				WING NUTS: DIN #315				'KEP' NUTS DIN #934K			
D	PITCH	B	T	PART#	\$		C	T	PART#	\$	B	A	PART#	\$	B	T	PART#	\$
3	0.5	5.5	4	1-3021	.06						19	9.5	1-3030	.91				
4	0.7	7	5	1-3022	.08						19	9.5	1-3031	1.20				
5	0.8	8	5	1-3023	.11	11.5	4.8	1-3058	.15		22	11	1-3032	1.40	8	4	1-3062	.27
6	1.0	10	6	1-3024	.14	13.4	5.8	1-3054	.19		28	14	1-3033	1.55	10	5	1-3063	.34
8	1.25	13	10	1-3025	.19	17.1	8	1-3055	.28		30	15	1-3034	1.95	13	6.5	1-3064	.58
10	1.5	17	10	1-3026	.39	21	10	1-3056	.48		36	18	1-3035	2.35	17	8	1-3066	.99
12	1.75	19	12	1-3027	.68	25	11.7	1-3057	.86		46	24	1-3038	6.04				
14	2.0	22	14	1-3039	1.07													
16	2.0	24	16	1-3029	1.31													
18	2.25	26	18	1-3028	2.49													
20	2.5	30	20	1-3040	2.98													
- FINE THREAD -																		
12	1.5	19	12	1-3045	2.88													
14	1.5	22	14	1-3046	4.70													

NUT/LOCK/WASHER SHOP ASSORTMENT: 2000 PIECES # 3-3013 \$ 185.00  
 PERSONAL ASSORTMENT: 1200 PIECES # 3-3194 \$ 95.00

# METRIC SLOTTED HEX NUTS

SIZE	B WRENCH	C COTTER KEY SIZE	PART#	\$
10-1.0	5/8 (16MM)	1/8 X 1-1/4 2-5015	1-3083	15.75
10-1.25			1-3082	
10-1.5			1-3081	
12-1.25	3/4 (19MM)	5/32 x 1-1/4 2-5022	1-3084	18.50
12-1.5			1-3085	
12-1.75			1-3077	
14-1.5	7/8 (22.3MM)	5/32 X 1-1/2 2-5023	1-3086	20.50
14-1.75			1-3087	
14-2.0			1-3079	
16-1.5	1" (25.4 MM)	3/16 X 1-1/2 2-5029	1-3088	23.50
16-1.75			1-3089	
16-2.0			1-3075	

**HIGH STRENGTH SLOTTED TALL NUTS**  
 - MADE IN USA - COMMONLY CALLED "CASTLE NUTS" - USE THESE ON SUSPENSION PARTS (BALL JOINTS, TIE ROD ENDS, IDLER ARMS, ETC.)

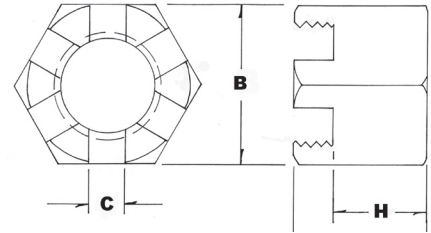

\* WE MACHINE THE HEIGHT TO MATCH YOUR NEEDS - SPECIFY (H) DISTANCE FROM BOTTOM OF NUT TO BOTTOM OF SLOTS.

# METRIC LOCK WASHERS

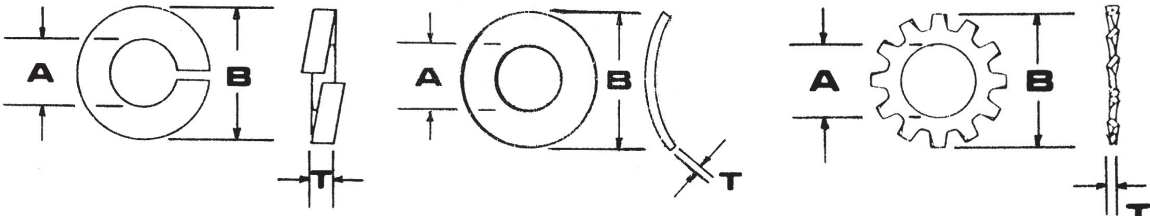

BOLT SIZE	SPLIT LOCK					CURVED SPRING WASHER					EXTERNAL STAR				
	A	B	T	PART #	\$	A	B	T	PART #	\$	A	B	T	PART #	\$
3	3.1	6.2	0.8	1-2100	.03	3.2	6	0.4	1-2107	.03	3.2	6.0	0.4	1-2113	.05
4	4.1	7.6	0.9	1-2101	.03						4.3	8.0	0.5	1-2114	.05
5	5.1	9.2	1.2	1-2102	.04						5.3	10.0	0.6	1-2115	.06
6	6.1	11.8	1.6	1-2103	.06	6.4	11	0.5	1-2110	.07	6.4	11.0	0.7	1-2116	.07
8	8.1	14.8	2.0	1-2104	.08	8.4	15	0.5	1-2111	.12	8.4	15.0	0.8	1-2117	.09
10	10.2	18.1	2.2	1-2105	.14						10.5	18.0	0.9	1-2118	.16
12	12.2	21.1	2.5	1-2106	.19						12.5	20.5	1.0	1-2119	.19
14	14.2	24.1	3	1-2129	.49	15.0	28	1.6	1-2128	.69					



## VIBRATION PROOF LOCK WASHERS - 316 SS -

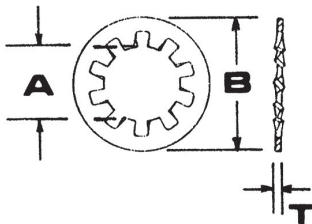

BOLT SIZE	INTERNAL STAR				
	A	B	T	PART #	\$
3	3.2	6	0.4	1-2120	.05
4	4.3	8	0.5	1-2121	.06
5	5.3	10	0.6	1-2122	.06
6	6.4	11	0.7	1-2123	.07
8	8.4	15	0.8	1-2124	.09
10	10.5	18	0.9	1-2125	.15
12	12.5	20.5	1.0	1-2126	.19

SIZE	O.D.	PART#	\$
5MM	8.9MM (.35")	2-4371	1.52
6MM	11.4MM (.45")	2-4374	1.85
6MM	13.5MM (.53")	2-4394	1.95
8MM	13.5MM (.53")	2-4375	2.31
8MM	16.5MM (.65")	2-4395	2.73
10MM	16MM (.62")	2-4377	2.99
10MM	20.8MM (.83")	2-4396	5.20
12MM	19.5MM (.77")	2-4379	3.94
14MM	23.1MM (.91")	2-4380	5.51
16MM	25.44MM (1")	2-4381	5.51

**NOTE:** (2) PAIRS ARE NEEDED WHEN THE BOLT IS USED WITH A NUT - (1) FOR UNDER THE BOLT & (1) FOR UNDER THE NUT - WILL NOT WORK WITH FLAT WASHERS!

# METRIC WASHERS

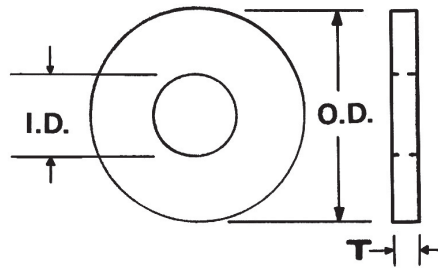

SIZE	NAME	I.D.	O.D.	T	PART#	\$
3 MM	MS803	3.2	6.4	0.5	2-4260	.03
	MS804	3.2	7.9	0.6	2-4224	.03
	#4 STAND	3.2	8.0	0.5	2-4212	.03
	#4 AN	3.2	8.0	0.6	2-4200	.03
	3MM SMALL	3.3	5.7	0.4	1-2000	.03
	3MM STAND	3.3	7.0	0.5	1-2008	.03
	3MM LARGE	3.3	8.8	0.7	1-2016	.03
4 MM	MS806	4.3	9.5	1.0	2-4225	.03
	#8 STAND	4.4	9.5	0.6	2-4214	.03
	4MM SMALL	4.4	8.0	0.5	1-2001	.05
	4MM STAND	4.4	8.9	0.8	1-2009	.03
	4MM LARGE	4.4	11.8	0.9	1-2017	.05
	#8 FENDER	4.4	19.0	1.1	2-4286	.08
5 MM	#8 AN	4.5	9.5	0.8	2-4202	.03
	#10 FENDER	5.2	17.4	1.1	2-4236	.08
	#10 FENDER	5.2	25.4	1.1	2-4237	.13
	#10 AN	5.3	11.1	1.5	2-4203	.03
	5MM SMALL	5.4	8.8	0.9	1-2002	.05
	5MM STAND	5.4	9.9	0.9	1-2010	.03
	5MM LARGE	5.4	15.0	0.9	1-2018	.07
6 MM	MS808	5.5	11.1	0.9	2-4262	.03
	#12 STAND	6.2	12.6	1.0	2-4216	.05
	6MM SMALL	6.5	11.0	1.4	1-2003	.05
	6MM STAND	6.5	12.1	1.4	1-2011	.04
	MS809	6.5	14.2	1.4	2-4227	.06
	6MM LARGE	6.5	17.8	1.4	1-2019	.12
	1/4 HEAVY	6.5	19.0	1.8	2-4277	.27
	1/4 AN	6.7	12.7	1.5	2-4205	.04

SIZE	NAME	I.D.	O.D.	T	PART#	\$	
8 MM	CLEVIS	8.0	16.0	2.0	1-2033	.18	
	MS811	8.1	18.5	1.4	2-4229	.09	
	5/16 HEAVY	8.3	21.6	2.2	2-4248	.38	
	5/16 AN	8.4	14.4	1.4	2-4206	.05	
	8MM SMALL	8.5	14.7	1.4	1-2004	.06	
	8MM STAND	8.5	15.7	1.4	1-2012	.06	
	5/16 STAND	8.6	19.0	1.3	2-4218	.06	
	8MM LARGE	8.6	23.7	1.8	1-2020	.25	
	MS812	8.8	17.4	1.4	2-4264	.06	
	5/16 FENDER	8.8	31.8	1.3	2-4287	.24	
10 MM	5/16 FENDER	8.8	38.1	1.3	2-4241	.33	
	3/8 AN	10.0	16.0	1.4	2-4207	.06	
	CLEVIS	10.0	20.5	2.5	1-2034	.29	
	MS814	10.2	20.7	1.4	2-4265	.07	
	3/8 FENDER	10.2	38.1	1.5	2-4242	.33	
	STRIKER	10.3	25.2	3.0	1-2040	2.50	
	10MM SMALL	10.5	17.6	1.4	1-2005	.13	
	10MM STAND	10.5	19.8	1.9	1-2013	.13	
	10MM LARGE	10.7	29.7	2.3	1-2021	.39	
	12 MM	CLEVIS	12.0	25.0	3.0	1-2035	.39
CRANK - MOD		12.2	38	6.3	2-4712	10.70	
7/16 STAND		12.5	28.4	1.3	2-4220	.18	
12MM SMALL		13.0	20.7	1.9	1-2006	.18	
12MM STAND		13.0	24.0	2.2	1-2014	.19	
MS817		13.0	32.0	1.9	2-4232	.23	
12MM LARGE		13.0	36.1	2.3	1-2022	.59	
1/2 AN		13.1	22.2	1.3	2-4209	.11	
14 MM		1/2 FENDER	14.2	50.8	1.9	2-4243	.59
		MS819	14.4	34.8	2.5	2-4233	.39
	9/16 AN	15.0	26.9	1.5	2-4204	.19	
	14MM STAND	15.0	27.9	2.5	1-2025	.29	
	14MM LARGE	15.0	44.0	3.0	1-2026	.99	
	16 MM	5/8 AN	16.3	30.0	1.5	2-4210	.29
16MM SMALL		17.1	27.4	2.4	1-2007	.36	
16MM STAND		17.1	29.7	2.9	1-2015	.34	
MS820		17.4	33.3	2.0	2-4268	.32	
5/8 STAND		17.4	39.4	1.9	2-4222	.39	
16MM LARGE		17.4	50.0	2.9	1-2023	1.24	
18 MM	18MM STAND	19	34	3	1-2029	.39	
	20 MM	MS 822	21	38	2.9	2-4228	.59
		20MM STAND	21	37	3	1-2051	.40
20MM LARGE		22	60	4	1-2028	1.99	

FLAT WASHER ASSORTMENT: 1705 PIECES #3-3009 \$155.00



TOLL FREE ORDER LINE : 1-800-767-4781

# SMALL HEX (6 POINT)

STRONG AS GRADE 8 - MADE IN USA - POLISHED

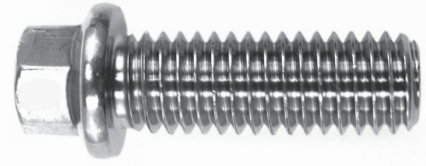
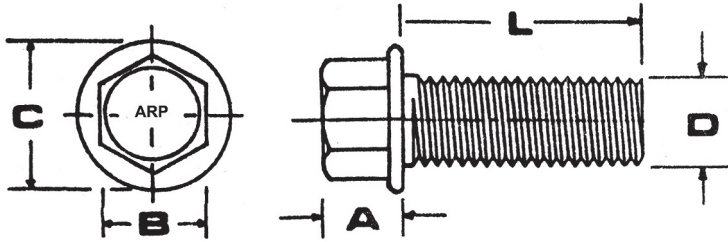

- SMALL FLANGE SHOWN -  
1/4 DIA THRU 1" LONG &  
5/16-7/16 THRU 1-1/4" LONG  
ARE FULLY THREADED

**DIMENSION TABLE (INCHES)**  
NOTE MANY SIZES ARE AVAILABLE IN TWO FLANGE DIAMETERS

D	DIAMETER	1/4	5/16		3/8		7/16	
A	HEAD HEIGHT	.25	.38	.28	.38	.31	.41	.41
B	WRENCH SIZE	5/16	3/8	3/8	3/8	3/8	7/16	1/2
C	FLANGE DIA	.52	.53	.63	.53	.63	.66	.78
THREADS/INCH		20	18	18	16	16	14	14

HEAD BOLTS: 7/16-14 X 2.180 # 2-0852 \$ 9.00  
(REDUCED SHANK) X 2.425 2-0854 9.90  
X 3.060 2-0855 10.75  
X 3.780 2-0856 12.00  
X 4.180 2-0858 13.25

### PART NUMBER AND PRICE GUIDE

SIZE	1/4-20		5/16-18				3/8-16				7/16-14			
FLANGE:	.52		.53		.63		.53		.63		.66		.78	
LENGTH	PART#	\$	PART#	\$	PART#	\$	PART#	\$	PART#	\$	PART#	\$	PART#	\$
1/2	2-0800	3.41							2-0844	3.80				
9/16					2-0810	3.97								
3/4	2-0804	3.58	2-0870	4.10	2-0813	4.10	2-0830	4.69	2-0880	4.69				
13/16	2-0805	3.60												
7/8					2-0815	4.20	*2-0831	6.15						
1	2-0806	3.66	2-8996	4.40	2-0816	4.40	2-0832	4.86	2-0881	4.86	2-0847	9.17	2-0898	9.17
1 1/4	2-0807	3.70			2-0817	4.64	2-0833	5.23	2-0882	5.23	2-8997	9.28	2-0878	9.28
1 1/2	2-0808	5.15			2-0818	6.21	2-0834	7.20	2-0883	7.20	2-8998	9.48	2-0879	9.48
1 3/4	2-0863	5.30			2-0819	6.53	2-0835	7.58	2-0884	7.58	2-8999	9.74	2-0867	9.74
2	2-0809	5.45	2-0820	6.80	2-0871	6.80			2-0885	7.87	2-8990	9.97	2-0887	9.97
2 1/4	2-0802	5.55			2-0821	6.93			2-0886	8.20	2-8991	10.44	2-0873	10.44
2 3/8							2-0837	8.16						
2 1/2	2-0803	5.68			2-0822	7.16			2-0838	8.50	2-8886	10.95	2-0899	10.95
2 3/4	2-0811	5.78			2-0823	7.33			2-0839	8.73			2-0896	11.60
3	2-0812	5.90			2-0824	7.62			2-0840	9.00	2-8993	12.57	2-0869	12.57
3 1/4					2-0825	7.81			2-0841	9.24			2-0890	12.96
3 1/2	2-0891	6.16			2-0826	7.89			2-0842	10.47	2-8995	13.53	2-0897	13.53
3 3/4					2-0827	8.05			2-0843	10.55			2-0872	14.27
4	2-0894	6.42			2-0814	8.30			2-0864	10.60	2-0857	14.78	2-0874	14.78
4 1/4					2-0862	8.48			2-0859	10.65			2-0875	14.87
4 1/2	2-0895	8.10			2-0861	8.71			2-0865	10.73	2-8894	15.18	2-0892	15.18
4 3/4					2-0829	9.27			2-0845	10.97			2-0866	15.60
5					2-0828	9.41			2-0846	11.15	2-0860	16.45		

ADDITIONAL SIZES: 12-24 X 1 7/8 2-0877 \$ 5.60  
12-24 X 2 1/2 2-0876 5.65

\*DRILLED FOR 0.032 DIA SAFETY WIRE:  
.032 SAFETY WIRE: 2-9900 \$.35/FT (10 FT MIN)

EXTRA SMALL HEAD BOLTS: (5/16" WRENCH)  
3/8-16 X 3/4 2-0888 \$ 4.40  
3/8-16 X 1 2-0889 4.50

**- SEE PAGE 96 FOR FINE THREAD -**

**SMALL HEX (6PT) SHOP ASSORTMENT: 400 PIECES # 3-3014 \$ 1883.50**  
**PERSONAL SIZE ASSORTMENT: 250 PIECES # 3-3137 \$ 1142.50**



# SMALL HEX (SIX POINT)

STRONGER THAN GRADE 8 - MADE IN USA - POLISHED

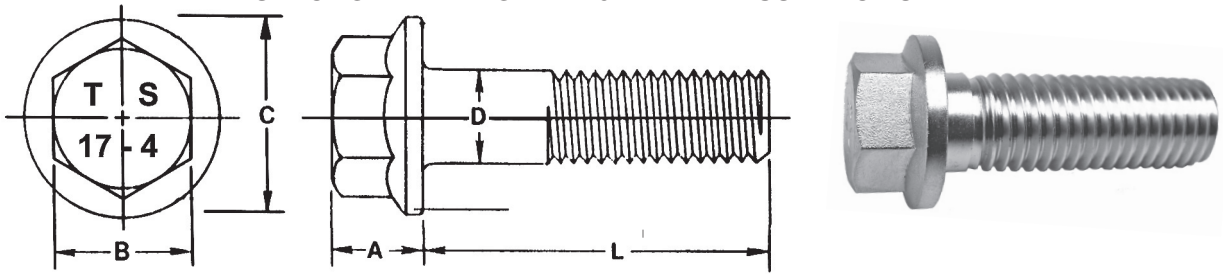

1/2 DIA THRU 6" LONG  
ARE MADE BY ARP  
ALL OTHER SIZES ARE  
CUSTOM MADE FOR  
US AND ARE STAMPED  
TS 17-4

**DIMENSION TABLE (INCHES)**

D	DIAMETER	1/2	9/16	5/8	3/4	3/4
A	HEAD HEIGHT	.39	.46	.51	.51	.57
B	WRENCH SIZE	9/16	5/8	3/4	3/4	13/16
C	FLANGE DIA.	.80	.93	1.07	1.07	1.19
THREADS/INCH		13	12	11	18	10

**PART NUMBER AND PRICE GUIDE**

SIZE	1/2-13		9/16-12		5/8-11		5/8-18		3/4-10		3/4-16	
LENGTH	PART#	\$	PART#	\$	PART#	\$	PART#	\$	PART#	\$		
1	2-3503	8.43										
1 1/4	2-3504	8.99										
1 1/2	2-3505	9.58	2-3560	29.00			2-8731	46.00			2-8750	79.18
1 3/4	2-3506	10.15	2-3561	34.00			2-8732	48.50				
2	2-3507	10.69	2-3520	38.50	2-3531	50.25	2-8733	50.50	2-3550	75.10	2-8752	80.00
2 1/4	2-3508	11.23	2-3562	41.30	2-3571	50.50	2-8734	50.70	2-3551	76.61	2-8753	80.10
2 1/2	2-3509	11.83	2-3521	42.00	2-3532	51.00	2-8735	51.10			2-8744	81.25
2 3/4	2-3510	12.39	2-3563	42.80	2-3573	51.50	2-8736	51.50				
3	2-3511	12.95	2-3522	43.50	2-3533	51.75	2-8737	51.80	2-3552	77.55	2-8746	81.75
3 1/4	2-3512	13.47	2-3564	45.75	2-3565	51.85	2-8738	52.00				
3 1/2	2-3513	14.10	2-3523	48.20	2-3534	52.00	2-8739	52.15			2-8747	82.25
3 3/4	2-3514	14.65	2-3568	49.90	2-3541	52.20	2-8740	52.50	2-3554	78.15		
4	2-3515	15.23	2-3524	51.90	2-3535	52.40	2-8741	52.80				
4 1/4	2-3581	15.80	2-3525	53.60	2-3577	53.00						
4 1/2	2-3516	16.38	2-3526	54.90	2-3536	53.50	2-8743	54.00	2-3555	80.75		
4 3/4	2-3496	17.21	2-3567	56.00								
5	2-3517	17.52	2-3527	57.70	2-3537	56.00	2-8745	56.00	2-3556	81.25		
5 1/2	2-3501	20.05	2-3566	58.90	2-3574	59.00	2-8756	59.00	2-3557	82.25		
6	2-3518	22.65	2-3549	59.90	2-3538	62.15	2-8757	62.15	2-3558	83.28		
6 1/2	2-3569	23.48	2-3528	60.90	2-3578	63.00						
7	2-3570	24.00			2-3539	64.00			2-3559	84.30		
7 1/2	2-3502	24.51			2-3582	65.00						
8	2-3572	25.00	2-3529	73.10	2-3540	66.00						
8 1/2	2-3575	25.55			2-3545	67.00						
9	2-3519	26.00			2-3542	68.90						
9 1/2					2-3583	71.50						
10	2-3548	26.67	2-3530	75.00	2-3543	73.00						
10 1/2					2-3544	75.65						
12					2-3547	77.00						
14					2-3576	80.00						
17					2-3579	85.00						

\*\* ADDITIONAL SIZES: 9/16-18 x 1 1/2 # 2-8726 \$ 30.00  
 9/16-18 X 3 1/2 # 2-8722 \$ 49.50  
 9/16-18 X 5 1/2 # 2-8728 \$ 59.10

**GREAT FOR USE AS SUSPENSION BOLTS!**

# SMALL HEX (SIX POINT)

STRONG AS GRADE 8 - MADE IN USA - POLISHED

**-FINE THREAD-**

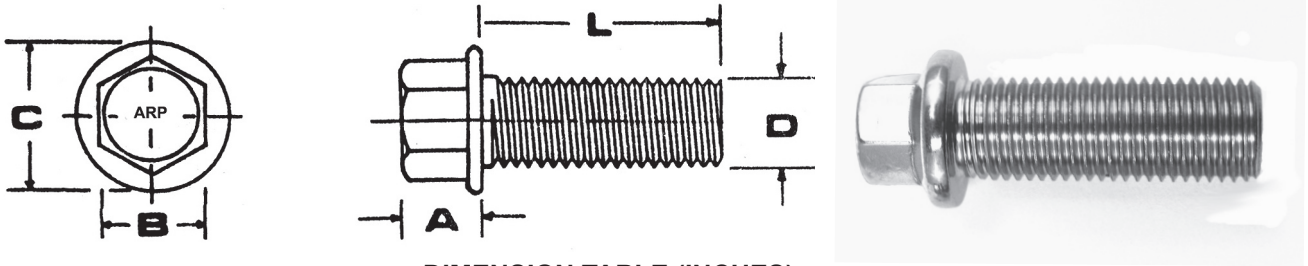

**DIMENSION TABLE (INCHES)**

D	DIAMETER	1/4	5/16	3/8	7/16	1/2
A	HEAD HEIGHT	.25	.28	.31	.41	.39
B	WRENCH SIZE	5/16	3/8	3/8	7/16	9/16
C	FLANGE DIA.	.52	.63	.63	.66	.80
THREADS/INCH		28	24	24	20	20

**PART NUMBER AND PRICE GUIDE**

SIZE	1/4-28		5/16-24		3/8-24		7/16-20		1/2-20	
LENGTH	PART#	\$	PART#	\$	PART#	\$	PART#	\$	PART#	\$
1/2	2-8800	3.41								
9/16			2-8821	3.98						
3/4	2-8802	3.53	2-0850	4.07	2-0853	4.51				
1	2-8804	3.72	2-8824	4.51	2-8843	4.67	2-8861	6.08	2-8703	9.30
1 1/4	2-8805	3.78	2-8825	4.90	2-8844	5.16	2-8862	7.51	2-8704	9.89
1 3/8							2-0848	7.54		
1 1/2	2-8806	4.90	2-8826	6.35	2-8845	7.20	2-8863	7.82	2-8705	10.54
1 5/8							2-0849	8.14		
1 3/4	2-8807	5.28	2-8827	6.56	2-8846	7.58	2-8864	8.43	2-8706	11.11
2	2-8808	5.43	2-8828	6.80	2-8847	7.89	2-0851	9.48	2-8707	11.66
2 1/4	2-8809	5.50	2-8829	6.97	2-8848	8.20	2-8866	10.00	2-8708	12.38
2 1/2	2-8810	5.61	2-8830	7.15	2-8849	8.39	2-0868	10.45	2-8709	13.04
2 3/4	2-8811	5.67	2-8831	7.43	2-8850	8.66	2-8867	10.96	2-8710	13.60
3	2-8812	5.82	2-8832	7.58	2-8851	9.08	2-8868	11.96	2-8711	14.16
3 1/4			2-8833	7.81					2-8712	14.72
3 1/2	2-8814	6.46	2-8834	7.91	2-8853	9.71	2-8869	12.93	2-8713	15.51
4	2-8816	6.71	2-8836	8.47	2-8855	10.20	2-8870	13.80	2-8715	16.78
4 1/2	2-8818	7.10	2-8838	9.20	2-8857	10.73	2-8872	14.58	2-8716	17.90
5			2-8840	9.89	2-8859	11.11	2-8874	15.00	2-8717	19.27
5 1/2									2-8718	22.33
6									2-8719	30.16
6 1/2*									2-8720	30.70
7*									2-8721	31.35
7 1/2*									2-8723	32.12
8*									2-8724	32.86

\* BOLTS LONGER THAN 6" ARE FORGED FROM 17-4 PH - MARKED TS - STRONGER THAN GRADE 8

**SMALL HEX (6 POINT)- FINE THREAD SHOP ASSORTMENT: 388 PIECES # 3-3069 \$ 1838.60**

**KNURLED SIX POINT BOLTS:**

7/16-20 X 2	# 8-2150	\$ 13.25
7/16-20 X 2 1/4	8-2151	14.50
7/16-20 X 2 1/2	8-2152	15.00
1/2-20 X 2 1/4	8-2161	16.75

# TWELVE POINT

STRONG AS GRADE 8 - MADE IN USA - POLISHED

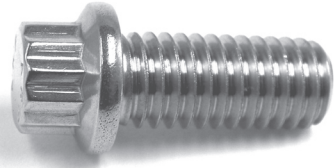
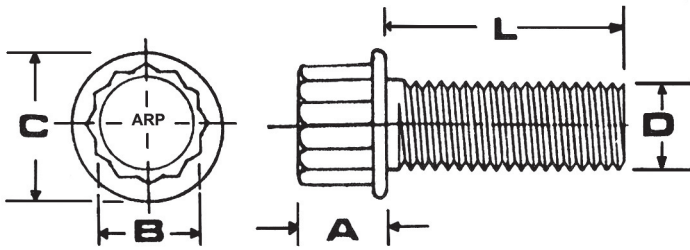

- 1/4 DIA THRU 1" LONG & 5/16-7/16 THRU 1-1/4" LONG ARE FULLY THREADED

DIMENSION TABLE (INCHES)

\*NOTE MANY SIZES ARE AVAILABLE IN TWO FLANGE DIAMETERS\*

D	DIAMETER	1/4	5/16	3/8	7/16	1/2			
A	HEAD HEIGHT	.25	.38	.28	.38	.31	.41	.41	.46
B	WRENCH SIZE	5/16	3/8	3/8	3/8	3/8	7/16	1/2	9/16
C	FLANGE DIA	.52	.53	.63	.53	.63	.66	.78	.84
	THREADS/INCH	20	18	18	16	16	14	14	13

## PART NUMBER AND PRICE GUIDE

SIZE	1/4-20		5/16-18		3/8-16		7/16-14		1/2-13					
FLANGE:	.52		.63		.53		.63		.66		.78		.84	
LENGTH	PART#	\$	PART#	\$	PART#	\$	PART#	\$	PART#	\$	PART#	\$	PART#	\$
1/2	2-3800	3.70					2-3879	4.14						
9/16			2-3810	4.18										
3/4	2-3804	3.97	2-3813	4.35	2-3830	4.90	2-3880	4.90						
13/16	2-3805	4.18												
7/8			2-3815	4.51	*2-3831	6.45								
1	2-3806	4.32	2-3816	4.68	2-3832	5.20	2-3881	5.20	2-3847	8.56	2-3877	8.56	2-3622	9.27
1 1/4	2-3807	4.51	2-3817	4.86	2-3833	5.50	2-3882	5.50	2-3801	8.64	2-3869	8.64	2-3623	9.89
1 1/2	2-3808	6.05	2-3818	6.88	2-3834	7.40	2-3883	7.40			2-3868	9.62	2-3624	10.54
1 3/4	2-3857	6.22	2-3819	7.17	2-3835	7.95	2-3884	7.95			2-3863	9.75	2-3625	11.14
2	2-3802	6.29	2-3871	7.56	2-3836	8.30	2-3885	8.30			2-3864	10.30	2-3626	11.76
2 1/4	2-3855	6.37	2-3821	7.81			2-3886	8.57			2-3888	10.80	2-3627	12.35
2 3/8					2-3837	8.54								
2 1/2	2-3854	6.50	2-3822	7.90			2-3838	8.70			2-3865	11.35	2-3628	13.00
2 3/4	2-3853	6.58	2-3823	8.05			2-3839	9.26			2-3896	11.60	2-3629	13.63
3	2-3812	6.71	2-3824	8.36			2-3840	9.52			2-3889	12.82	2-3630	14.25
3 1/4			2-3825	8.51			2-3841	9.85			2-3890	13.55	2-3631	14.82
3 1/2	2-3891	7.05	2-3826	8.66			2-3842	10.12			2-3897	14.00	2-3632	15.51
3 3/4			2-3827	8.80			2-3843	10.35			2-3867	14.30	2-3633	16.12
4	2-3894	7.43	2-3859	9.46			2-3860	10.70			2-3898	15.75	2-3634	16.75
4 1/4			2-3858	9.53			2-3861	10.91			2-3876	15.84	2-3635	17.38
4 1/2	2-3895	8.41	2-3814	9.58			2-3862	11.11			2-3899	15.92	2-3636	18.00
4 3/4							2-3851	11.38			2-3878	16.00	2-3637	18.81
5			2-3828	9.81			2-3845	11.65	2-3887	16.35			2-3638	19.27
5 1/2									2-3873	17.30			2-3640	22.11
6									2-3875	18.30			2-3642	30.42

**5/16-18 BOLTS WITH SMALL .53 FLANGE**

5/16-18 X 3/4" # 2-3870 \$ 7.16

5/16-18 X 2" 2-3820 8.39

**3/8-16 BOLTS WITH 7/16 WRENCH HEAD .67 FLANGE**

3/8-16 X 2" 2-3685 8.28

3/8-16 X 2 1/2" 2-3687 8.58

**\*DRILLED FOR SAFETY WIRE**

.032 SAFETY WIRE: 2-9900 \$.35/FT (10 FT MIN)

SPECIAL HEAD BOLTS: 7/16-14 X 2.180 # 2-3872 \$ 9.80

(MAY HAVE REDUCED SHANKS) 2.425 2-3856 10.75

3.060 2-3866 11.57

4.180 2-3852 13.87

**TWELVE POINT SHOP ASSORTMENT: 400 PIECES # 3-3015 \$ 2019.90**

**PERSONAL ASSORTMENT: 250 PIECES # 3-3138 \$ 1230.50**

# TWELVE POINT

STRONG AS GRADE 8 - MADE IN USA - POLISHED  
- FINE THREAD -

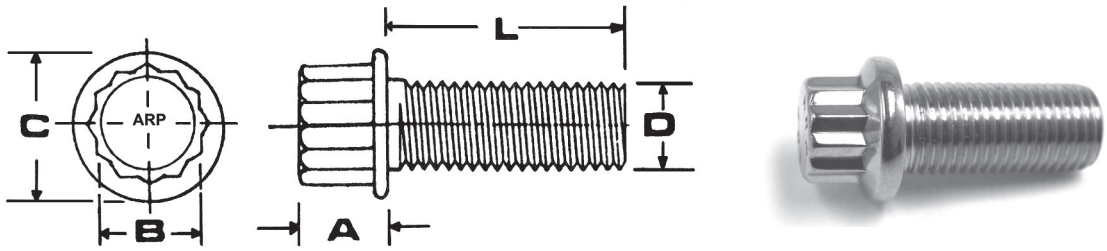

**DIMENSION TABLE (INCHES)**

D	DIAMETER	1/4	5/16	3/8	7/16	1/2
A	HEAD HEIGHT	.25	.28	.31	.41	.46
B	WRENCH SIZE	5/16	3/8	3/8	7/16	9/16
C	FLANGE DIA.	.52	.63	.63	.66	.84
THREADS/INCH		28	24	24	20	20

**PART NUMBER AND PRICE GUIDE**

SIZE	1/4-28		5/16-24		3/8-24		7/16-20		1/2-20	
	PART#	\$	PART#	\$	PART#	\$	PART#	\$	PART#	\$
1/2	2-3900	3.70								
9/16			2-3921	4.31						
3/4	2-3902	3.90	2-3811	4.51	2-3844	4.97				
1	2-3904	4.24	2-3809	4.75	2-3943	5.20	2-3960	6.22	2-3980	9.28
1 1/4	2-3905	4.28	2-3925	4.86	2-3944	5.50	2-3961	7.66	2-3981	9.89
1 3/8							2-3849	7.89		
1 1/2	2-3906	6.12	2-3926	6.71	2-3945	7.38	2-3962	8.11	2-3982	10.54
1 5/8							2-3846	8.30		
1 3/4	2-3907	6.00	2-3927	7.00	2-3946	7.69	2-3963	8.50	2-3983	11.17
2	2-3908	6.12	2-3928	7.28	2-3947	8.30	2-3848	9.48	2-3984	11.66
2 1/4	2-3909	6.17	2-3929	7.61	2-3948	8.55	2-3964	9.83	2-3985	12.38
2 1/2	2-3910	6.33	2-3930	7.70	2-3949	8.68	2-3850	10.45	2-3986	13.00
2 3/4	2-3911	6.45	2-3931	7.90	2-3950	9.15	2-3965	11.30	2-3987	13.60
3	2-3912	6.51	2-3932	8.06	2-3951	9.42	2-3966	11.94	2-3988	14.17
3 1/2	2-3914	6.75	2-3934	8.40	2-3953	10.00	2-3968	12.62	2-3990	15.51
4	2-3916	7.25	2-3936	9.20	2-3955	10.50	2-3970	13.57	2-3992	16.77
4 1/2	2-3918	7.88	2-3938	9.38	2-3957	10.87	2-3972	14.59	2-3994	17.90
5			2-3940	9.61	2-3959	11.40	2-3974	15.10	2-3996	19.27
5 1/2									2-3997	22.33
6									2-3999	30.15

**TWELVE POINT - FINE THREAD SHOP ASSORTMENT: 300 PIECES # 3-3071 \$ 1938.60**

**KNURLED TWELVE POINT BOLTS:** 7/16-20 X 2 # 8-2163 \$ 12.85  
7/16-20 X 2 1/4 8-2164 13.75



**TOLL FREE ORDER LINE : 1-800-767-4781**



# CARRIAGE BOLTS

## US COARSE THREAD - LOW STRENGTH

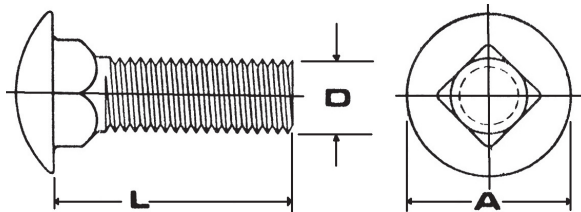

**DIMENSION TABLE (INCHES)**

D	DIAMETER	3/16 (#10)	1/4	5/16	3/8	7/16	1/2	5/8
A	HEAD DIA.	.45	.58	.71	.81	.92	1.06	1.25
	THREADS/INCH	24	20	18	16	14	13	11

### POLISHED CARRIAGE BOLTS:

TO ORDER CARRIAGE BOLTS, ADD A (P) TO THE PART NUMBER, AS AN EXAMPLE 2-0700P, THE EXTRA COST FOR POLISHING IS:

SIZE:	PRICE:	SIZE:	PRICE:
#10	\$.85 EACH	7/16"	\$ 1.50 EACH
1/4"	.95 "	1/2"	2.00 "
5/16"	1.00 "	5/8"	2.50 "
3/8"	1.25 "		

### PART NUMBER AND PRICE GUIDE

DIAMETER	3/16 (#10)	1/4	5/16	3/8	7/16*	1/2	5/8							
LENGTH	PART#	\$	PART#	\$	PART#	\$	PART#	\$	PART#	\$	PART#	\$	PART#	\$
1/2	2-0760	.33	2-0700	.23										
5/8	2-0761	.35	2-0701	.25										
3/4	2-0762	.35	2-0702	.25	2-0715	.43	2-0728	.75						
1	2-0763	.38	2-0703	.27	2-0716	.45	2-0729	.85	2-0741	2.95	2-0742	1.79		
1 1/4	2-0764	.40	2-0704	.29	2-0717	.47	2-0730	.95	2-0754	3.15	2-0743	1.88		
1 1/2	2-0765	.42	2-0705	.35	2-0718	.49	2-0731	1.04	2-0755	3.50	2-0744	1.99		
1 3/4			2-0706	.44	2-0719	.59	2-0732	1.14			2-0745	2.19	2-7702	7.70
2	2-0713	.75	2-0707	.48	2-0720	.63	2-0733	1.19	2-0756	10.05	2-0746	2.40		
2 1/4			2-0708	.56	2-0721	.69	2-0734	1.26			2-0747	2.69		
2 1/2	2-7720	.79	2-0709	.62	2-0722	.75	2-0735	1.54	2-0771	10.25	2-0748	2.85		
2 3/4			2-7724	.64	2-7727	.79								
3			2-0710	.65	2-0723	.84	2-0736	1.59	2-0767	10.45	2-0749	3.00	2-0777	7.90
3 1/2			2-0711	.77	2-0724	.96	2-0737	1.66			2-0750	3.16	2-0792	8.50
4			2-0712	.89	2-0725	.99	2-0738	1.79	2-0769	10.75	2-0751	3.38	2-0793	8.90
4 1/2			2-7725	.99	2-7728	1.23	2-0757	1.88	2-0770	10.84	2-0774	3.95		
5			2-7726	1.39	2-0726	1.44	2-0739	1.99	2-0787	11.10	2-0752	4.40		
5 1/2							2-0758	2.26	2-0779	11.23				
6					2-0727	3.76	2-0740	2.39	2-0788	11.45	2-0753	4.80	2-0797	12.90
6 1/2							2-0796	6.80						
7							2-0759	5.50			2-0714	9.90	2-0776	13.80
8					2-7732	4.99	2-0766	5.60			2-0775	10.50		
9							2-0791	6.98			2-0785	10.75		
10							2-0781	7.60			2-0780	11.90		
12							2-0783	8.95			2-0782	11.95		



\* 7/16 X 1, 1 1/4 BOLT HAVE A SHORT HEIGHT SQUARE (APPROX. 1/8"), 7/16 X 2 AND LONGER ARE HOT FORGED

\*\*FINE THREAD - 7/16-20 X 1 1/2 CARRIAGE # 2-0786 \$ 12.95 \*\*

\*\* HIGH STRENGTH (17- 4 PH) 3/8-24 X 4      2-0790      \$ 26.00  
 3/8-24 X 2      2-0789      25.00

**CARRIAGE BOLT SHOP ASSORTMENT: 515 PIECES # 3-3008 \$ 240.50**

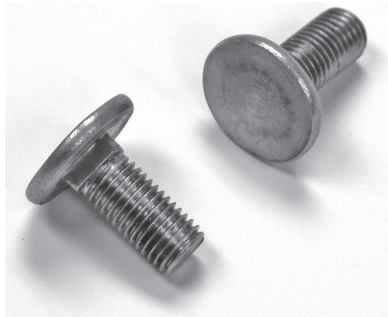

## REAR FENDER BOLTS FOR STEPSIDE FORD TRUCKS!

- MADE FOR AFTERMARKET BEDSIDES WITH SQUARE HOLES.  
 SPECIAL FLAT HEAD WITH SHORT HEIGHT SQUARE.  
 ALSO AVAILABLE IN KITS FOR FORD TRUCKS! -

5/16-24 x 11/16 (WITH SQUARE) # 2-0773 \$ 2.99

# BUTTON HEAD CAP SCREWS

- LOW STRENGTH - SEE PAGE 2 FOR HIGH STRENGTH -

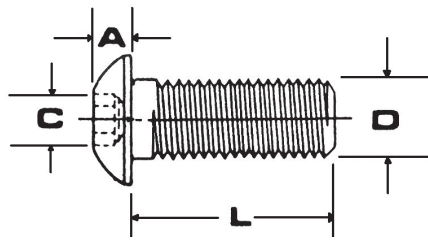
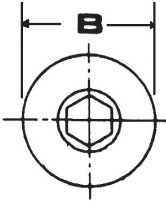

**SEE PAGE 2 FOR HIGH STRENGTH (GRADE 8+) BUTTON HEADS**

**DIMENSION TABLE (INCHES)**

D	DIAMETER	1/4	5/16	3/8	7/16	1/2	5/8
A	HEAD HT.	.13	.16	.19	.19	.26	.32
B	HEAD DIA.	.44	.55	.66	.66	.87	1.0
C	KEY SIZE	5/32	3/16	7/32	7/32	5/16	3/8
THREADS/INCH		20	18	16	14	13	11

**PART NUMBER AND PRICE GUIDE**

**\*\* SPECIFY APPLICATION ON ALL 7/16" AND LARGER SIZES \*\***

SIZE	1/4-20		5/16-18		3/8-16		7/16-14 **		1/2-13 **		5/8-11 **	
LENGTH	PART#	\$	PART#	\$	PART#	\$	PART#	\$	PART#	\$	PART#	\$
3/8	2-0536	.18	2-5513	.29								
1/2	2-0537	.19	2-0555	.32	2-0563	.49						
5/8	2-0538	.20	2-0556	.34	2-0564	.53						
3/4	2-0539	.22	2-0557	.39	2-0565	.56						
7/8	2-0540	.24										
1	2-0541	.24	2-0559	.45	2-0567	.65	2-0491	2.69	2-0572	1.49		
1 1/4	2-0542	.29	2-0560	.52	2-0568	.69	2-0492	2.79	2-0573	1.69		
1 1/2	2-0543	.31	2-0561	.58	2-0569	.78	2-0493	2.89	2-0574	1.86	2-0479	6.99
1 3/4	2-0554	.39	2-0595	.69	2-0571	.90						
2	2-0544	.43	2-0562	.78	2-0570	1.09			2-0575	2.40		
2 1/4	2-0549	.59	2-0478	.99	2-0498	1.19						
2 1/2	2-0598	.67	2-0589	1.09	2-0596	1.49			2-0576	3.74		
2 3/4	2-5501	.79	2-5507	1.15	2-0577	1.69						
3	2-0599	.90	2-0592	1.19	2-0597	1.90			2-0499	4.85		
3 1/4			2-5521	2.95								
3 1/2	2-0496	1.50	2-0558	1.57	2-0591	2.90						
3 3/4					2-5527	4.90						
4	2-0494	1.99	2-0566	1.95	2-0593	3.60			2-0581	6.70		
4 1/2	2-5502	2.46	2-5508	2.70	2-5514	10.40						
5	2-5504	2.76	2-5510	3.30	2-0488	12.98			2-5518	18.80		
6	2-5506	3.33	2-5512	4.10	2-5516	15.60						

**BUTTON HEAD SHOP ASSORTMENT: 625 PIECES # 3-3003 \$ 255.50**  
**PERSONAL ASSORTMENT: 500 PIECES 3-3150 127.75**

## TRUSS SOCKET MACHINE SCREWS

**\*BUTTON HEADS WITH BIGGER HEADS! GREAT FOR HANGING REAR FENDERS ON STEPSIDE TRUCKS!**

SIZE:	12-24		1/4-20		5/16-18	
HEAD DIAMETER	.50		.57		.64	
LENGTH	PART#	\$	PART#	\$	PART#	\$
1/2	2-3076	.39	2-3137	.49		
5/8			2-3350	.52		
3/4	2-3103	.44	2-3185	.54	2-3195	.86
1	2-3116	.49	2-3191	.59	2-3196	.93
1 1/4					2-3327	.99

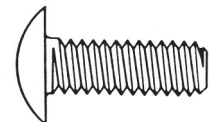
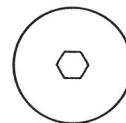

**TOLL FREE ORDER LINE : 1-800-767-4781**

# BUTTON HEAD CAP SCREWS

-SMALL SIZES AND FINE THREAD - LOW STRENGTH-

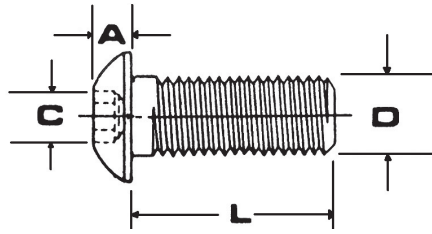
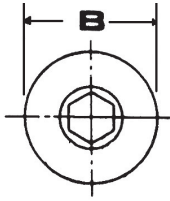

**DIMENSION TABLE (INCHES)**

D	DIAMETER		.112	.138	.164	.190	.190	1/4	5/16	3/8	1/2
A	HEAD HT.		.055	.07	.08	.10	.10	.13	.16	.19	.26
B	HEAD DIA.		.21	.26	.31	.36	.36	.44	.55	.66	.87
C	KEY SIZE		1/16	5/64	3/32	1/8	1/8	5/32	3/16	7/32	5/16
	ISO #	2	4	6	8	10	10				
	THREADS/INCH	56	40	32	32	24	32	28	24	24	20

**PART NUMBER AND PRICE GUIDE**

SIZE	2-56		4-40		6-32		8-32		10-24		10-32	
LENGTH	PART#	\$	PART#	\$	PART#	\$	PART#	\$	PART#	\$	PART#	\$
3/16	2-0480	.06										
1/4	2-5500	.07	2-0500	.05	2-0506	.05	2-0512	.06	2-0518	.10	2-0527	.12
5/16			2-5528	.09			2-5540	.07				
3/8			2-0501	.06	2-0507	.06	2-0513	.08	2-0519	.11	2-0528	.11
1/2			2-0502	.07	2-0508	.07	2-0514	.09	2-0520	.12	2-0529	.18
5/8			2-0503	.08	2-0509	.08	2-0515	.10	2-0521	.13	2-0530	.19
3/4			2-0504	.09	2-0510	.09	2-0516	.11	2-0522	.14	2-0531	.20
1			2-0505	.12	2-0511	.10	2-0517	.15	2-0523	.16	2-0532	.22
1 1/4					2-0476	.14	2-0477	.18	2-0524	.20	2-0533	.24
1 1/2					2-0490	.19	2-0497	.21	2-0525	.23	2-0534	.26
2							2-0553	.29	2-0526	.36	2-0535	.40
2 1/2									2-0495	.59		

**PART NUMBER AND PRICE GUIDE**

SIZE	1/4-28		5/16-24		3/8-24		1/2-20 **	
LENGTH	PART#	\$	PART#	\$	PART#	\$	PART#	\$
3/8	2-0545	.27	2-5541	.54				
1/2	2-0546	.29	2-0587	.59				
5/8	2-0547	.32	2-0586	.64				
3/4	2-0548	.33	2-0580	.69	2-0579	1.49		
7/8								
1	2-0550	.42	2-0582	.79	2-0594	1.58	2-0481	2.95
1 1/4	2-0551	.42	2-0583	.99	2-0578	1.76	2-0482	3.30
1 1/2	2-0552	.49	2-0584	1.19	2-0588	1.88	2-0483	3.70
1 3/4								
2			2-0485	1.49				

**NEW SIZES:**

5-40 X 1/2 # 2-5532 \$ .09  
 5-40 X 5/8 # 2-5533 \$ .09

**\*\* SPECIFY APPLICATION ON ALL 7/16" AND LARGER SIZES \*\***

**FINE THREAD BUTTON HEAD SHOP ASSORTMENT: 625 PIECES # 3-3042 \$ 360.00**  
**PERSONAL SIZE ASSORTMENT: 400 PIECES 3-3185 130.00**

SIZE:	#8 AB THREAD		#10 AB THREAD		#14 A THREAD	
LENGTH	PART#	\$	PART#	\$	PART#	\$
3/8	2-1970	.18				
1/2	2-1971	.19	2-1981	.29		
5/8	2-1973	.20	2-1982	.31	2-1990	.39
3/4	2-1974	.21	2-1984	.34	2-1991	.44
1	2-1976	.22	2-1986	.39	2-1992	.49

**BUTTON HEAD SHEET METAL SCREWS**

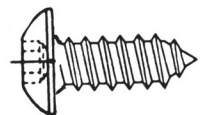
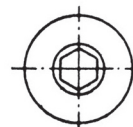

# FLAT SOCKET HEAD CAP SCREWS

- LOW STRENGTH -

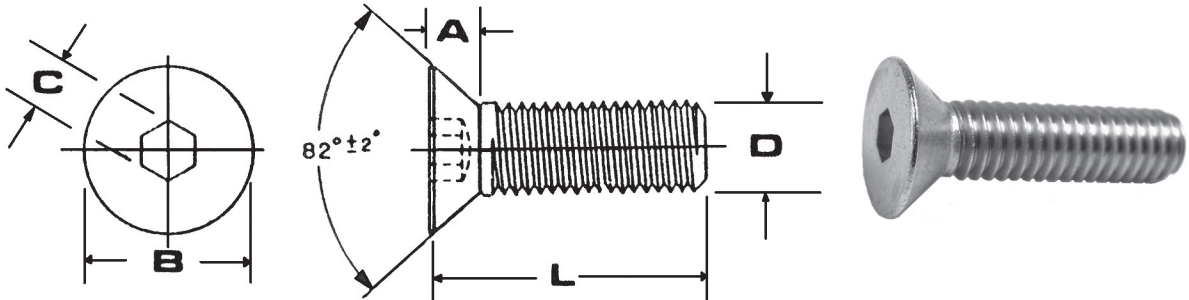

DIMENSION TABLE (INCHES)

D	DIAMETER	.112	.138	.164	.190	.190	.220	1/4	1/4	5/16	5/16	3/8	1/2
A	HEAD HT.	.08	.10	.11	.12	.12	.14	.16	.16	.19	.19	.23	.25
B	HEAD DIA.	.25	.30	.32	.38	.38	.42	.49	.49	.61	.61	.72	.88
C	KEY SIZE	1/16	5/64	3/32	1/8	1/8	1/8	5/32	5/32	3/16	3/16	7/32	5/16
	ISO #	4	6	8	10	10	12						
	THREADS/INCH	40	32	32	24	32	24	20	28	18	24	16	13

## PART NUMBER AND PRICE GUIDE

\*\* SPECIFY APPLICATION ON ALL 7/16" AND LARGER SIZES \*\*

SIZE	1/4-20		5/16-18		3/8-16		1/2-13 **	
LENGTH	PART#	\$	PART#	\$	PART#	\$	PART#	\$
3/8	2-6610	.18						
1/2	2-0640	.19	2-0656	.34	2-6612	.68		
5/8	2-0641	.22	2-0657	.37	2-0667	.69		
3/4	2-0642	.24	2-0658	.39	2-0668	.70		
7/8	2-0654	.25						
1	2-0643	.27	2-0659	.46	2-0669	.76	2-0677	1.90
1 1/4	2-0644	.30	2-0660	.59	2-0670	.82	2-0678	2.45
1 1/2	2-0645	.36	2-0661	.65	2-0671	.95	2-0679	2.49
1 3/4	2-0646	.39	2-0662	.76	2-0672	1.19	2-0680	2.80
2	2-0647	.45	2-0663	.79	2-0673	1.29	2-5633	3.20
2 1/2	2-0684	.58	2-0655	.83	2-0674	1.59	2-5634	3.70
3	2-0693	.79	2-0685	.99	2-0675	1.85	2-5635	4.60
3 1/2	2-0683	.98	2-5630	1.54	2-5632	2.98	2-5636	5.40
4	2-0611	1.49	2-0687	1.89	2-0676	3.48	2-0681	5.90
4 1/2	2-5637	6.20	2-5665	6.40	2-5668	6.90	2-5638	9.90
5	2-0639	6.70	2-5667	8.90	2-5669	10.30	2-5639	11.30

ADDITIONAL SIZE:  
5/8-11 X 2 #2-6613 \$5.80

WE WILL TURN  
DOWN THE HEADS  
ON ANY OF OUR  
STOCK FLAT  
SOCKETS TO MAKE  
JACKSON HEAD  
SCREWS - IF YOUR  
SIZE ISN'T LISTED  
- JUST GIVE US  
A CALL AT 800-767-  
4781

SPECIAL JACKSON HEAD:

5/16-18 X 7/8 WITH A .47 OD  
HEAD: 2-5664 \$3.99

**CUSTOM MADE HIGH STRENGTH FLAT SOCKETS:**  
MADE IN OUR SHOP FROM 17-4 PH HEAT TREATED (H-925)  
BAR STOCK - STRONGER AND MORE DUCTILE THAN GRADE 8  
STEEL

1/4-20 X 1	2-5650	\$16.00
5/16-18 X 1 1/4	2-5660	16.75
3/8-24 X 2 1/4	2-5629	19.80
7/16-14 X 1 1/4	2-0682	17.90
7/16-14 X 2	2-5612	19.90
1/2-20 X 1 3/4	2-5682	20.90

WE CAN MAKE THESE TO ORDER IN ANY SIZE FROM 12-24  
(6MM)THRU 9/16 (14MM) - COARSE OR FINE THREAD

## PART NUMBER AND PRICE GUIDE UNDERSIZED (JACKSON) HEAD

SIZE	1/4-20		5/16-18	
HEAD DIAMETER	.42 (#12)		.49 (1/4)	
LENGTH	PART#	\$	PART#	\$
5/8	2-5641	1.89	2-5656	2.08
3/4	2-5642	1.92	2-5657	2.17
1	2-5643	1.95	2-5658	2.27
1 1/4	2-5644	1.99	2-5659	2.36
1 1/2	2-5645	1.99	2-5661	2.45
2	2-5646	2.05	2-5662	2.69

FLAT SOCKET CAP SCREW SHOP ASSORTMENT: 635 PIECES # 3-3020 \$ 240.00  
PERSONAL ASSORTMENT: 500 PIECES 3-3155 132.50



# FLAT SOCKET HEAD CAP SCREWS

-SMALL SIZES AND FINE THREAD - LOW STRENGTH-

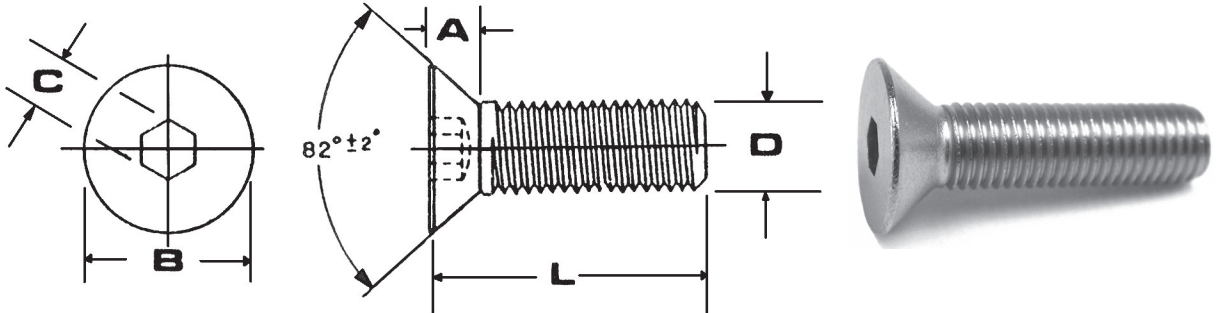

DIMENSION TABLE (INCHES)

D	DIAMETER	.112	.138	.164	.190	.190	.220	1/4	5/16	3/8
A	HEAD HT.	.08	.10	.11	.12	.12	.14	.16	.19	.23
B	HEAD DIA.	.25	.30	.32	.38	.38	.42	.49	.61	.72
C	KEY SIZE	1/16	5/64	3/32	1/8	1/8	1/8	5/32	3/16	7/32
ISO #		4	6	8	10	10	12			
THREADS/INCH		40	32	32	24	32	24	28	24	24

## PART NUMBER AND PRICE GUIDE

SIZE	4-40		6-32		8-32		10-24		10-32		12-24		1/4-28	
LENGTH	PART#	\$	PART#	\$	PART#	\$	PART#	\$	PART#	\$	PART#	\$	PART#	\$
1/4	2-6601	.06	2-6605	.07	2-6609	.08								
5/16	2-6602	.06												
3/8	2-0600	.06	2-0606	.07	2-0613	.08	2-0620	.09	2-0627	.09				
1/2	2-0601	.09	2-0607	.09	2-0614	.09	2-0621	.10	2-0628	.10	2-0636	.25	2-0648	.24
5/8	2-0602	.11	2-0608	.11	2-0615	.11	2-0622	.11	2-0629	.11	2-0634	.28	2-0649	.26
3/4	2-0603	.12	2-0609	.12	2-0616	.12	2-0623	.14	2-0630	.14	2-0635	.32	2-0650	.27
1	2-0604	.15	2-0610	.13	2-0617	.13	2-0624	.19	2-0631	.19	2-0637	.35	2-0651	.30
1 1/4					2-0618	.19	2-0625	.21	2-0632	.21			2-0652	.42
1 1/2					2-0619	.21	2-0626	.23	2-0633	.23			2-0653	.54
2					2-0689	.39	2-0690	.39	2-0691	.39			2-0697	1.29

ADDITIONAL SIZES: 5-40 X 1/2 2-6633 .08  
 BLACK FLAT SOCKET HEAD: 10-32 X 5/8 2-6672 .27  
 10-32 X 3/4 2-6673 .29

## PART NUMBER AND PRICE GUIDE UNDERSIZED (JACKSON) HEAD

SIZE	1/4-28		5/16-24		5/16-24	
HEAD DIAMETER	.42 (#12)		.42 (#12)		.49 (1/4)	
LENGTH	PART#	\$	PART#	\$	PART#	\$
1/2	2-5670	1.37	2-5686	1.93		
5/8	2-5671	1.39	2-5685	3.98		
3/4	2-5672	1.40	2-5687	1.99	2-5694	1.84
1	2-5673	1.43	2-5688	2.19	2-6611	1.99
1 1/4	2-5674	1.55	2-5689	2.44	2-0612	2.29
1 1/2	2-5675	1.67	2-5690	2.84	2-5695	2.69
2	2-5677	2.42	2-5691	3.29	2-5696	3.14

5/16-24 WITH THE EXTRA SMALL (.42 DIA) HEADS ARE USED ON EARLY 1930'S DOOR HINGES

5/16-24 WITH THE (.49 DIA) HEADS ARE FOUND ON 1950'S DOOR STRIKERS

## PART NUMBER AND PRICE GUIDE STANDARD HEAD SIZE

\*\* SPECIFY APPLICATION ON ALL 7/16" AND LARGER SIZES \*\*

SIZE	5/16-24		3/8-24		1/2-20 **	
LENGTH	PART#	\$	PART#	\$	PART#	\$
1/2	2-0686	.63				
5/8	2-5663	2.69				
3/4	2-0665	.69	2-0692	.99		
1	2-0664	.89	2-0694	1.38		
1 1/4	2-0666	1.14	2-0695	1.63		
1 1/2	2-0688	1.54	2-0696	1.75		
2	2-0698	1.99			2-0699	3.48

WE WILL TURN THE HEADS DOWN ON ANY OF OUR STOCK FLAT SOCKETS TO MAKE JACKSON HEAD SCREWS - IF YOUR SIZE ISN'T LISTED - JUST GIVE US A CALL AT 800-767-4781

FINE THREAD FLAT SOCKET SHOP ASSORTMENT: 665 PIECES # 3-3041 \$ 351.00  
 PERSONAL ASSORTMENT: 400 PIECES 3-3182 131.00

# HEX HEAD CAP SCREWS

-COARSE US THREADS - LOW STRENGTH-

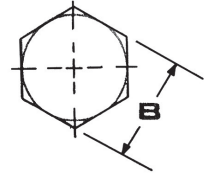
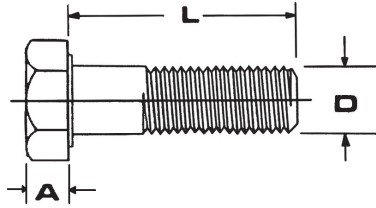
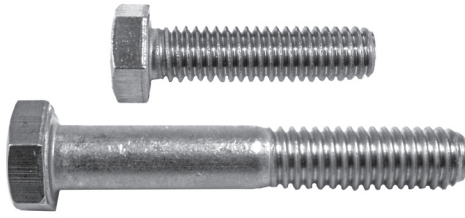

**DIMENSION TABLE (INCHES)**

D	DIAMETER	1/4	5/16	3/8	7/16	1/2	9/16	5/8	3/4
A	HEAD HT.	.156	.203	.234	.281	.313	.375	.391	.453
B	WRENCH	7/16	1/2	9/16	5/8	3/4	13/16	15/16	1 1/8
THREADS/INCH		20	18	16	14	13	12	11	10

**PART NUMBER AND PRICE GUIDE**

**\*\* SPECIFY APPLICATION ON ALL 7/16" AND LARGER SIZES \*\***

SIZE:	1/4-20		5/16-18		3/8-16		7/16-14**		1/2-13**		9/16-12**		5/8-11**		3/4-10**	
LENGTH	PART#	\$	PART#	\$	PART#	\$	PART#	\$	PART#	\$	PART #	\$	PART#	\$	PART#	\$
3/8	2-0100	.24	2-0013	.39	2-0221	.49										
1/2	2-0101	.29	2-0120	.41	2-0139	.55										
5/8	2-0102	.31	2-0121	.42	2-0140	.59										
3/4	2-0103	.32	2-0122	.46	2-0141	.66	2-0160	.99	2-0174	1.19						
7/8	2-0104	.35	2-0123	.51	2-0142	.69			2-0175	1.39						
1	2-0105	.36	2-0124	.54	2-0143	.74	2-0161	1.17	2-0176	1.52			2-0194	3.43		
1 1/4	2-0106	.42	2-0125	.59	2-0144	.81	2-0162	1.28	2-0177	1.66	2-3402	3.50	2-0195	3.64	2-0242	4.95
1 1/2	2-0107	.49	2-0126	.62	2-0145	.94	2-0163	1.39	2-0178	1.89	2-3403	3.90	2-0196	3.75	2-0241	5.20
1 3/4	2-0108	.52	2-0127	.68	2-0146	.99	2-0164	1.54	2-0179	2.03	2-0249	4.40	2-0197	3.87	2-0243	5.40
2	2-0109	.55	2-0128	.72	2-0147	1.14	2-0165	1.69	2-0180	2.14	2-0359	4.90	2-0198	4.12	2-3408	5.60
2 1/4	2-0110	.59	2-0129	.88	2-0148	1.32	2-0166	1.95	2-0181	2.25			2-0199	4.26	2-3400	5.90
2 1/2	2-0111	.69	2-0130	.96	2-0149	1.44	2-0167	2.18	2-0182	2.29	2-3429	5.20	2-0200	4.60	2-0244	6.20
2 3/4	2-0112	.75	2-0131	1.19	2-0150	1.54	2-0168	2.27	2-0183	2.57			2-0201	4.72		
3	2-0113	.79	2-0132	1.24	2-0151	1.59	2-0169	2.35	2-0184	2.68	2-0247	5.50	2-0202	4.78	2-0248	6.90
3 1/4	2-0114	.82	2-0133	1.29	2-0152	1.77	2-0214	2.45	2-0185	2.80			2-0203	4.89		
3 1/2	2-0115	.83	2-0134	1.39	2-0153	1.98	2-0170	2.54	2-0186	2.95			2-0204	4.98	2-0245	7.30
3 3/4	2-0116	.87	2-0135	1.59	2-0154	2.19			2-0187	3.35			2-0205	5.50		
4	2-0117	.89	2-0136	1.68	2-0155	2.25	2-0171	2.60	2-0189	3.88	2-0225	5.95	2-0206	5.60	2-0078	7.60
4 1/4					2-3438	2.39										
4 1/2	2-0118	.96	2-0137	1.77	2-0156	2.48	2-0220	2.90	2-0190	4.96			2-0207	5.79		
4 3/4					2-3433	2.66			2-3434	4.98						
5	2-0119	.98	2-0138	1.86	2-0157	2.79	2-0172	2.96	2-0191	5.29	2-0226	10.85	2-0208	5.96	2-0094	7.90
5 1/2	2-3413	1.59	2-0229	1.99	2-0158	2.88	2-0222	3.80	2-0192	5.48			2-0209	6.47		
6	2-3425	1.87	2-0223	2.07	2-0159	2.97	2-0173	4.30	2-0193	5.62	2-0095	11.90	2-0210	6.60		
6 1/2	2-3427	2.86			2-0219	3.10			2-3416	5.75			2-0228	6.77		
7	2-3428	2.98	2-0188	5.80	2-0211	3.86			2-0224	5.80			2-0227	7.21		
7 1/2	2-3436	3.78			2-3407	3.99			2-0218	5.99			2-0216	7.65		
8	2-3431	3.99	2-3405	6.10	2-3410	4.50			2-3411	6.60					2-0076	9.85
8 1/2			2-3432	8.98												
9					2-0212	4.95			2-0246	6.90			2-0213	7.90		
10					2-0268	5.40			2-0240	7.00						
13													2-3435	12.90		

**HEX TAP BOLTS - FULLY THREADED:**

- 5/16-18 X 2 # 2-3406 \$ .79
- 3/8-16 X 2 2-0074 .98
- 3/8-16 X 3 2-0215 1.25
- 3/8-16 X 3 1/2 2-3401 1.79
- 3/8-16 X 4 2-3437 1.98

**HEX HEAD COARSE THREAD ASSORTMENTS:**

- SHOP: 635 PIECES # 3-3002 \$ 295.00
- PERSONAL: 500 PIECES 3-3151 174.00

# HEX HEAD CAP SCREWS

-SMALL SIZES AND FINE THREAD - LOW STRENGTH-

## DIMENSION TABLE (INCHES)

<b>D</b>	<b>DIAMETER</b>	.112	.138	.164	.190	.216	1/4	5/16	3/8	7/16	1/2	5/8
<b>A</b>	<b>HEAD HT.</b>	.055	.086	.103	.112	.147	.156	.203	.234	.281	.313	.391
<b>C</b>	<b>WRENCH</b>	3/16	1/4	1/4	5/16	5/16	7/16	1/2	9/16	5/8	3/4	15/16
<b>ISO #</b>		4	6	8	10	12						
<b>THREADS/INCH</b>		40	32	32	24/32	24	28	24	24	20	20	18

**- MAY BE HEX OR INDENTED HEX - PART NUMBER AND PRICE GUIDE -**

ISO #	4-40		6-32		8-32		10-24		10-32		12-24	
LENGTH	PART#	\$	PART#	\$	PART#	\$	PART#	\$	PART#	\$	PART#	\$
1/4	2-0262	.09	2-0255	.09	2-0297	.13			2-0279	.23		
5/16	2-0251	.09	2-0256	.09					2-0280	.24		
3/8	2-0252	.09	2-0257	.09	2-0264	.13	2-0272	.24	2-0281	.24		
1/2	2-0253	.09	2-0258	.11	2-0265	.13	2-0273	.24	2-0282	.24	2-0289	.39
5/8	2-0254	.09	2-0259	.12	2-0266	.13	2-0274	.25	2-0283	.27		
3/4	2-0295	.09	2-0260	.14	2-0267	.15	2-0275	.27	2-0284	.27		
7/8			2-3423	.18					2-0285	.29		
1			2-0261	.20	2-0269	.18	2-0277	.33	2-0286	.33	2-0293	.49
1 1/4					2-0270	.19	2-0278	.36	2-0287	.36		
1 1/2			2-0276	.20	2-0271	.21	2-0292	.39	2-0288	.39		
1 3/4							2-0298	.48	2-3409	.49		
2							2-0299	.64	2-0250	.67		
2 1/2							2-0296	.69	2-3450	.77		
3							2-3424	.78	2-0294	.89		

### PART NUMBER AND PRICE GUIDE

\*\* SPECIFY APPLICATION ON ALL 7/16" AND LARGER SIZES \*\*

SIZE:	1/4-28		5/16-24		3/8-24		7/16-20**		1/2-20**		9/16-18**		5/8-18**	
LENGTH	PART#	\$	PART#	\$	PART#	\$	PART#	\$	PART#	\$			PART#	\$
3/8	2-0001	.25												
1/2	2-0002	.29	2-0015	.43	2-0028	.69								
5/8	2-0003	.32	2-0016	.45	2-0029	.74								
3/4	2-0004	.34	2-0017	.49	2-0030	.79	2-3481	1.38	2-0053	1.59				
7/8	2-0005	.36	2-3475	.55										
1	2-0006	.38	2-0019	.59	2-0032	.83	2-0044	1.49	2-0055	1.78			2-0065	4.88
1 1/4	2-0007	.44	2-0020	.69	2-0033	.92	2-0045	1.65	2-0056	1.99	2-0089	11.10	2-0066	5.07
1 1/2	2-0008	.49	2-0021	.78	2-0034	.99	2-0046	1.86	2-0057	2.09			2-0067	5.15
1 3/4	2-0009	.54	2-0022	.89	2-0035	1.06	2-0047	1.97	2-0058	2.19			2-0068	5.28
2	2-0010	.57	2-0023	.95	2-0036	1.19	2-0048	2.03	2-0059	2.39	2-0084	10.85	2-0069	5.39
2 1/4	2-0011	.62	2-0024	1.09	2-0037	1.38	2-0049	2.27	2-0060	2.64			2-3489	5.98
2 1/2	2-0012	.59	2-0025	1.19	2-0038	1.59	2-0050	2.36	2-0061	2.85			2-0086	6.60
2 3/4			2-0026	1.26	2-0039	1.74	2-3482	2.48	2-3485	2.99				
3	2-0014	.79	2-0027	1.29	2-0040	1.85	2-0052	2.59	2-0063	3.25			2-0087	7.20
3 1/4			2-0070	1.44					2-3486	3.36				
3 1/2	2-3470	.86	2-0073	1.59	2-0042	1.99	2-0368	2.98	2-0064	3.49			2-0075	7.90
4	2-0051	.98	2-3415	1.78	2-0043	2.35	2-3414	3.40	2-0062	3.98			2-0079	8.30
4 1/2			2-0077	1.97	2-0085	2.98	2-0366	3.80	2-3487	4.74			2-0031	8.30
5			2-3476	2.23	2-3478	3.49			2-0018	5.38			2-0041	8.89
6			2-3477	2.49										

5/16-24 X 1 1/2 HEX TAP BOLT - FULLY THREADED # 2-0000 \$ 0.59

5/16-24 X 2 1/2 HEX TAP BOLT - FULLY THREADED # 2-0054 \$ 1.29

**HEX HEAD FINE THREAD SHOP ASSORTMENT: 635 PIECES # 3-3018 \$ 340.00**  
**PERSONAL ASSORTMENT: 400 PIECES 3-3186 184.00**

# BLACK ORIGINAL STYLE STAINLESS FASTENERS

THESE ORIGINAL STYLE FASTENERS ARE REPRODUCED IN STAINLESS AND TREATED TO A PERMANENT BLACK FINISH. THIS EXCLUSIVE STAINLESS PRODUCT IS MADE FOR CUSTOMERS WHO WANT THE RESTORED LOOK WITHOUT THE RUST!

BLACK INDENTED HEX - NO FLANGE - MADE IN USA!										
	1/4-20		1/4-20		5/16-18		5/16-24		3/8-16	
	3/8 WRENCH		7/16 WRENCH		1/2 WRENCH		1/2 WRENCH		9/16 WRENCH	
LENGTH	PART#	\$	PART#	\$	PART#	\$	PART#	\$	PART#	\$
1/2			2-1861	2.85						
5/8	2-1860	2.80	2-1862	2.90	2-1850	2.90	2-1895	2.95		
3/4			2-1863	2.95	2-1851	2.95	2-1896	2.99	2-1853	3.10
1	2-1883	2.99			2-1852	3.25	2-1897	3.29	2-1854	3.40
1 1/4									2-1855	3.45
1 1/2									2-1886	3.50

BLACK INDENTED HEX WASHER HEAD				
	1/4-20 .50 OD FLANGE		5/16-18 .68 OD FLANGE	
LENGTH	PART#	\$	PART #	\$
1/2	2-1937	3.15	2-1856	3.30
5/8	2-1938	3.20	2-1857	3.35
3/4	2-1939	3.25	2-1858	3.40
1			2-1859	3.45

WITH 13/16 OD BIG FLANGE HEAD:  
 5/16-18 X 3/4 # 2-1894 \$ 3.75  
 5/16-24 X 3/4 2-1893 3.50



1/4-20 BLACK SERRATED FLANGE NUT # 2-1955 \$ .59  
 5/16-18 BLACK SERRATED FLANGE NUT 2-1864 .69  
 5/16-24 BLACK SERRATED FLANGE NUT 2-1967 .83

BLACK MACHINE SCREWS				
SIZE	LENGTH	DESCRIPTION	PART#	\$
10-24	3/4	HEX MACHINE SCREW	2-1956	.65
10-24	1/2	PHILLIPS FLAT HEAD	2-1952	.58
8-32	3/4	PHILLIPS PAN HEAD	2-1957	.59
10-24	5/8	PHILLIPS PAN HEAD	2-1954	.62
10-32	3/8	PHILLIPS PAN HEAD	2-1958	.59
1/4-20	1/2	PHILLIPS PAN HEAD	2-1953	.69
1/4-20	5/8	PHILLIPS ROUND	2-1951	.69
8-32	3/4	PHIL OVAL JACKSON	2-1959	.79
1/4-20	7/8	PHIL OVAL JACKSON	2-1950	1.15
8-32	1/2	PHILLIPS TRUSS	2-1960	.66
10-24	1/2	PHILLIPS TRUSS	2-1961	.67
5/16-18	3/4	PHILLIPS TRUSS	2-1962	1.05

BLACK WASHERS					
SIZE	O.D.	DESCRIPTION	T	PART#	\$
#6	3/6	MS805	.03	2-1919	.45
# 6	.625	#6 FENDER	.03	2-1844	.58
#6 C SK	.3125	#6 COUNTERSUNK	.03	2-1876	.61
# 8	.465	4 MM LARGE	.037	2-4284	.57
# 10	.4386	# 10 AN	.06	2-4258	.55
1/4	.50	1/4 AN	.06	2-4412	.59
1/4	.625	MS810	.062	2-4294	.59
1/4	.63	1/4 STANDARD	.04	2-4414	.59
1/4	.70	6 MM LARGE	.055	2-4298	.67
1/4	.75	1/4 HEAVY	.07	2-4295	.82
5/16	.73	MS811	.055	2-4290	.64
5/16	.85	5/16 HEAVY	.085	2-4296	.92
5/16	.935	8 MM LARGE	.075	2-4297	.87
5/16	1.25	5/16 FENDER	.060	2-4413	.86
3/8	.78	10MM STANDARD	.075	2-4291	.73
3/8	.875	MS813	.075	2-4411	.68
3/8	.99	3/8 HINGE	.115	2-4292	1.28
3/8	1.17	10 MM LARGE	.09	2-4293	1.10

BLACK SHEET METAL SCREWS				
SIZE	LENGTH	DESCRIPTION	PART#	\$
#8	1/2	INDENTED HEX	2-1944	.63
#8	5/8	INDENTED HEX	2-1839	.70
#10	5/8	INDENTED HEX	2-1891	.74
#14	3/4	HEX - 7/16 HEAD	2-1867	1.15
5/16	3/4	INDENTED HEX WASHER	2-1963	1.64
5/16	1	INDENTED HEX	2-1890	1.64
#10	1/2	HEX WASHER - AB	2-1946	.91
#10	3/4	HEX WASHER - AB	2-1945	.93
#14	5/8	HEX WASHER - AB	2-1845	1.39
#14	3/4	HEX WASHER - AB	2-1936	1.45
#8	1/2	PHIL OVAL JACKSON	2-1872	.74
#8	3/4	PHIL OVAL JACKSON	2-1865	.76
#8	1	PHIL OVAL JACKSON	2-1866	.79
#8	1 1/4	PHIL OVAL JACKSON	2-1968	.84
#10	5/8	PHIL OVAL JACKSON	2-1880	.89
#10	3/4	PHIL OVAL JACKSON	2-1884	.91
#10	1	PHIL OVAL JACKSON	2-1885	.94
#6	3/8	PHILLIPS PAN	2-1846	.64
#8	3/8	PHILLIPS PAN	2-1879	.66
#8	1/2	PHILLIPS PAN	2-1868	.67
#8	5/8	PHILLIPS PAN	2-1882	.68
#8	3/4	PHILLIPS PAN	2-1869	.69
#8	1	PHILLIPS PAN	2-1870	.70
#10	5/8	PHILLIPS PAN	2-1871	.67
#10	1	PHILLIPS PAN	2-1940	.74
#14	5/8	PHILLIPS PAN	2-1892	.73
#10	1/2	PHILLIPS ROUND	2-1847	.68
#8	1/2	PHIL ROUND WASHER	2-1888	.69
#8	3/8	PHILLIPS TRUSS	2-1900	.63
#8	1/2	PHILLIPS TRUSS	2-1873	.64
#8	1	PHILLIPS TRUSS	2-1877	.67
#10	1/2	PHILLIPS TRUSS	2-1878	.68
#10	3/4	PHILLIPS TRUSS	2-1881	.69
#8	3/8	PHIL TRUSS JACKSON	2-1898	.68
#8	1/2	PHIL TRUSS JACKSON	2-1899	.70



# US INDENTED HEX CAP SCREWS

- ORIGINAL STYLE FASTENERS IN STAINLESS! - USED ON CARS AND TRUCKS FROM 1950-1980 -

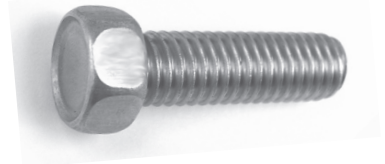
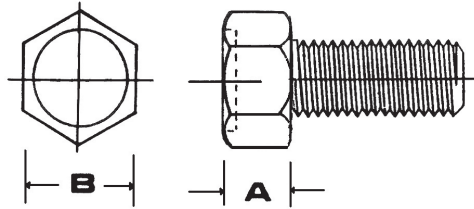

**DIMENSION TABLE (INCHES)**

D	DIAMETER	1/4	1/4	5/16	5/16	3/8	3/8
B	WRENCH	3/8	7/16	1/2	1/2	9/16	9/16
	THREADS/INCH	20	20	18	24	16	24

**PART NUMBER AND PRICE GUIDE**

SIZE:	1/4-20		1/4-20		5/16-18		5/16-24		3/8-16		3/8-24	
	3/8 WRENCH		7/16 WRENCH									
LENGTH	PART#	\$	PART#	\$	PART#	\$	PART#	\$	PART#	\$	PART#	\$
1/2	2-0230	2.50	2-0235	2.60			2-0993	2.70				
5/8	2-0231	2.55	2-0236	2.65	2-0090	2.70	2-0994	2.75				
3/4	2-0232	2.60	2-0237	2.70	2-0091	2.75	2-0995	2.80	2-0096	2.85	2-0978	2.90
7/8	2-0239	2.65	2-0238	2.75								
1	2-0233	2.80			2-0092	3.00	2-0996	3.10	2-0097	3.15	2-0998	3.20
1 1/4	2-0234	2.85			2-0099	3.10	2-0997	3.15	2-0098	3.20	2-0999	3.25
1 1/2					2-0980	3.15			2-0093	3.25		
1 3/4					2-0981	3.25			2-0969	3.30		
2					2-0982	3.35			2-0072	3.35		

# US INDENTED HEX WASHER HEAD SCREWS

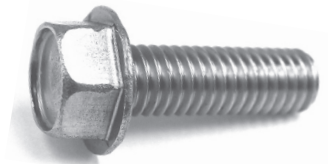
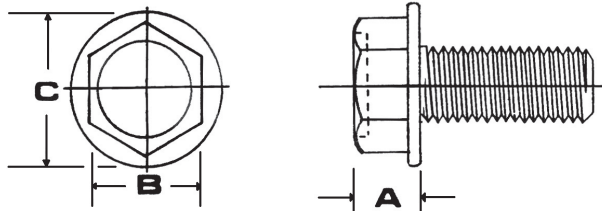

D	DIAMETER	1/4	5/16	5/16	5/16	3/8
C	FLANGE	.50	.64	.813	.813	.781
B	WRENCH	3/8	1/2	1/2	1/2	9/16
	THREADS/INCH	20	18	18	24	16

**PART NUMBER AND PRICE GUIDE**

SIZE:	10-24		1/4-20		5/16-18		5/16-18		5/16-24		3/8-16	
					11/16 FLANGE		13/16 FLANGE		13/16 FLANGE			
LENGTH	PART#	\$	PART#	\$	PART#	\$	PART#	\$	PART#	\$	PART#	\$
3/8	2-0961	2.65										
1/2	2-0962	2.70	2-0971	2.90	2-0080	3.05						
5/8	2-0963	2.75	2-0972	2.95	2-0081	3.10						
3/4	2-0964	2.80	2-0973	3.00	2-0082	3.15	2-0991	3.50	2-0992	3.55	2-0984	3.65
7/8			2-0974	3.10								
1			2-0975	3.15	2-0083	3.20					2-0985	3.75
1 1/4			2-0976	3.20	2-0989	3.25					2-0986	3.80
1 1/2			2-0977	3.25	2-0983	3.30					2-0987	3.85

# SOCKET HEAD CAP SCREWS

US COARSE THREAD - LOW STRENGTH -

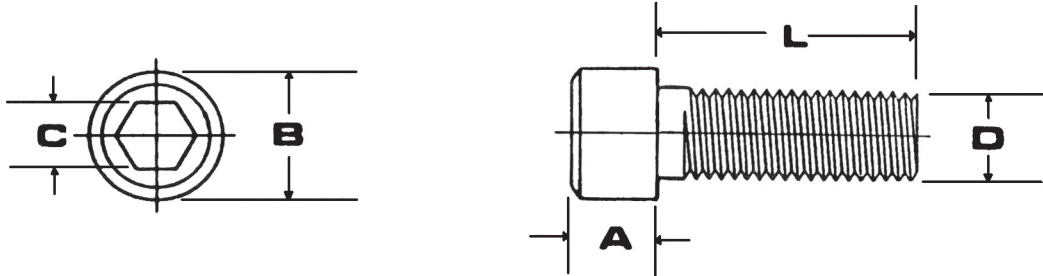

**DIMENSION TABLE (INCHES)**

D	DIAMETER	1/4	5/16	3/8	7/16	1/2	5/8
A	HEAD HT.	.250	.312	.375	.437	.50	.625
B	HEAD DIA.	.375	.469	.563	.656	.75	.934
C	KEY SIZE	3/16	1/4	5/16	3/8	3/8	1/2
THREADS/INCH		20	18	16	14	13	11



## PART NUMBER AND PRICE GUIDE

**\*\* SPECIFY APPLICATION ON ALL 7/16" AND LARGER SIZES \*\***

SIZE:	1/4-20		5/16-18		3/8-16		7/16-14**		1/2-13**		5/8-11**	
LENGTH	PART#	\$	PART#	\$	PART#	\$	PART#	\$	PART#	\$	PART#	\$
5/16			2-9972	.49								
3/8	2-0300	.23	2-0319	.43								
1/2	2-0301	.29	2-0320	.45	2-0339	.64						
5/8	2-0302	.32	2-0321	.46	2-0340	.69						
3/4	2-0303	.34	2-0322	.48	2-0341	.75	2-0360	1.65	2-0374	1.68		
7/8	2-0304	.36	2-0323	.49	2-0342	.79						
1	2-0305	.39	2-0324	.54	2-0343	.86	2-0361	1.86	2-0376	1.79	2-0394	3.60
1 1/4	2-0306	.44	2-0325	.59	2-0344	.94	2-0362	1.99	2-0377	1.88	2-0395	3.80
1 1/2	2-0307	.49	2-0326	.69	2-0345	.99	2-0363	2.22	2-0378	2.04	2-0396	3.95
1 3/4	2-0308	.54	2-0327	.79	2-0346	1.05	2-0364	2.95	2-0379	2.18	2-0397	4.30
2	2-0309	.59	2-0328	.89	2-0347	1.19	2-0365	3.40	2-0380	2.25	2-0398	4.50
2 1/4	2-0310	.63	2-0329	.98	2-0348	1.29	2-0387	3.95	2-0381	2.55	2-0399	4.70
2 1/2	2-0311	.70	2-0330	1.09	2-0349	1.49	2-0367	4.50	2-0382	2.60	2-0400	4.90
2 3/4	2-0312	.77	2-0331	1.19	2-0350	1.60			2-0383	2.90		
3	2-0313	.85	2-0332	1.28	2-0351	1.90	2-0369	5.39	2-0384	3.32	2-0402	5.40
3 1/4	2-0401	.99	2-0333	1.67	2-0352	2.46						
3 1/2	2-0315	.99	2-0334	2.03	2-0353	2.49	2-0370	5.78	2-0386	4.99	2-0404	7.96
3 3/4			2-0335	2.81	2-0354	3.57						
4	2-0317	1.56	2-0336	3.55	2-0355	3.96	2-0371	7.99	2-0389	5.68	2-0406	9.87
4 1/2	2-0372	3.00	2-0337	3.90	2-0356	4.98			2-0390	6.83		
5	2-0373	3.95	2-0338	4.30	2-0357	5.40			2-0391	7.40	2-0408	11.86
5 1/2			2-3391	4.80	2-3393	5.90			2-0392	8.60		
6			2-0375	6.00	2-0358	6.80			2-0393	9.99	2-0410	19.98
7 1/2									2-0388	11.60		

ADDITIONAL SIZES: 3/4-10 X 3 1/2 SOCKET # 2-0314 \$ 9.60

SOCKET HEAD COARSE THREAD SHOP ASSORTMENT: 635 PIECES # 3-3004 \$ 420.75

PERSONAL ASSORTMENT: 500 PIECES 3-3153 161.50



TOLL FREE ORDER LINE : 1-800-767-4781

# SOCKET HEAD CAP SCREWS

- SMALL SIZES & FINE THREAD - LOW STRENGTH -  
DIMENSION TABLE (INCHES)

D	DIAMETER	.112	.125	.138	.164	.190	.190	1/4	5/16	3/8	7/16	1/2
A	HEAD HT.	.112	.125	.138	.164	.190	.190	.156	.203	.234	.281	.313
B	HEAD DIA.	.183	.20	.226	.270	.312	.312	.375	.469	.563	.656	.75
C	KEY SIZE	3/32	3/32	7/64	9/64	5/32	5/32	3/16	1/4	5/16	3/8	3/8
ISO #		4	5	6	8	10	10					
THREADS/INCH		40	40	32	32	24	32	28	24	24	20	20

## PART NUMBER AND PRICE GUIDE - SMALL SIZES

ISO#	4-40		5-40		6-32		8-32		10-24		10-32	
LENGTH	PART#	\$	PART#	\$	PART#	\$	PART#	\$	PART#	\$	PART#	\$
1/4	2-0900	.07			2-0910	.08	2-0920	.09	2-9970	.25	2-9971	.25
5/16	2-0901	.08			2-0911	.09	2-0921	.11				
3/8	2-0902	.09			2-0912	.10	2-0922	.12	2-0932	.14	2-0944	.14
1/2	2-0903	.10	2-0967	.12	2-0913	.11	2-0923	.13	2-0933	.15	2-0945	.15
5/8	2-0904	.11			2-0914	.12	2-0924	.14	2-0934	.16	2-0946	.16
3/4	2-0905	.12			2-0915	.20	2-0925	.23	2-0935	.24	2-0947	.24
7/8	2-0906	.16			2-0916	.24	2-0926	.25	2-0936	.26	2-0948	.26
1	2-0907	.18			2-0917	.26	2-0927	.27	2-0937	.27	2-0949	.27
1 1/4	2-0908	.23			2-0918	.29	2-0928	.31	2-0938	.31	2-0950	.31
1 1/2	2-0909	.26			2-0919	.35	2-0929	.36	2-0939	.36	2-0951	.36
1 3/4	2-0966	.29			2-0943	.38	2-0930	.49	2-0940	.52	2-0952	.54
2							2-0931	.56	2-0941	.58	2-0953	.62
2 1/4												
2 1/2									2-0942	.76	2-0954	.78
3									2-0965	1.55		



## PART NUMBER AND PRICE GUIDE - FINE THREAD

\*\* SPECIFY APPLICATION ON ALL 7/16" AND LARGER SIZES \*\*

SIZE	1/4-28		5/16-24		3/8-24		7/16-20**		1/2-20**	
LENGTH	PART#	\$	PART#	\$	PART#	\$	PART#	\$	PART#	\$
3/8	2-0411	.24								
1/2	2-0412	.29	2-0427	.49	2-0440	.99				
5/8	2-0413	.33	2-0428	.47	2-0441	1.98				
3/4	2-0414	.35	2-0429	.49	2-0442	.74			2-9973	2.49
7/8	2-0415	.37	2-0430	.58						
1	2-0416	.39	2-0431	.63	2-0444	.86	2-0456	3.55	2-0467	1.99
1 1/4	2-0417	.48	2-0432	.64	2-0445	.95	2-0457	4.27	2-0468	2.41
1 1/2	2-0418	.55	2-0433	.74	2-0446	.98	2-0458	4.56	2-0469	2.69
1 3/4	2-0419	.59	2-0434	.87	2-0447	1.40	2-0459	4.82	2-0470	2.85
2	2-0420	.69	2-0435	.91	2-0448	1.45	2-0460	4.98	2-0471	2.99
2 1/4	2-0421	.74	2-0436	1.14	2-0449	1.49				
2 1/2	2-0422	1.19	2-0437	1.21	2-0450	1.96			2-0473	4.33
2 3/4			2-0438	1.35	2-0451	2.35				
3	2-0424	1.28	2-0439	1.49	2-0452	2.59			2-0475	6.47
3 1/2			2-0454	3.95						
4					2-0455	4.90			2-0405	17.15

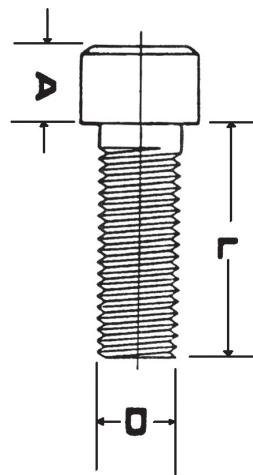

ADDITIONAL SIZES: 5-40 X 1/2 2-0967 .12 12-24 X 1 1/4 # 2-0990 \$ 1.79

\* 5/8-18 X 2 #2-0316 \$ 10.71 \*3/4-16 X 1 1/2 # 2-0385 \$ 7.90

SOCKET HEAD FINE THREAD SHOP ASSORTMENT: 635 PIECES # 3-3019 \$ 347.50  
PERSONAL ASSORTMENT: 400 PIECES 3-3156 164.00

# BINDING HEAD MACHINE SCREWS

- SLOTTED HEAD -

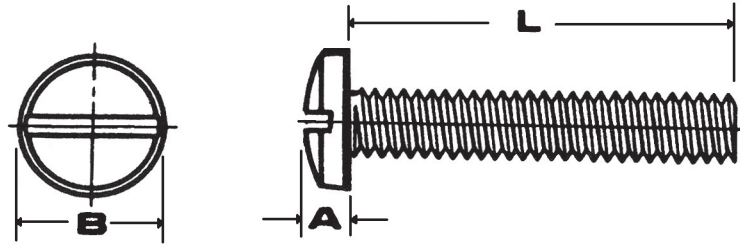

**DIMENSION TABLE (INCHES)**

D	DIAMETER	.112	.138	.164	.190	.190	.212	1/4
B	HEAD DIA.	.235	.29	.344	.399	.399	.454	.513
A	HEAD HT.	.063	.080	.097	.112	.112	.130	.153
	ISO #	4	6	8	10	10	12	
	THREADS/INCH	40	32	32	24	32	24	20

**PART NUMBER AND PRICE GUIDE**

SIZE:	4-40		6-32		8-32		10-24		10-32		12-24		1/4-20	
LENGTH	PART#	\$	PART#	\$	PART#	\$	PART#	\$	PART#	\$	PART#	\$	PART#	\$
1/8	2-2000	.08	2-2013	.11										
3/16	2-2001	.07	2-2014	.08										
1/4	2-2002	.07	2-2015	.08	2-2029	.09	2-2042	.09	2-2055	.11				
5/16			2-2016	.08	2-2030	.09								
3/8	2-2004	.08	2-2017	.09	2-2031	.09	2-2044	.10	2-2057	.13				
7/16			2-2018	.09										
1/2	2-2006	.08	2-2019	.09	2-2033	.10	2-2046	.15	2-2059	.15			2-2077	.34
5/8	2-2007	.09	2-2020	.10	2-2034	.11	2-2047	.16	2-2060	.16	2-2070	.32	2-2078	.39
3/4	2-2008	.09	2-2021	.12	2-2035	.14	2-2048	.19	2-2061	.19	2-2071	.36	2-2079	.43
7/8			2-2022	.13										
1	2-2010	.10	2-2023	.16	2-2037	.17	2-2050	.24	2-2063	.24	2-2072	.43	2-2081	.49
1 1/4			2-2024	.20	2-2038	.21	2-2051	.29	2-2064	.29			2-2082	.57
1 1/2			2-2025	.28	2-2039	.29	2-2052	.38	2-2065	.38			2-2083	.65
2			2-2027	.34	2-2041	.45	2-2054	.58	2-2067	.58			2-2085	.98

ADDITIONAL SIZES: 3-48 X 1/4 SLOTTED BINDING # 2-2012 \$ .19

1/4-20 X 5/8 PHILLIPS BINDING # 2-2090 \$ 0.26

**TOLL FREE ORDER LINE : 1-800-767-4781**

# FILLISTER HEAD MACHINE SCREWS

- PHILLIPS HEAD -

SIZE:	6-32		8-32		10-24		10-32		1/4-20	
LENGTH	PART#	\$	PART#	\$	PART#	\$	PART#	\$		
3/8	2-6111	.14	2-6127	.16			2-6151	.20		
1/2	2-6112	.15	2-6128	.17			2-6152	.22	2-6164	.46
5/8			2-6129	.18						
3/4			2-6130	.19	2-6142	.25	2-6154	.25		
1			2-6132	.21			2-6156	.29		



# FILLISTER HEAD MACHINE SCREWS

- SLOTTED HEAD -

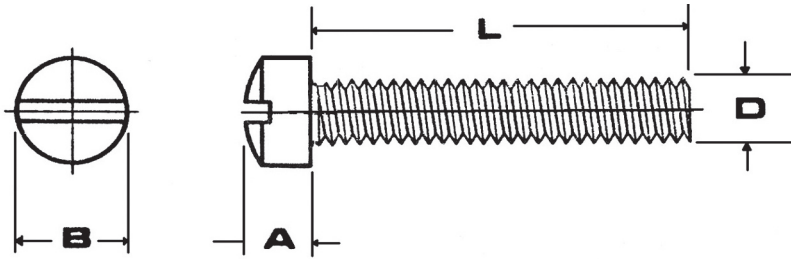

**DIMENSION TABLE (INCHES)**

D	DIAMETER	.112	.138	.164	.190	.190	.216	1/4	1/4	5/16	3/8
B	HEAD DIA.	.17	.21	.26	.30	.30	.34	.40	.40	.50	.60
A	HEAD HT.	.09	.11	.14	.17	.17	.19	.21	.21	.27	.33
ISO #		4	6	8	10	10	12				
THREADS/INCH		40	32	32	24	32	24	20	28	18	16

**PART NUMBER AND PRICE GUIDE**

SIZE:	4-40		6-32		8-32		10-24		10-32		12-24		1/4-20	
LENGTH	PART#	\$	PART#	\$	PART#	\$	PART#	\$	PART#	\$	PART#	\$	PART#	\$
1/8	2-2100	.07			2-2126	.26								
1/4	2-2102	.07	2-2113	.09	2-2127	.14	2-2140	.18	2-2153	.18				
5/16	2-2103	.07	2-2114	.09	2-2128	.15	2-2141	.19	2-2154	.19				
3/8	2-2104	.08	2-2115	.10	2-2129	.16	2-2142	.20	2-2155	.20	2-2177	.39	2-2179	.39
7/16	2-2105	.08							2-2156	.21				
1/2	2-2106	.08	2-2117	.10	2-2131	.17	2-2144	.21	2-2157	.20	2-2170	.44	2-2180	.45
5/8	2-2107	.09	2-2118	.10	2-2132	.18	2-2145	.22	2-2158	.22	2-2171	.49	2-2181	.49
3/4	2-2108	.10	2-2119	.13	2-2133	.18	2-2146	.23	2-2159	.23	2-2172	.54	2-2182	.53
7/8			2-2120	.16	2-2134	.19	2-2147	.28	2-2160	.28				
1	2-2110	.13	2-2121	.19	2-2135	.22	2-2148	.29	2-2161	.29	2-2173	.59	2-2184	.57
1 1/8					2-2126	.26								
1 1/4			2-2122	.24	2-2136	.28	2-2149	.38	2-2162	.38			2-2185	.61
1 1/2			2-2123	.26	2-2137	.32	2-2150	.46	2-2163	.46			2-2186	.67
1 3/4					2-2138	.38	2-2151	.57	2-2164	.54			2-2187	.73
2			2-2125	.29	2-2139	.53	2-2152	.69	2-2165	.69			2-2188	.79
2 1/2					2-2190	.98			2-2166	.76			2-2176	.97
3									2-2167	.99				

SIZE:	1/4-28		5/16-18		3/8-16	
LENGTH	PART#	\$	PART#	\$	PART#	\$
1/2	2-2169	.46	2-2101	.49		
5/8	2-2191	.49				
3/4	2-2192	.54	2-2194	.89	2-2196	.99
1	2-2193	.59	2-2195	.94	2-6170	1.19
1 1/4			2-2189	.98		
1 1/2			2-2109	.99	2-2143	1.29
1 3/4			2-2111	.99		
2			2-2112	1.10	2-2168	1.48
2 1/2			2-2124	1.19		
3			2-2130	1.28		

SLOTTED FILLISTER MACHINE SCREW SHOP ASSORTMENT: 1720 PIECES # 3-3055 \$ 302.50  
 PERSONAL ASSORTMENT: 850 PIECES 3-3157 148.00

# FLAT HEAD MACHINE SCREWS

- PHILLIPS HEAD -

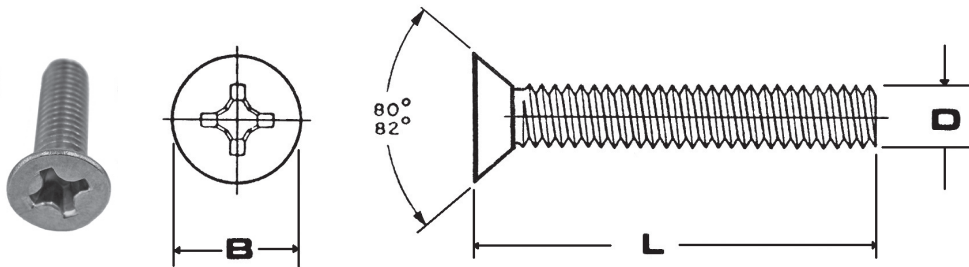

DIMENSION TABLE (INCHES)

D	DIAMETER	.112	.138	.164	.190	.190	.216	1/4	1/4	5/16	3/8
B	HEAD DIA.	.21	.26	.30	.37	.37	.40	.46	.46	.59	.70
ISO #		4	6	8	10	10	12				
THREADS/INCH		40	32	32	24	32	24	20	28	18	16

PART NUMBER AND PRICE GUIDE

SIZE:	4-40		6-32		8-32		10-24		10-32	
LENGTH	PART#	\$	PART#	\$	PART#	\$	PART#	\$	PART#	\$
3/16					2-2438	.04				
1/4	2-2345	.02	2-2350	.03	2-2362	.05	2-2434	.05	2-2368	.06
5/16	2-2340	.02	2-2351	.03	2-2374	.05				
3/8	2-2341	.03	2-2352	.03	2-2364	.05	2-2375	.06	2-2386	.06
1/2	2-2342	.03	2-2353	.04	2-2365	.05	2-2376	.07	2-2387	.08
5/8	2-2343	.04	2-2354	.05	2-2366	.06	2-2377	.08	2-2388	.08
3/4	2-2344	.04	2-2355	.05	2-2367	.07	2-2378	.11	2-2389	.09
7/8			2-2356	.05	2-2316	.08	2-2379	.12	2-2390	.11
1	2-2346	.05	2-2357	.06	2-2369	.08	2-2380	.12	2-2391	.12
1 1/4	2-2347	.06	2-2358	.06	2-2370	.10	2-2381	.14	2-2392	.14
1 1/2			2-2359	.10	2-2371	.11	2-2382	.15	2-2393	.15
1 3/4					2-2372	.13	2-2437	.19	2-2439	.19
2			2-2361	.13	2-2373	.14	2-2384	.26	2-2395	.24
2 1/2							2-2383	.34	2-2394	.38
3							2-2385	.40	2-2407	.45

**PHILLIPS FLAT JACKSON HEAD**

- 5/16-24 X 1 # 2-2435 \$.89
- X 1 1/4 2-2432 .95
- X 1 1/2 2-2433 .99



**PHILLIPS FLAT MACHINE SCREW SHOP ASSORTMENT: 1720 PIECES**

- # 3-3027 \$ 211.00
- PERSONAL ASSORTMENT:
- 850 PIECES 3-3158 130.00

PART NUMBER AND PRICE GUIDE

SIZE:	12-24		1/4-20		1/4-28		5/16-18		5/16-24		3/8-16	
LENGTH	PART#	\$	PART#	\$	PART#	\$	PART#	\$	PART#	\$	PART#	\$
3/8			2-2473	.16								
1/2	2-2396	.16	2-2397	.17	2-2422	.19	2-2416	.29				
5/8	2-2442	.17	2-2398	.18			2-2425	.32				
3/4	2-2360	.18	2-2399	.20	2-2420	.24	2-2410	.35	2-2441	.84		
7/8			2-2400	.21	2-2447	.28					2-2484	.49
1	2-2443	.23	2-2401	.22	2-2408	.39	2-2412	.39			2-2348	.51
1 1/4	2-2444	.24	2-2402	.25	2-2421	.58	2-2413	.48				
1 1/2	2-2445	.35	2-2403	.29	2-2431	.59	2-2414	.56			2-2427	.74
1 3/4	2-2446	.39	2-2404	.32			2-2415	.69			2-2448	.89
2			2-2405	.34	2-2426	.65	2-2417	1.00			2-2449	1.12
2 1/2			2-2409	.35			2-2418	1.18			2-2454	1.29
3			2-2406	.45			2-2419	1.29				
3 1/2			2-2423	.49								
4			2-2411	.54							2-2429	1.44
5			2-6180	.99			2-2488	2.89				

# FLAT HEAD MACHINE SCREWS

## - SLOTTED HEAD - DIMENSION TABLE (INCHES)

D	DIAMETER	.086	.112	.138	.164	.190	.190	.216	1/4	1/4	5/16	5/16	3/8	1/2
B	HEAD DIA.	.155	.21	.26	.30	.37	.37	.40	.46	.46	.59	.59	.70	.81
	ISO #	2	4	6	8	10	10	12						
	THREADS/INCH	56	40	32	32	24	32	24	20	28	18	24	16	13

### PART NUMBER AND PRICE GUIDE

SIZE:	2-56		4-40		6-32		8-32		10-24		10-32		12-24	
LENGTH	PART#	\$	PART#	\$	PART#	\$	PART#	\$	PART#	\$	PART#	\$	PART#	\$
3/16	2-2247	.04	2-2200	.04	2-2212	.05								
1/4			2-2201	.04	2-2213	.05	2-2226	.09	2-2240	.11	2-2255	.11		
5/16			2-2202	.04	2-2214	.07	2-2227	.09			2-2256	.12		
3/8			2-2203	.04	2-2215	.07	2-2228	.09	2-2242	.13	2-2257	.13	2-2270	.24
7/16			2-2204	.05	2-2216	.08	2-2229	.09	2-2243	.15	2-2258	.15		
1/2			2-2205	.05	2-2217	.08	2-2230	.10	2-2244	.17	2-2259	.17	2-2271	.25
5/8			2-2206	.06	2-2218	.08	2-2231	.12	2-2245	.18	2-2260	.18	2-2272	.27
3/4			2-2207	.06	2-2219	.09	2-2232	.13	2-2246	.19	2-2261	.19	2-2273	.29
7/8			2-2208	.07	2-2220	.10	2-2233	.14	2-2224	.20	2-2262	.20		
1			2-2209	.08	2-2221	.10	2-2234	.15	2-2248	.21	2-2263	.21	2-2275	.32
1 1/4			2-2210	.09	2-2222	.12	2-2235	.17	2-2249	.23	2-2264	.23	2-2276	.34
1 1/2					2-2223	.13	2-2236	.19	2-2250	.25	2-2265	.25	2-2277	.38
1 3/4							2-2237	.21	2-2251	.27	2-2266	.27		
2					2-2225	.16	2-2239	.24	2-2252	.29	2-2267	.29	2-2279	.48
2 1/2							2-2238	.28	2-2253	.35	2-2268	.35	2-2278	.59
3							2-2241	.37	2-2254	.42	2-2269	.42		

### PART NUMBER AND PRICE GUIDE

SIZE:	1/4-20		1/4-28		5/16-18		5/16-24		3/8-16		1/2-13	
LENGTH	PART#	\$	PART#	\$	PART#	\$	PART#	\$	PART#	\$	PART#	\$
3/8	2-2280	.19	2-2294	.24								
1/2	2-2281	.21	2-2295	.27	2-2302	.29						
5/8	2-2282	.23	2-2430	.29	2-2303	.33						
3/4	2-2283	.25	2-2297	.32	2-2304	.36	2-2298	.92	2-2317	.49	2-2329	1.69
7/8	2-2284	.27			2-2305	.99						
1	2-2285	.29	2-2299	.33	2-2306	.42	2-2330	.93	2-2319	.57	2-2331	1.79
1 1/4	2-2286	.31	2-2318	.37	2-2307	.46			2-2320	.62	2-2332	1.86
1 1/2	2-2287	.33	2-2337	.39	2-2308	.49			2-2321	.67	2-2333	1.94
1 3/4	2-2288	.35			2-2309	.54			2-2322	.74		
2	2-2289	.41			2-2310	.58	2-2428	.99	2-2323	.84		
2 1/4	2-6300	.43			2-6302	.89						
2 1/2	2-2290	.45			2-2311	.69			2-2324	.97		
2 3/4	2-6301	.47										
3	2-2291	.51			2-2312	.79			2-2325	1.29		
3 1/2	2-2292	.86			2-2313	1.29			2-2326	1.78	2-2338	2.39
4	2-2293	.98			2-2314	1.47			2-2327	1.97		
6									2-2328	6.65		



SLOTTED FLAT JACKSON HEADS ; .40" O.D. HEAD - 1/4-20 X 1 #2-2301 \$ 2.40  
 .42" O.D. HEAD - 1/4-20 X 3/4 2-2436 2.25  
 5-16-24 X 2 2-2440 2.99  
 5/16-24 X 3/4 2-2339 3.14  
 5/16-24 X 1" 2-2335 3.17  
 .47" O.D. HEAD - 5/16-18 X 7/8 2-2300 3.40  
 5/16-24 X 1" 2-2335 3.75

SLOTTED FLAT MACHINE SCREW ASSORTMENT: 1720 PIECES # 3-3028 \$ 310.75  
 PERSONAL ASSORTMENT: 850 PIECES 3-3171 153.00

# OVAL MACHINE SCREWS

- PHILLIPS HEAD -

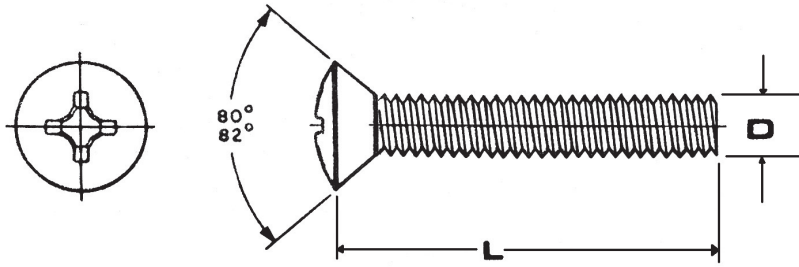

**DIMENSION TABLE (INCHES)**

D	DIAMETER	.112	.138	.164	.190	.190	.216	1/4	1/4	5/16	5/16
B	HEAD DIA.	.23	.28	.33	.39	.39	.44	.48	.48	.60	.60
	ISO #	4	6	8	10	10	12				
	THREADS/INCH	40	32	32	24	32	24	20	28	18	24

**PART NUMBER AND PRICE GUIDE**

SIZE:	4-40		6-32		8-32		10-24		10-32		12-24		1/4-20		1/4-28	
LENGTH	PART#	\$	PART#	\$	PART#	\$	PART#	\$	PART#	\$	PART#	\$	PART#	\$	PART#	\$
1/4	2-3290	.04	2-3232	.05	2-3251	.07	2-3238	.08	2-7523	.08						
5/16									2-7551	.09						
3/8	2-3295	.04	2-3200	.06	2-3207	.07	2-3215	.09	2-3223	.09			2-7533	.18	2-3249	.43
1/2	2-3292	.04	2-3201	.07	2-3208	.08	2-3216	.10	2-3224	.10	2-3239	.17	2-3231	.19	2-3250	.45
5/8			2-3202	.08	2-3209	.09	2-3217	.12	2-3225	.12	2-7526	.19	2-3242	.23	2-3252	.47
3/4	2-3293	.05	2-3203	.09	2-3210	.10	2-3218	.13	2-3226	.13	2-7527	.20	2-3233	.25	2-3260	.49
7/8					2-7521	.11	2-7522	.14	2-7524	.14			2-3257	.27		
1	2-3294	.06	2-3204	.11	2-3211	.12	2-3219	.15	2-3227	.15	2-3240	.28	2-3234	.36	2-3261	.52
1 1/4	2-7550	.14	2-3205	.12	2-3212	.14	2-3220	.16	2-3228	.16	2-7529	.32	2-3235	.38		
1 1/2			2-3206	.13	2-3213	.17	2-3221	.19	2-3229	.19	2-3264	.56	2-3236	.40		
1 3/4									2-7525	.21			2-7534	.42		
2			2-3124	.16	2-3214	.21	2-3222	.22	2-3230	.23			2-3237	.44		
2 1/2					2-3273	.29	2-3244	.39	2-3246	.40			2-3248	.46		
3							2-3245	.45	2-3247	.46	2-7532	.65	2-3241	.49		
3 1/2													2-7535	.52		
4													2-3259	.56		

**PART NUMBER AND PRICE GUIDE**

SIZE:	5/16-18		5/16-24	
LENGTH	PART#	\$	PART#	\$
1/2				
5/8				
3/4	2-3275	.39	2-3280	.95
1	2-3258	.48	2-3281	.99
1 1/4	2-7536	.59	2-3282	1.05
1 1/2	2-3253	.63	2-3283	1.10
1 3/4	2-7537	.69		
2	2-3254	.74		
2 1/2	2-3255	.98		
3	2-7538	1.19		

**PART NUMBER AND PRICE GUIDE: JACKSON HEAD**

SIZE:	8-32		10-32		1/4-20		1/4-20		5/16-18	
HEAD SIZE:	#6 HEAD		#8 HEAD		#10 HEAD		#12 HEAD		1/4 HEAD	
LENGTH	PART#	\$	PART#	\$	PART#	\$	PART#	\$	PART#	\$
3/8	2-3276	.19								
1/2	2-3277	.22	2-3284	.29	2-3243	.43				
5/8	2-3278	.24	2-3285	.30	2-3338	.44	2-3272	.55		
3/4	2-3289	.26	2-3286	.31	2-3270	.45	2-3344	.93	2-3336	1.99
7/8			2-3334	.32	2-3265	.49	2-3269	.59		
1	2-3279	.29	2-3287	.33			2-3291	.96	2-3268	.79
1 1/4			2-3288	.35			2-3274	.98	2-3266	.89
1 1/2									2-3267	.99

**ADDITIONAL SIZES:**

3/8-16 X 1	# 2-7540	\$ .89
1 1/4	2-7541	.98
3	2-7549	1.97

NEW SIZE: 10-24 X 3/4 PHILLIPS OVAL JACKSON HEAD (#8 HEAD) # 2-3263 \$ .78  
 1/4-28 X 5/8 PHILLIPS OVAL JACKSON HEAD (#12 HEAD) 2-3262 1.38

PHILLIPS OVAL MACHINE SCREW SHOP ASSORTMENT: 1720 PIECES # 3-3029 \$ 261.75

PERSONAL ASSORTMENT: 850 PIECES 3-3166 118.90



# OVAL MACHINE SCREWS

- SLOTTED HEAD -

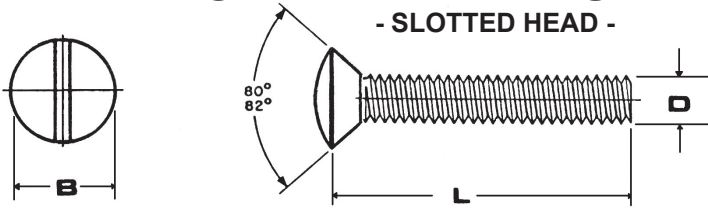

DIMENSION TABLE (INCHES)

D	DIAMETER	.112	.138	.164	.190	.190	.216	1/4	1/4	5/16	5/16	3/8	7/16
B	HEAD DIA.	.23	.28	.33	.39	.39	.44	.48	.48	.60	.60	.72	.75
ISO #		4	6	8	10	10	12						
THREADS/INCH		40	32	32	24	32	24	20	28	18	24	16	20



## PART NUMBER AND PRICE GUIDE

ISO #	4-40		5-40		6-32		8-32		10-24		10-32		12-24	
LENGTH	PART#	\$			PART#	\$	PART#	\$	PART#	\$	PART#	\$	PART#	\$
1/4	2-3109	.04			2-3169	.05	2-3128	.08	2-2501	.19	2-3156	.19		
5/16	2-3110	.04			2-3118	.05								
3/8	2-3111	.04	2-3117	.09	2-3120	.06	2-3129	.09	2-3138	.21	2-3147	.21		
1/2	2-3112	.05			2-3121	.06	2-3130	.10	2-3139	.22	2-3148	.22	2-3170	.36
5/8	2-3113	.05			2-3122	.07	2-3131	.11	2-3140	.23	2-3149	.23		
3/4	2-3114	.05			2-3123	.07	2-3132	.12	2-3141	.24	2-3150	.24	2-3166	.39
7/8					2-7501	.08	2-7502	.13	2-7503	.25	2-3151	.25		
1	2-3179	.07			2-3125	.09	2-3134	.13	2-3143	.26	2-3152	.26	2-3167	.41
1 1/4	2-7500	.09			2-7519	.10	2-3135	.14	2-3144	.27	2-3153	.27	2-7505	.45
1 1/2					2-3127	.11	2-3136	.15	2-3145	.28	2-3154	.28	2-3171	.49
1 3/4							2-5362	.19	2-5363	.31	2-5364	.31		
2					2-3168	.13	2-3299	.21	2-3146	.34	2-3155	.34	2-3175	.58
2 1/2							2-5356	.28	2-5358	.39	2-5360	.99		
3							2-5357	.37	2-5359	.48	2-5361	.48		

## PART NUMBER AND PRICE GUIDE

SIZE:	1/4-20		1/4-28		5/16-18		5/16-24		3/8-16	
LENGTH	PART#	\$	PART#	\$	PART#	\$	PART#	\$	PART#	\$
3/8	2-3160	.24								
1/2	2-3157	.26	2-3176	.34	2-7508	.54				
5/8	2-3158	.29	2-5321	.37						
3/4	2-3159	.31	2-3178	.39	2-3174	.59	2-3187	.79		
7/8	2-3183	.35								
1	2-3161	.38	2-3173	.44	2-3165	.67	2-3188	.89	2-3190	.79
1 1/4	2-3162	.44	2-5325	.49	2-5320	.69	2-3189	.98	2-7513	2.98
1 1/2	2-3163	.49			2-3115	.71			2-7514	2.98
1 3/4	2-7515	.58								
2	2-3164	.68			2-3298	.99			2-7510	2.98
2 1/2	2-7506	.76			2-7509	1.38	2-5336	12.90	2-7512	2.98
3	2-3119	.83			2-3133	1.79			2-7511	2.98
3 1/2	2-7507	.89								
4	2-3182	.98			2-2917	1.95				

**SPECIAL SIZE:**  
 8-32 X 1 TYPE A  
 #2-5393 \$1.49  
 \*FOR 1940  
 CHEVY  
 HEADLIGHT  
 RINGS\*

JACKSON (UNDERSIZED HEAD) SCREWS: 5/16-24 X 7/16 (# 12 HEAD) 2-5351 \$4.99 7/16-20 X 1 1/2 2-5333 \$ 13.60  
 SCREWS - USED ON ANTIQUE DOOR X 1/2 2-5350 4.99  
 HINGES - SEE PAGE 102 FOR FLAT SOCKETS X 5/8 2-5349 2.99\* 1/4-20 X 1/2 2-5330 2.40  
 WE CAN CUSTOM MAKE ANY SIZE X 3/4 2-5352 1.99\* X 5/8 2-5331 2.43  
 JACKSON HEAD SCREW - GIVE US A CALL X 1 2-5354 2.09\* X 3/4 2-5332 2.45  
 \* NOT FULLY THREADED TO HEAD\* X 1 1/4 2-5355 2.18\* X 1 2-5334 2.52

SLOTTED OVAL MACHINE SCREW SHOP ASSORTMENT: 1720 PIECES # 3-3030 \$ 380.50  
 PERSONAL ASSORTMENT: 850 PIECES 3-3172 157.00

# PAN MACHINE SCREWS

- PHILLIPS HEAD -

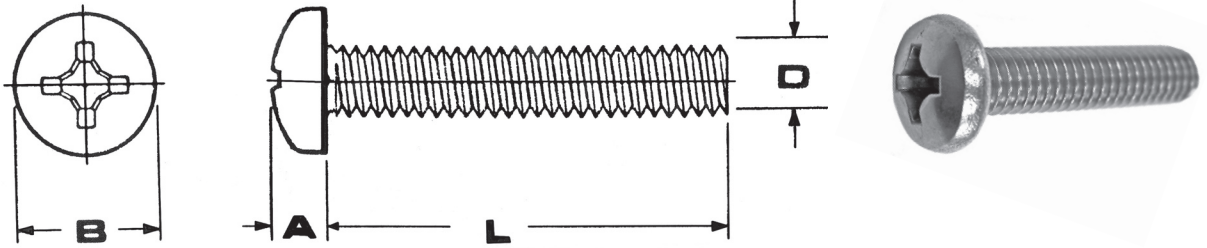

DIMENSION TABLE (INCHES)

D	DIAMETER	.112	.138	.164	.190	.190	.216	1/4	1/4	5/16	3/8
B	HEAD DIA.	.29	.27	.322	.373	.373	.416	.492	.492	.615	.74
A	HEAD HT.	.068	.082	.096	.11	.11	.119	.144	.144	.178	.212
ISO #		4	6	8	10	10	12				
THREADS/INCH		40	32	32	24	32	24	20	28	18	16

PART NUMBER AND PRICE GUIDE

SIZE:	4-40		6-32		8-32		10-24		10-32	
LENGTH	PART#	\$	PART#	\$	PART#	\$	PART#	\$	PART#	\$
1/4	2-2930	.03	2-2939	.05	2-2949	.05	2-2919	.07	2-2929	.07
5/16	2-2931	.04	2-2940	.04	2-2950	.06				
3/8	2-2932	.04	2-2941	.05	2-2951	.07	2-2962	.09	2-2973	.09
1/2	2-2933	.05	2-2942	.05	2-2952	.08	2-2963	.10	2-2974	.10
5/8	2-2934	.05	2-2943	.06	2-2953	.09	2-2964	.12	2-2975	.12
3/4	2-2935	.06	2-2944	.07	2-2954	.10	2-2965	.15	2-2976	.15
7/8			2-2903	.08	2-2960	.11	2-2875	.16	2-2970	.16
1	2-2936	.07	2-2945	.08	2-2956	.12	2-2966	.17	2-2977	.17
1 1/4	2-2927	.08	2-2946	.10	2-2957	.13	2-2967	.19	2-2978	.19
1 1/2	2-2928	.09	2-2947	.15	2-2958	.16	2-2968	.21	2-2979	.21
1 3/4			2-2905	.16	2-2909	.18	2-2898	.22	2-2874	.22
2			2-2971	.16	2-2959	.19	2-2969	.23	2-2980	.23
2 1/2			2-2972	.16	2-2913	.21	2-2982	.26	2-2992	.26
3							2-2983	.29	2-2993	.29

PART NUMBER AND PRICE GUIDE

SIZE:	12-24		1/4-20		1/4-28		5/16-18		3/8-16	
LENGTH	PART#	\$	PART#	\$	PART#	\$	PART#	\$	PART#	\$
3/8	2-2794	.17	2-2984	.19						
1/2	2-2711	.18	2-2985	.20	2-2925	.41	2-2995	.42		
5/8	2-2795	.21	2-2986	.22	2-2876	.43	2-2961	.60		
3/4	2-2722	.24	2-2987	.24	2-2938	.44	2-2955	.65		
7/8			2-2937	.25						
1	2-2796	.28	2-2988	.25	2-2877	.49	2-2996	.70	2-2948	.79
1 1/4			2-2989	.27	2-2878	.57	2-2870	.73		
1 1/2	2-2798	.36	2-2990	.31	2-2879	.69	2-2997	.75		
1 3/4	2-2799	.44	2-2872	.34						
2			2-2991	.37			2-2998	.82		
2 1/2			2-2981	.39			2-2999	1.18		
3			2-2994	.44			2-2880	1.39		
3 1/2			2-2873	.58						

PHILLIPS PAN MACHINE SCREW SHOP ASSORTMENT: 1720 PIECES # 3-3031 \$220.50  
 PERSONAL ASSORTMENT: 850 PIECES 3-3167 130.00

# PAN MACHINE SCREWS

- SLOTTED HEAD -

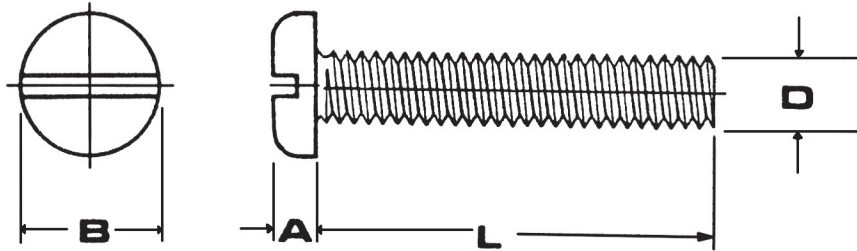

DIMENSION TABLE (INCHES)

D	DIAMETER	.112	.138	.164	.190	.190	.216	1/4	1/4	5/16	3/8
B	HEAD DIA.	.219	.27	.322	.373	.373	.416	.492	.492	.615	.74
A	HEAD HT.	.068	.082	.096	.11	.11	.119	.144	.144	.178	.212
	ISO #	4	6	8	10	10	12				
	THREADS/INCH	40	32	32	24	32	24	20	28	18	16

PART NUMBER AND PRICE GUIDE

SIZE:	4-40		6-32		8-32		10-24		10-32	
LENGTH	PART#	\$	PART#	\$	PART#	\$	PART#	\$	PART#	\$
1/4	2-2701	.04	2-2712	.06	2-2725	.09	2-2739	.09	2-2753	.09
5/16	2-2702	.04	2-2713	.06	2-2726	.08			2-2754	.10
3/8	2-2703	.04	2-2714	.06	2-2727	.08	2-2741	.10	2-2755	.11
1/2	2-2704	.05	2-2715	.07	2-2728	.08	2-2742	.11	2-2756	.13
5/8	2-2705	.05	2-2716	.07	2-2729	.09	2-2743	.12	2-2757	.14
3/4	2-2706	.06	2-2717	.08	2-2730	.10	2-2744	.13	2-2758	.15
7/8	2-2707	.06	2-2718	.08	2-2731	.11	2-2776	.15	2-2759	.16
1	2-2708	.07	2-2719	.09	2-2732	.12	2-2746	.16	2-2760	.17
1 1/4	2-2710	.09	2-2720	.10	2-2733	.13	2-2747	.18	2-2761	.19
1 1/2	2-2709	.11	2-2721	.13	2-2734	.15	2-2748	.19	2-2762	.21
1 3/4					2-2735	.17	2-2749	.24	2-2763	.24
2			2-2723	.13	2-2736	.19	2-2750	.29	2-2764	.29
2 1/2					2-2837	.24	2-2751	.39	2-2765	.39
3					2-2724	.38				



PART NUMBER AND PRICE GUIDE

SIZE:	12-24		1/4-20		1/4-28		5/16-18		3/8-16	
LENGTH	PART#	\$	PART#	\$	PART#	\$	PART#	\$	PART#	\$
3/8	2-2768	.29	2-2881	.29	2-2894	.54				
1/2	2-2769	.34	2-2882	.30	2-2895	.58	2-2906	.49	2-2918	.78
5/8	2-2770	.37	2-2883	.31	2-2896	.59	2-2907	.54		
3/4	2-2771	.39	2-2884	.32	2-2897	.62	2-2908	.59	2-2920	.88
7/8			2-2885	.36						
1	2-2773	.41	2-2886	.39	2-2899	.69	2-2910	.64	2-2922	.99
1 1/4			2-2887	.44	2-2900	.74	2-2911	.69		
1 1/2	2-2775	.49	2-2888	.46			2-2912	.79	2-2924	1.07
1 3/4			2-2893	.48						
2	2-2777	.54	2-2890	.49			2-2914	.99	2-2926	1.18
2 1/2			2-2891	.55			2-2915	1.18		
3			2-2892	.59			2-2916	1.37		

**UNSLOTTED PAN HEAD: 1/4-20 X 3/4 # 2-2902 \$ .29**

SLOTTED PAN MACHINE SCREW SHOP ASSORTMENT: 1720 PIECES # 3-3032 \$307.50  
 PERSONAL ASSORTMENT: 850 PIECES 3-3173 155.00

# ROUND MACHINE SCREWS

- PHILLIPS HEAD -

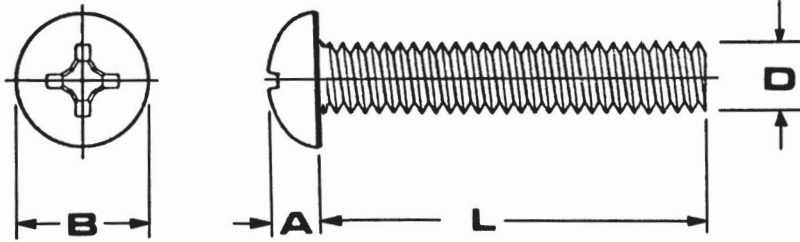

DIMENSION TABLE (INCHES)

D	DIAMETER	.112	.138	.164	.190	.190	1/4	5/16
B	HEAD DIA.	.211	.26	.309	.359	.359	.472	.59
A	HEAD HT.	.086	.103	.12	.137	.137	.175	.216
ISO #		4	6	8	10	10		
THREADS/INCH		40	32	32	24	32	20	18

PART NUMBER AND PRICE GUIDE

SIZE:	4-40		6-32		8-32		10-24		10-32		12-24	
LENGTH	PART#	\$	PART#	\$	PART#	\$	PART#	\$	PART#	\$	PART#	\$
3/16			2-2682	.05								
1/4	2-2630	.04	2-2636	.05	2-2645	.06	2-2654	.10	2-2664	.10		
3/8	2-2631	.04	2-2637	.05	2-2646	.07	2-2656	.11	2-2665	.11		
1/2	2-2632	.05	2-2638	.06	2-2647	.07	2-2657	.12	2-2666	.12	2-7803	.19
5/8	2-2633	.06	2-2639	.07	2-2648	.08	2-2658	.13	2-2667	.13	2-7804	.23
3/4	2-2634	.06	2-2640	.08	2-2649	.09	2-2659	.14	2-2668	.14	2-7805	.29
7/8			2-2615	.09	2-2618	.10	2-7815	.15	2-7800	.15		
1	2-2635	.07	2-2641	.09	2-2650	.10	2-2660	.16	2-2669	.16	2-2681	.32
1 1/4	2-2627	.09	2-2642	.11	2-2651	.12	2-2661	.17	2-2670	.19		
1 1/2	2-2628	.11	2-2643	.12	2-2652	.14	2-2662	.19	2-2671	.20		
2			2-2644	.14	2-2653	.19	2-2663	.22	2-2672	.24		
2 1/2							2-2683	.44	2-7816	.36		
3							2-2698	.49	2-2686	.49		
4												

ADDITIONAL SIZE:  
 3/8-16 X 3/4 2-7818 \$.60  
 3/8-16 X 1 1/4 2-2697 \$.83

SIZE:	1/4-20		1/4-28		5/16-18	
LENGTH	PART#	\$	PART#	\$	PART#	\$
3/8	2-2673	.15				
1/2	2-2674	.16	2-7807	.29	2-2690	.36
5/8	2-2675	.17	2-7808	.38	2-7812	.38
3/4	2-2676	.18	2-2689	.49	2-2691	.39
7/8						
1	2-2677	.20	2-7810	.58	2-2692	.45
1 1/4	2-2678	.24				
1 1/2	2-2679	.27	2-7811	.69	2-2693	.62
2	2-2680	.39			2-2694	.82
2 1/4	2-2687	.42			2-2695	1.00
2 1/2	2-7817	.38				
3	2-2688	.49				
4	2-7806	.99				

UNSLOTTED ROUND HEAD SCREWS:

- 4-40 x 3/8 # 2-2616 \$.28
- 4-40 x 3/4 2-2474 .29
- 6-32 x 5/8 2-2614 .34



DAD WITH MY COUSIN (NOW MY STEP BROTHER) AND HIS DAD ON OUR 1926 MACK CHAIN DRIVE FIRE TRUCK BACK IN 80'S.

PHILLIPS ROUND MACHINE SCREW SHOP ASSORTMENT: 1720 PIECES # 3-3033 \$ 202.50  
 PERSONAL ASSORTMENT: 850 PIECES 3-3174 130.00



# ROUND MACHINE SCREWS

- SLOTTED HEAD -

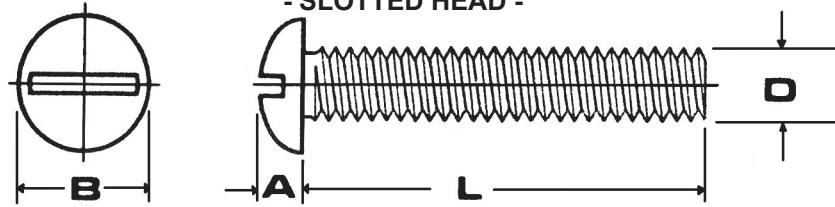

DIMENSION TABLE (INCHES)

D	DIAMETER	.086	.112	.138	.164	.190	.190	1/4	1/4	5/16	3/8	1/2
B	HEAD DIA.	.15	.211	.26	.309	.359	.359	.472	.472	.59	.62	.78
A	HEAD HT.	.07	.086	.103	.12	.137	.137	.175	.175	.216	.26	.37
ISO #		2	4	6	8	10	10					
THREADS/INCH		56	40	32	32	24	32	20	28	18	16	13

PART NUMBER AND PRICE GUIDE

SIZE:	2-56		4-40		6-32		8-32		10-24		10-32	
LENGTH	PART#	\$	PART#	\$	PART#	\$	PART#	\$	PART#	\$	PART#	\$
3/16			2-2450	.07	2-2462	.08	2-2476	.08				
1/4			2-2451	.07	2-2463	.08	2-2477	.10	2-2492	.14	2-2507	.14
5/16			2-2452	.07	2-2464	.09	2-2478	.10	2-2493	.15	2-2508	.15
3/8			2-2453	.07	2-2465	.09	2-2479	.10	2-2494	.16	2-2509	.16
7/16					2-2466	.09	2-2480	.11				
1/2	2-2458	.08	2-2455	.08	2-2467	.09	2-2481	.11	2-2496	.17	2-2511	.14
5/8			2-2456	.09	2-2468	.09	2-2482	.11	2-2497	.18	2-2512	.18
3/4			2-2457	.09	2-2469	.10	2-2483	.12	2-2498	.19	2-2513	.19
7/8					2-2475	.11	2-2495	.13	2-2499	.20	2-2514	.20
1			2-2459	.10	2-2471	.11	2-2485	.14	2-2500	.21	2-2515	.21
1 1/4			2-2641	.11	2-2472	.13	2-2486	.14	2-2501	.23	2-2516	.23
1 1/2	2-2470	.12					2-2487	.18	2-2502	.26	2-2517	.26
1 3/4									2-2503	.29	2-2518	.29
2							2-2489	.22	2-2504	.32	2-2519	.33
2 1/4											2-2522	.38
2 1/2							2-2490	.26	2-2505	.42	2-2520	.42
3							2-2491	.27	2-2506	.49	2-2521	.49
3 1/2											2-2523	.84

SIZE:	12-24		1/4-20		1/4-28		5/16-18		3/8-16		1/2-13	
LENGTH	PART#	\$	PART#	\$	PART#	\$	PART#	\$	PART#	\$	PART#	\$
3/8	2-2524	.19	2-2580	.27	2-2594	.45						
1/2	2-2526	.22	2-2581	.28	2-2595	.48	2-2602	.45	2-7850	.65		
5/8	2-2527	.24	2-2582	.30			2-2603	.49				
3/4	2-2528	.25	2-2583	.32	2-2597	.53	2-2604	.54	2-2617	.78		
7/8	2-2525	.29										
1	2-2530	.31	2-2585	.35	2-2599	.58	2-2606	.59	2-2619	.88		
1 1/4	2-2531	.37	2-2586	.40	2-2600	.61	2-2607	.62	2-2620	.92		
1 1/2	2-2532	.39	2-2587	.48	2-2601	.67	2-2608	.68	2-2621	.96		
1 3/4			2-2588	.49			2-2609	.99				
2	2-2534	.46	2-2589	.52			2-2610	.77	2-2623	1.14		
2 1/2			2-2590	.58			2-2611	.79	2-2624	1.25	2-2629	3.80
3			2-2591	.69			2-2612	.84	2-2625	1.98		
3 1/2			2-2592	.84			2-2613	.90	2-2626	2.49		

SLOTTED ROUND MACHINE SCREW SHOP ASSORTMENT: 1720 PIECES # 3-3056 \$ 347.75  
 PERSONAL ASSORTMENT: 850 PIECES 3-3175 170.00

# TRUSS MACHINE SCREWS

- PHILLIPS HEAD -

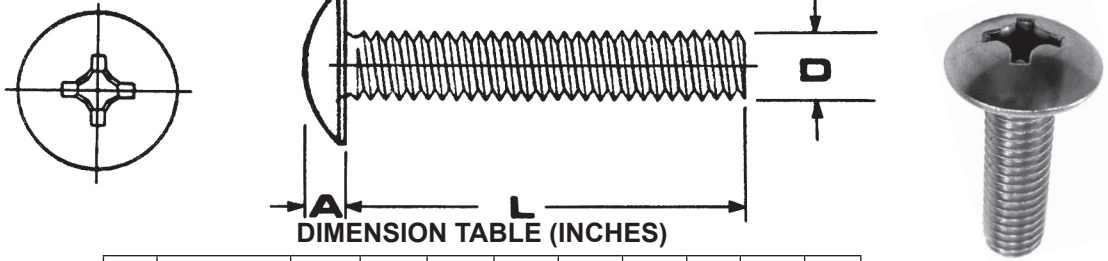

DIMENSION TABLE (INCHES)

D	DIAMETER	.112	.138	.164	.190	.190	.220	1/4	5/16	3/8
A	HEAD HT.	.069	.086	.102	.118	.118	.125	.15	.18	.22
B	HEAD DIA.	.257	.321	.384	.448	.448	.500	.57	.64	.81
ISO #		4	6	8	10	10	12			
THREADS/INCH		40	32	32	24	32	24	20	18	16

## PART NUMBER AND PRICE GUIDE

SIZE:	4-40		6-32		8-32		10-24		10-32		12-24		1/4-20	
LENGTH	PART#	\$	PART#	\$	PART#	\$	PART#	\$	PART#	\$	PART#	\$	PART#	\$
1/4	2-3051	.04	2-3058	.05	2-3067	.08	2-3316	.09	2-3319	.09				
5/16	2-3052	.05	2-3059	.05	2-3068	.07								
3/8	2-3053	.05	2-3060	.06	2-3069	.08	2-3078	.10	2-3087	.10			2-3095	.17
1/2	2-3054	.05	2-3061	.06	2-3070	.09	2-3079	.11	2-3088	.11	2-3126	.24	2-3096	.19
5/8			2-3062	.07	2-3071	.10	2-3080	.12	2-3089	.13	2-3312	.26	2-3097	.21
3/4	2-3055	.09	2-3063	.08	2-3072	.11	2-3081	.15	2-3090	.14	2-3313	.29	2-3098	.23
7/8					2-3314	.12								
1			2-3064	.09	2-3073	.12	2-3082	.17	2-3091	.16			2-3099	.27
1 1/4			2-3065	.09	2-3074	.14	2-3083	.19	2-3092	.19			2-3100	.31
1 1/2			2-3066	.09	2-3075	.16	2-3084	.20	2-3093	.20			2-3101	.35
1 3/4					2-3315	.19	2-3317	.24	2-3320	.24			2-3321	.37
2							2-3085	.27	2-3094	.26			2-3102	.39
2 1/4							2-3318	.35					2-3323	.42
2 1/2							2-3108	.39					2-3014	.44
3							2-3197	.44					2-3104	.49
3 1/2									2-3086	.87				

PHILLIPS TRUSS  
MACHINE SCREW  
SHOP ASSORTMENT:  
1720 PIECES  
# 3-3034 \$ 245.75

PHILLIPS TRUSS  
MACHINE SCREW  
PERSONAL  
ASSORTMENT: 850  
PIECES  
# 3-3168 \$ 130.00

SIZE:	5/16-18		3/8-16	
LENGTH	PART#	\$	PART#	\$
1/2	2-3322	.43		
5/8	2-3198	.45		
3/4	2-3107	.49	2-3325	.99
1	2-3025	.53	2-3186	1.18
1 1/4	2-3004	.55	2-3194	1.29
1 1/2	2-3034	.57		
2	2-3005	.69		
2 1/4			2-3192	1.98
2 1/2	2-3106	1.09	2-3193	2.46

# TRUSS SOCKET MACHINE SCREWS

\*BUTTON HEADS WITH BIGGER HEADS! GREAT FOR HANGING REAR FENDERS ON STEPSIDE TRUCKS!

SIZE:	12-24		1/4-20		5/16-18	
LENGTH	PART#	\$	PART#	\$	PART#	\$
1/2	2-3076	.49	2-3137	.59		
5/8			2-3350	.62		
3/4	2-3103	.54	2-3185	.64	2-3195	.96
1	2-3116	.59	2-3191	.69	2-3196	1.19
1 1/4					2-3327	1.30



# TRUSS MACHINE SCREWS

- SLOTTED HEAD -

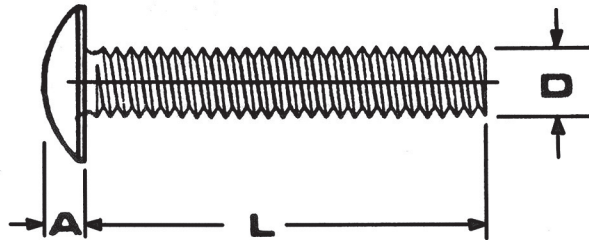
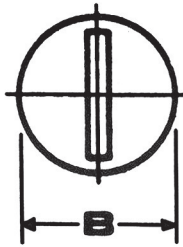

DIMENSION TABLE (INCHES)

D	DIAMETER	.112	.138	.164	.190	.190	1/4	5/16
A	HEAD HT.	.069	.086	.102	.118	.118	.15	.18
B	HEAD DIA.	.257	.321	.384	.448	.448	.57	.64
	ISO #	4	6	8	10	10		
	THREADS/INCH	40	32	32	24	32	20	18

PART NUMBER AND PRICE GUIDE

SIZE:	4-40		6-32		8-32		10-24		10-32		1/4-20		1/4-28		5/16-18	
LENGTH	PART#	\$	PART#	\$	PART#	\$	PART#	\$	PART#	\$	PART#	\$	PART#	\$	PART#	\$
1/4	2-3000	.04	2-3007	.08	2-3016	.09	2-3306	.12	2-3309	.12						
5/16	2-3001	.05	2-3008	.09	2-3017	.09			2-3310	.13						
3/8	2-3002	.05	2-3009	.09	2-3018	.09	2-3026	.13	2-3035	.13	2-3043	.26				
1/2	2-3003	.05	2-3010	.09	2-3019	.10	2-3027	.14	2-3036	.14	2-3044	.27	2-3351	.28	2-3172	.38
5/8			2-3011	.09	2-3020	.11	2-3028	.15	2-3037	.15	2-3045	.29	2-3180	.31	2-3142	.44
3/4	2-3056	.09	2-3012	.10	2-3021	.12	2-3029	.15	2-3038	.15	2-3046	.31			2-3331	.48
7/8							2-3354	.16								
1	2-3006	.09	2-3013	.11	2-3022	.13	2-3030	.16	2-3039	.16	2-3047	.35	2-3352	.36	2-3077	.53
1 1/4			2-3302	.25	2-3023	.36	2-3031	.37	2-3040	.38	2-3048	.57			2-3346	.81
1 1/2			2-3303	.37	2-3024	.38	2-3032	.39	2-3041	.40	2-3049	.59			2-3347	.92
1 3/4							2-3311	.41			2-3356	.60			2-3353	.99
2					2-3305	.40	2-3033	.43	2-3042	.44	2-3050	.68			2-3177	1.24
2 1/2							2-3307	.49			2-3329	.85				
3							2-3308	.56			2-3330	.89				

SLOTTED TRUSS ADDITIONAL SIZES: 12-24 X 1/2 # 2-3355 \$ .24  
 12-24 X 1 2-3328 .30  
 3/8-16 X 1 2-3348 1.29  
 3/8-16 X 1 1/4 2-3349 1.59  
 3/8-16 X 1 1/2 2-3015 1.69

SLOTTED TRUSS MACHINE SCREW SHOP ASSORTMENT: 1720 PIECES # 3-3057 \$ 351.50  
 PERSONAL ASSORTMENT: 850 PIECES 3-3164 148.00

# UNSLOTTED TRUSS MACHINE SCREWS

- USED TO REPLACE RIVETS -

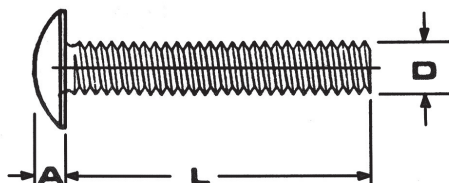
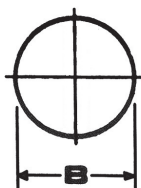

SIZE:	6-32		8-32		10-32	
LENGTH	PART#	\$	PART#	\$	PART#	\$
1/2	2-3057	.50				
5/8			2-3199	.75	2-3105	.79
3/4	2-3359	.55				

# HEX SOCKET SET SCREWS

## LONG SET SCREWS WORK GREAT AS STUDS!



D	DIAMETER	.112	.138	.164	.190	.190	1/4	1/4	5/16	5/16	3/8	3/8	1/2
C	KEY SIZE	.050	1/16	5/64	3/32	3/32	1/8	1/8	5/32	5/32	3/16	3/16	1/4
ISO #		4	6	8	10	10							
THREADS/INCH		40	32	32	24	32	20	28	18	24	16	24	13

### PART NUMBER AND PRICE GUIDE

SIZE:	4-40		6-32		8-32		10-24		10-32		1/4-20	
LENGTH	PART#	\$	PART#	\$	PART#	\$	PART#	\$	PART#	\$	PART#	\$
1/8	2-1703	.08	2-1708	.09	2-1720	.09						
3/16	2-1701	.08	2-1709	.09	2-1721	.09	2-1730	.11	2-1737	.13	2-1748	.13
1/4	2-1702	.10	2-1710	.10	2-1722	.11	2-1731	.12	2-1738	.14	2-1749	.13
5/16			2-1711	.11	2-1723	.11	2-1732	.13	2-1739	.15	2-1750	.16
3/8	2-1704	.12	2-1712	.12	2-1724	.12	2-1733	.14	2-1740	.16	2-1751	.17
1/2	2-1705	.14	2-1713	.14	2-1725	.14	2-1734	.15	2-1741	.19	2-1752	.19
5/8	2-1706	.19	2-1714	.17					2-1742	.21	2-1754	.22
3/4			2-1715	.18	2-1726	.19	2-1735	.24	2-1743	.24	2-1755	.24
1			2-1716	.25	2-1727	.25	2-1745	.24	2-1744	.27	2-1756	.25
1 1/4									2-1746	.30	2-1753	.36
1 1/2			2-1717	.49							2-1757	.47
2											2-1758	.59
2 1/2											2-1759	1.40
3											2-1736	1.58

SIZE:	1/4-28		5/16-18		5/16-24		3/8-16		3/8-24		1/2-13	
LENGTH	PART#	\$	PART#	\$	PART#	\$	PART#	\$	PART#	\$	PART#	\$
3/16	2-1760	.18										
1/4	2-1762	.18	2-1770	.22	2-1780	.30	2-1789	.27	2-1796	.37		
5/16	2-1763	.19	2-1771	.26	2-1781	.31	2-1790	.31				
3/8	2-1764	.19	2-1772	.28	2-1782	.32	2-1791	.32	2-1798	.39	2-1805	.59
1/2	2-1765	.23	2-1773	.35	2-1783	.37	2-1792	.39	2-1799	.42	2-1806	.62
5/8	2-1747	.29	2-1774	.36			2-1793	.46				
3/4	2-1767	.33	2-1761	.42			2-1794	.53	2-1801	.59	2-1808	.85
1	2-1768	.36	2-1777	.46	2-1786	.48	2-1776	.69	2-1802	.74	2-1809	.98
1 1/4			2-1778	.61	2-1787	.62	2-1795	.79	2-1797	1.39		
1 1/2	2-1718	.49	2-1779	.72			2-1818	.89				
2			2-1788	1.02			2-1819	1.29				
2 1/2			2-1775	1.42			2-1700	2.85				
3			2-1766	2.01			2-1800	3.70				

ADDITIONAL SIZES: 7/16-14 X 1/2 # 2-7300 \$.69      7/16-20 X 1/2 # 2-1784 \$.68      1/2-13 X 2 1/4      2-1817      2.69  
 X 3/4 # 2-1785 .79      X 3/4 # 2-1707 \$.99      1/2-20 X 3/4      2-1719      1.16

**PERSONAL ASSORTMENT: 345 PIECES    3-3141    130.00**



**TOLL FREE ORDER LINE : 1-800-767-4781**



# HIGH STRENGTH STUDS

SIZE:	1/4-20/28		5/16-18/24		3/8-16/24	
LENGTH	PART#	\$	PART#	\$	PART#	\$
1 1/8	2-1916	7.81				
1 1/2	2-1906	7.94				
1 5/8			2-1901	8.05	2-1905	9.16
1 3/4	2-1907	8.11	2-1914	8.25		
2					2-1902	9.31
2 1/4	2-1908	8.88	2-1904	8.80		
2 1/2					2-1915	9.55
2 3/4	2-1912	9.33	2-1911	8.98		
3	2-1913	9.90				
3 1/4			2-1910	9.22		
3 3/4					2-1903	11.62

**170,000 PSI STUDS  
-GREAT FOR EXHAUST MANIFOLDS-**



**LOWER STUD PICTURED ABOVE**  
 7/16-14/14 X 2 #2-7054 \$9.75  
 7/16-14/14 X 2 1/2 2-7053 13.79  
 7/16-14/14 X 2 3/4 2-7056 13.95

**\*USED ON MOST STOCK FOR EXHAUST MANIFOLDS\*  
-BOTH ENDS ARE COARSE THREAD-**

**\*\*WE CUSTOM MAKE STUDS IN 300 SERIES AND 17-4 STAINLESS, SEE EXAMPLES BELOW.  
JUST CALL US WITH THE SIZE YOU NEED!**

## **CUSTOM MADE 17-4 PH STUDS - MADE TO ORDER - NOT STOCK ITEMS**

PART #	THREAD	OVERALL LENGTH	THREAD LENGTH	PRICE
2-7011	3/8-24	1.71	.65" OF THREAD ON EACH END	12.49
2-7012	3/8-24	2.04	.65" ON ONE END & .80" ON THE OTHER	12.74
2-7013	3/8-24	2.18	.63" ON ONE END & 1.18" WITH THE DOG POINT END FOR 1955-57 T-BIRDS	12.98
2-7023	3/8-16/24	2.25	.5625" OF 3/8-16 & .6875" OF 3/8-24 ON THE BALL END	16.96
2-7024	3/8-16	2.25	1" ON ONE END & 1.125" ON THE OTHER	12.79
2-7046	3/8-16	2.69	1" ON ONE END & 1.125" ON THE OTHER	12.97
2-6993	3/8-16	3	1" OF THREAD ON EACH END	12.90
2-7021	3/8-16	3-1/4	1-1/4" OF THREAD ON EACH END	13.34
2-7050	3/8-16	7	.5" ON ONE END & 1.5" ON THE OTHER (SWAY BAR)	13.78
2-7098	3/8-16	8	.5" ON ONE END & 1.5" ON THE OTHER (SWAY BAR)	14.57
2-7051	3/8-16	8.5	.5" ON ONE END & 1.5" ON THE OTHER (SWAY BAR)	14.99
2-7053	7/16-14	2.5	1" ON EACH END	13.79
2-7081	7/16-14	7	1/2" ON ONE END AND 1" ON THE OTHER	20.66
2-7082	7/16-14	7.5	1/2" ON ONE END AND 1" ON THE OTHER	20.98
2-7086	7/16-14	8	1/2" ON ONE END AND 1" ON THE OTHER	21.58
2-7150	1/2-13	7	1/2" ON ONE END AND 1 1/4" ON THE OTHER	22.98
2-7067	7/16-14/20	3.5	.75" ON THE 7/16-14 END & 1.25" ON THE 7/16-20 END	19.86
2-7059	7/16-14/20	4.5	1" ON THE 7/16-14 END & .8125" ON THE 7/16-20 END	20.99
2-7058	7/16-14/20	5.75	1.25" ON THE 7/16-14 END & .625" ON THE 7/16-20 END	21.46
2-7064	7/16-14/20	7	1" ON THE 7/16-14 END & .5" ON THE 7/16-20 END	21.84
2-7063	7/16-14/20	7.5	1" ON THE 7/16-14 END & .5" ON THE 7/16-20 END	22.96
2-7066	7/16-20	7.62	1" ON ONE END & 1.25" ON THE OTHER	21.77
2-7068	1/2-13/20	4	1.125" ON 1/2-13 END & 1.3125 ON THE 1/2-20 END	24.98
2-7074	1/2-13/20	4.5	2" ON 1/2-13 END & 1.3125 ON THE 1/2-20 END	25.76
2-7076	1/2-13/20	6.16	2" ON 1/2-13 END & 1.3125 ON THE 1/2-20 END	27.59
2-7085	5/8-11/18	8.5	1.25" ON THE 5/8-11 END & 1.75 ON THE 5/8-18 END	37.68

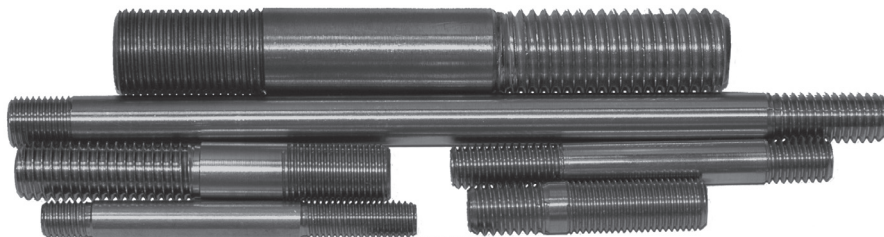

## STANDARD 18-8 SS SHOULDER BOLTS

D	THREAD	T	A	H	KEY SIZE
5/16	1/4-20	7/16	7/16	7/32	5/32
3/8	5/16-18	1/2	9/16	1/4	3/16
1/2	3/8-16	5/8	3/4	5/16	1/4

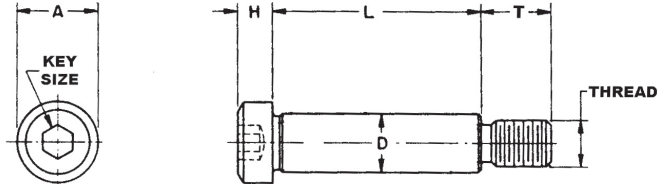

SIZE (D)		5/16		3/8		1/2	
LENGTH (L)	PART #	\$	PART #	\$	PART #	\$	
5/16	2-8218	3.75					
3/8	2-8219	4.00	2-8238	4.25	2-8271	4.35	
1/2	2-8220	4.15	2-8239	4.35	2-8272	4.50	
5/8	2-8221	4.25	2-8240	4.50	2-8273	4.65	
3/4	2-8222	4.30	2-8241	4.65	2-8274	4.75	
1	2-8223	4.50	2-8242	4.75	2-8275	5.00	
1 1/4	2-8224	4.65	2-8243	5.00	2-8276	5.25	
1 1/2			2-8244	5.25	2-8277	5.50	



OUR CUSTOM MADE SHOULDER BOLTS ARE MADE FROM HIGH STRENGTH 17-4 PH SS SUCH AS IN THE KITS AT THE RIGHT:

**8) BOLTS FOR 1949-51 MERCURY HOOD HINGES:**  
 BUTTON HEAD 9-5000 154.00  
 HEX HEAD 9-5001 155.00

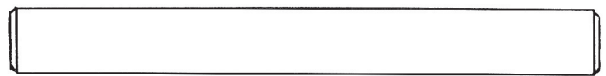

## THREADED & BAR STOCK

- ALL ROD IS SOLD IN FEET -

- 3 FOOT MAXIMUM FOR THREADED ROD & UNTHREADED - \$5.00 SURCHARGE FOR 2 TO 3 FOOT PIECES

### THREADED

SIZE	PART#	\$
6-32	2-1350	1.95
8-32	2-1351	2.30
10-24	2-1352	2.85
10-32	2-1353	2.85
12-24	2-1324	2.89
1/4-20	2-1354	2.96
1/4-28	2-1355	2.96
5/16-18	2-1356	3.30
5/16-24	2-1357	3.70
3/8-16	2-1358	3.90
3/8-24	2-1359	4.40

SIZE	PART#	\$
7/16-14	2-1369	5.80
7/16-20	2-1370	6.90
1/2-13	2-1360	6.40
1/2-20	2-1361	7.40
9/16-18	2-1331	16.60
5/8-11	2-1364	6.90
5/8-18	2-1362	7.90
3/4-10	2-1366	8.90
3/4-16	2-1367	12.50

### 303 SS HEX BAR

SIZE	PART#	\$
3/8	2-1343	4.90
7/16	2-1365	8.80
1/2	2-1380	12.70
9/16	2-1372	14.40
5/8	2-1373	16.60
3/4	2-1374	24.90
7/8	2-1383	32.40
15/16	2-1338	47.80
1	2-1346	36.60
1-1/16	2-1339	48.50

### 303 SS SQUARE BAR

SIZE	PART#	\$
5/8	2-1347	15.80
3/4	2-1368	19.60
7/8	2-1334	33.70
1	2-1385	44.60

### 303 SS ROUND

SIZE	PART#	\$
3/16	2-1388	2.40
1/4	2-1392	2.90
5/16	2-1393	4.30
3/8	2-1394	5.50
7/16	2-1395	7.50
1/2	2-1396	8.60
9/16	2-1340	10.90
5/8	2-1397	11.90
3/4	2-1398	16.90
7/8	2-1384	18.60
1	2-1399	19.90
1 1/4	2-1390	34.50
1 1/2	2-1386	57.00
1 3/4	2-1389	68.00
2	2-1391	88.00
2 1/4	2-1349	94.00
2 1/2	2-1332	99.00

### 17-4 PH HIGH STRENGTH ROUND BAR

HEAT TREATED TO H925  
 STRONGER THAN GRADE 8  
 STEEL BOLTS IN STRENGTH

SIZE	PART#	\$
3/8	2-1375	10.95
7/16	2-1376	11.80
1/2	2-1377	12.90
9/16	2-1333	15.20
5/8	2-1378	18.30
3/4	2-1379	25.90
7/8	2-1330	33.40
1	2-1363	40.80

### 17-4PH (annealed) HEX

SIZE	PART#	\$
5/8	2-1341	25.80
3/4	2-1345	30.70
7/8	2-1336	60.60
1	2-1335	89.70

### 304 1/2 ROUND BAR 1/2" WIDE - 2-9905 \$8.80/FT

# HIGH STRENGTH U-BOLTS

WE USE THESE U-BOLTS IN OUR SUSPENSION KITS  
 - THEY EQUAL OR EXCEED 'GRADE 8'  
 \*MADE IN THE USA FROM 17-4 PH HEAT TREATED  
 CERTIFIED STAINLESS!\*

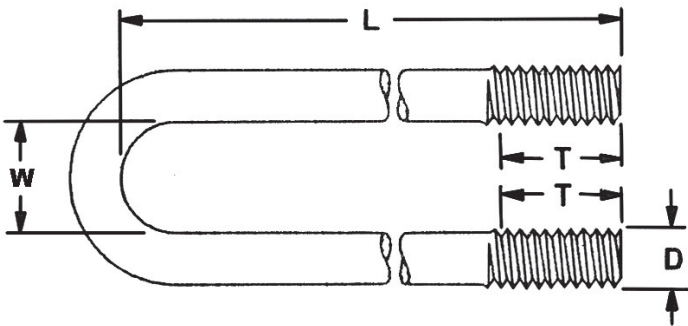

**\*NOTE\* "L" MUST BE EQUAL TO OR GREATER THAN W+T**

**\* WE CUSTOM MAKE U-BOLTS TO YOUR SPECIFICATIONS UP TO 5/8"\***  
**303 SS OR 17-4 PH**

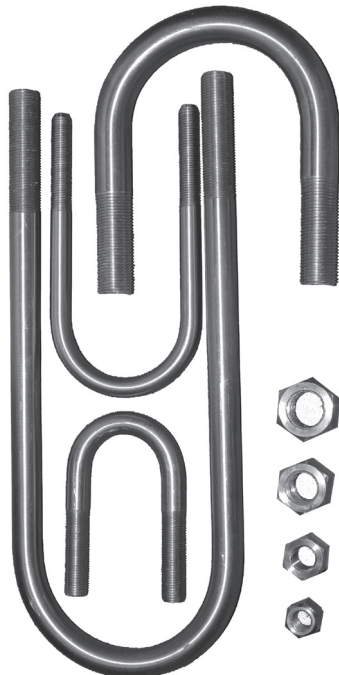

PART#	STK	\$	D	L	W	T
2-3750		22.90	3/8-24	6	2 3/8	2
2-3698	*	23.50	7/16-20	5 1/2	2 3/8	2 1/2
2-3696		29.40	7/16-20	8	2 3/8	2 1/2
2-3699	*	23.80	7/16-20	7	2 25/32	2 3/4
2-3761		31.70	7/16-20	8	2 25/32	2 1/2
2-3700		23.90	7/16-20	6 3/4	3 1/16	2 1/2
2-3730		27.60	1/2-20	5 1/2	2 3/8	2 1/2
2-3719		29.80	1/2-20	7	2 3/8	2 1/2
2-3702	*	22.90	1/2-20	3 1/4	1 9/16	1 3/4
2-3704	*	27.40	1/2-20	6	2 9/16	2 1/2
2-3701		28.40	1/2-20	7	2 9/16	2 1/2
2-3711	*	28.60	1/2-20	7	2 3/4	2 1/2
2-3735		31.90	1/2-20	7 3/4	2 7/8	2 1/2
2-3718		32.80	1/2-20	8 1/2	2 7/8	2 1/2
2-3717	*	28.40	1/2-20	6	3 1/16	2 1/2
2-3705	*	28.70	1/2-20	6 3/4	3 1/16	2 1/2
2-3712	*	33.90	1/2-20	8 1/2	3 1/16	2 1/2
2-3729		36.70	1/2-20	10	3-1/6	2
2-3706	*	28.80	1/2-20	6 1/2	3 1/4	2 1/2
2-3707	*	33.90	1/2-20	8	3 1/4	2 1/2
2-3771		35.90	9/16-18	7 1/2	3 1/16	2
2-3767		35.90	9/16-18	7	3 5/16	2
2-3774		36.60	9/16-18	6 3/4	3 3/8	2
2-3733		35.90	5/8-18	7 1/2	2 13/16	2
2-3708	*	36.60	5/8-18	7	3 1/16	2
2-3721		37.50	5/8-18	8 1/2	3 1/16	2
2-3723		38.90	5/8-18	9	3 1/16	2
2-3720		39.80	5/8-18	8 1/2	3 3/16	2
2-3726		43.90	5/8-18	10	3 3/16	2
2-3725		37.90	5/8-18	8 1/4	3 5/8	2
2-3709	*	38.50	5/8-18	9	3 5/8	2
2-3728		43.90	5/8-18	9 1/2	3 7/16	2
2-3722		48.60	5/8-18	11 1/2	3 7/16	2
2-3732		44.90	5/8-18	9 1/2	3 3/4	2
2-3724		45.80	5/8-18	10 1/2	3 3/4	2

\*DESIGNATES STOCK SIZES - OTHER SIZES MADE TO ORDER

## TALL NUTS FOR U-BOLTS

17-4 PH STAINLESS - MINIMUM YIELD STRENGTH IS 110,000 PSI, MINIMUM TENSILE IS 140,000 PSI

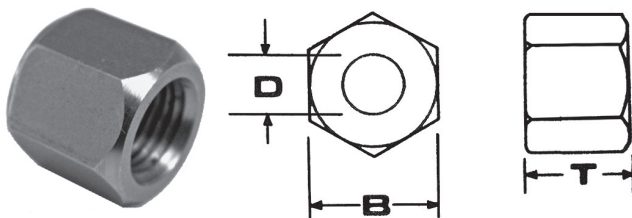

SIZE (D)	WRENCH (B)	T	PART#	\$
3/8-24	5/8	.58	2-4568	16.00
7/16-20	5/8	.58	2-4181	16.50
1/2-20	3/4	.67	2-4182	17.50
9/16-18	7/8	.75	2-4185	19.95
5/8-18	15/16*	.83	2-4183	22.95
3/4-16	1 1/16*	.98	2-4184	25.95

\*B DIMENSION MAY VARY: 5/8 (7/8 OR 15/16") & 3/4-16 (1" OR 1 1/16") DEPENDING ON MATERIAL AVAILABILITY

TOLL FREE ORDER LINE : 1-800-767-4781

# US HEX NUTS

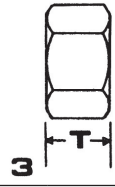
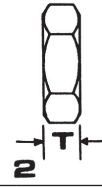
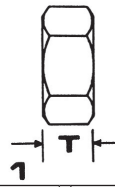
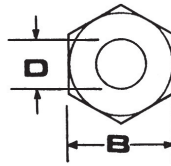
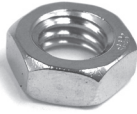

D SIZE	THDS/ INCH	B WRENCH	FULL HEX			JAM			HEAVY			HEAVY JAM			
			T1	PART#	\$	T2	PART#	\$	WRENCH	T3	PART#	\$	T2	PART#	\$
- COARSE THREAD -															
#2	56	3/16	1/16	2-4038	.05										
#4	40	1/4	3/32	2-4000	.04										
#5	40	5/16	7/64	2-4573	.05										
#6	32	5/16	7/64	2-4001	.05										
#8	32	11/32	1/8	2-4002	.06										
#10	24	3/8	1/8	2-4003	.07										
#12	24	7/16	5/32	2-4004	.08										
1/4	20	7/16	7/32	2-4005	.09	5/32	2-4024	.11	1/2	1/4	2-4101	.18	3/16	2-4511	.69
5/16	18	1/2	17/64	2-4006	.12	3/16	2-4025	.16	9/16	5/16	2-4102	.28	7/32	2-4107	.76
3/8	16	9/16	21/64	2-4007	.18	7/32	2-4026	.21	11/16	3/8	2-4103	.49	1/4	2-4108	.98
7/16	14	11/16	3/8	2-4008	.37	1/4	2-4027	.36			2-4668	1.39			
1/2	13	3/4	7/16	2-4009	.39	5/16	2-4028	.49	7/8	15/32	2-4104	.89	5/16	2-4177	1.70
9/16	12	7/8	15/32	2-4042	1.27	5/16	2-4031	1.19							
5/8	11	15/16	35/64	2-4010	.94	3/8	2-4029	.79	1 1/16	3/8	2-4105	1.89	3/8	2-4172	2.50
3/4	10	1 1/8	41/64	2-4049	1.46	7/16	2-4023	.98					7/16	2-4513	5.80
7/8	9	1 5/16	23/32	2-4186	1.25										
1	8	1 1/2	55/64	2-4146	3.96	25/46	2-4022	2.10							
- FINE THREAD -															
#4	48	1/4	3/32	2-4011	.10										
#6	40	5/16	7/64	2-4012	.18										
#8	36	11/32	1/8	2-4013	.18										
#10	32	3/8	1/8	2-4014	.07										
1/4	28	7/16	7/32	2-4016	.11	5/32	2-4032	.11	1/2	1/4	2-4147	.19			
5/16	24	1/2	17/64	2-4017	.15	3/16	2-4033	.18	9/16	5/16	2-4148	.49	7/32	2-4115	.82
3/8	24	9/16	21/64	2-4018	.21	7/32	2-4034	.21	11/16	5/8	2-4158	.79			
7/16	20	11/16	3/8	2-4019	.44	1/4	2-4035	.39							
1/2	20	3/4	7/16	2-4020	.54	5/16	2-4036	.49	7/8	15/32	2-4670	1.48			
9/16	18	7/8	31/64	2-4015	1.28	5/16	2-4030	1.44							
5/8	18	15/16	35/64	2-4021	1.26	3/8	2-4037	.98							
11/16	16	15/16				3/8	2-4173	4.90							
11/16	18	1 1/16				3/8	2-4514	6.90							
3/4	16	1 1/8	41/64	2-4197	1.69	7/16	2-4050	1.39							
7/8	14	1 5/16	23/32	2-4586	1.88	1/2	2-4189	1.90							
7/8	16	1 1/4				7/16	2-4516*	8.90							
7/8	20	1 1/4				7/16	2-4593	9.80							
1	14	1 1/2	55/64	2-4051	3.99	9/16	2-4110	2.10							

\* JAM NUT FOR 55-57 STEERING ARM \*

SHOP ASSORTMENT: HEX & JAM NUTS - COARSE & FINE THREAD - 1425 PC - 24 COMPARTMENT: 3-3079 \$315.50

QUANTITY DISCOUNTS: 20% off of 100 of any one size of fastener, 30% off of 500, 36% of 1000. Call for quotes on larger quantities. Quantity discounts above the 100 piece level do not apply to all items.

WHOLESALE: Interested in resale of our products? Call for more information on dealer discounts!



# US ACORN NUTS

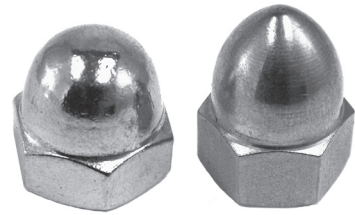
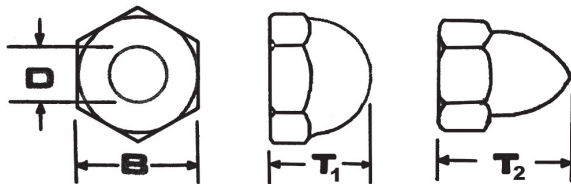

D (SIZE)	THDS/ INCH	B WRENCH	ACORN			HIGH CROWN			
			T1	PART#	\$	WRENCH	T2	PART#	\$
<b>- COARSE THREAD -</b>									
#6	32	5/16	11/32	2-4039	.28				
#8	32	11/32	11/32	2-4040	.29				
#10	24	3/8	13/32	2-4041	.30	3/8	33/64	2-4090	1.39
#12	24	3/8	13/32	2-4099	.98				
1/4	20	7/16	15/32	2-4043	.39	7/16	19/32	2-4091	1.46
5/16	18	9/16	17/32	2-4044	.68	1/2	11/16	2-4092	1.90
3/8	16	5/8	5/8	2-4045	.89	9/16	25/32	2-4093	2.70
7/16	14	5/8	11/16	2-4046	2.49	5/8	7/8	2-4094	3.95
1/2	13	3/4	13/16	2-4047	1.49	3/4	1 1/32	2-4095	5.75
5/8	11	1	1	2-4048	4.80				
<b>- FINE THREAD -</b>									
#10	32	3/8	13/32	2-4052	.30	3/8	33/64	2-4190	1.39
1/4	28	7/16	15/32	2-4053	.48	7/16	19/32	2-4191	1.46
5/16	24	9/16	17/32	2-4054	.89	1/2	11/16	2-4192	1.90
3/8	24	5/8	5/8	2-4055	.98	9/16	25/32	2-4193	2.70
7/16	20	5/8	11/16	2-4056	3.75	5/8	7/8	2-4194	3.95
1/2	20	3/4	13/16	2-4057	1.99	3/4	1 1/32	2-4195	5.75
9/16	18	7/8	7/8	2-4165	14.90				
5/8	18	1	1	2-4058	7.90	15/16	1 5/16	2-4196	11.80
3/4	16	1 1/8	1 3/16	2-4162	16.75	1 1/16	1 1/2	2-4175	18.90

## ADDITIONAL SIZES:

- 4-40 ACORN NUT  
# 2-4198 \$ .49
- 9/16-12 ACORN NUT  
# 2-4199 \$ 14.90
- 7/8-14 ACORN NUT  
# 2-4176 \$ 24.80

## - COARSE THREAD NUT ASSORTMENT: 1010 PIECES

- INCLUDES HEX, ACORN, NYLON, & WING NUTS
- # 3-3010 \$ 265.00
- 10-24 THRU 3/8-16

## - FINE THREAD NUT ASSORTMENT: 1245 PIECES

- INCLUDES HEX, JAM, ACORN, NYLON & WING NUTS
- # 3-3022 \$ 276.50
- 10-32 THRU 3/8-24

## SERRATED FLANGE

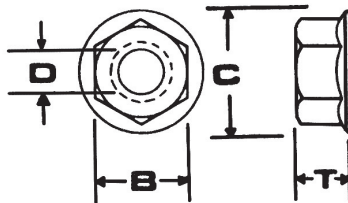

## KEP

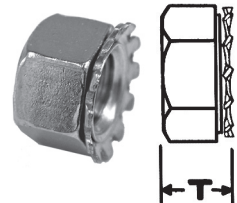

## WING NUTS

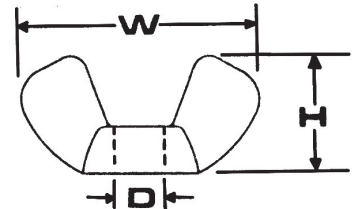

D (SIZE)	THDS/ INCH	B WRENCH	SERRATED FLANGE NUTS				KEP NUTS			WING NUTS			
			C	T1	PART#	\$	T2	PART#	\$	W	H	PART#	\$
#4	40	1/4					1/8	2-4178	.06				
#6	32	5/16	13/32	5/32	2-4164	.13	9/64	2-4128	.07	.61	23/64	2-4136	.28
#8	32	11/32	15/32	3/16	2-4121	.13	5/32	2-4129	.09	.81	13/32	2-4137	.32
#10	24	3/8	1/2	13/64	2-4122	.14	5/32	2-4130	.11	.81	13/32	2-4138	.33
#10	32	3/8	1/2	13/64	2-4123	.14	5/32	2-4131	.11	.81	13/32	2-4139	.33
#12	24				2-4518	.34							
1/4	20	7/16	19/32	7/32	2-4124	.19	15/64	2-4132	.17	1.03	17/32	2-4140	.36
1/4	28	7/16	19/32	7/32	2-4127	.45				1.03	17/32	2-4645	.59
5/16	18	1/2	11/16	9/32	2-4125	.47	21/64	2-4133	.28	1.13	19/32	2-4141	.49
5/16	24	1/2	11/16	9/32	2-4169	.49				1.13	19/32	2-4646	.75
3/8	16	9/16	3/4	11/32	2-4126	.55	9/16	2-4134	.39	1.39	25/32	2-4142	.69
3/8	24	9/16	3/4	11/32	2-4170	.84				1.39	25/32	2-4647	1.19
1/2	13	3/4	1 1/32	7/16	2-4171	.89				1.89	1	2-4143	1.49

# SPECIALTY NUTS

## COUPLING NUTS

**\* LOW STRENGTH \***

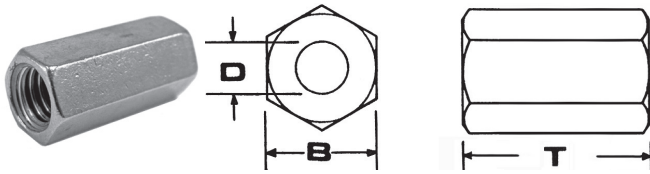

COARSE THREAD				
SIZE (D)	WRENCH (B)	T	PART#	\$
8-32	5/16	1/2	2-4555	2.10
10-24	3/8	3/4	2-4537	2.10
1/4-20	3/8	7/8	2-4538	2.25
5/16-18	7/16	1	2-4539	2.30
3/8-16	1/2	1-1/8	2-4540	2.50
7/16-14	9/16	1-1/4	2-4556	4.73
1/2-13	5/8	1-1/4	2-4557	4.75

FINE THREAD				
SIZE (D)	WRENCH (B)	T	PART#	\$
10-32	5/16	3/4	2-4560	2.10
1/4-28	3/8	7/8	2-4545	2.15
5/16-24	7/16	1	2-4546	2.75
3/8-24	1/2	1-1/8	2-4547	3.25
7/16-20	9/16	1-1/4	2-4548	7.90
1/2-20	5/8	1-1/4	2-4549	4.84

## TWELVE POINT NUTS

**- HIGH STRENGTH -**

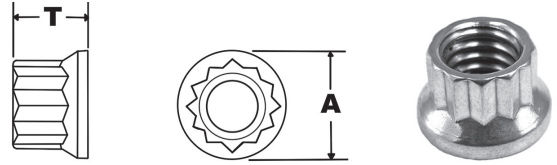

COARSE THREAD					
SIZE	WRENCH	T	A	PART#	\$
1/4-20	5/16	5/16	.43	2-4581	6.52
5/16-18	3/8	11/32	.54	2-4582	6.64
3/8-16	7/16	13/32	.63	2-4583	6.76
7/16-14	1/2	7/16	.69	2-4584	7.12
1/2-13	9/16	1/2	.82	2-4585	9.61

FINE THREAD					
SIZE	WRENCH	T	A	PART#	\$
1/4-28	5/16	5/16	.43	2-4168	6.52
5/16-24	3/8	11/32	.54	2-4149	6.64
3/8-24	7/16	13/32	.63	2-4150	6.76
7/16-20	1/2	7/16	.69	2-4188	7.12
1/2-20	9/16	1/2	.82	2-4589	9.61

## TEE NUTS

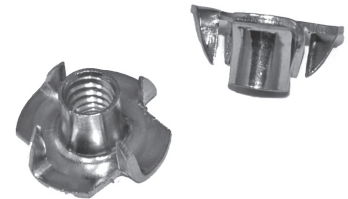

SIZE	B	T	PART #	\$
10-24	.74	.30	2-4561	.59
10-32	.74	.30	2-4571	.78
1/4-20	.75	.35	2-4562	.79
5/16-18	.88	.39	2-4563	.87
3/8-16	1.0	.48	2-4564	.99

## LEFT HAND THREAD NUTS

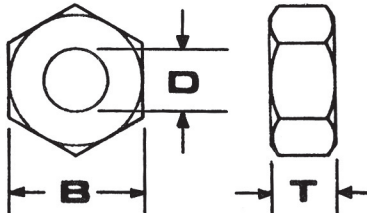

- FINE THREAD -								
D (SIZE)	THDS /INCH	B WRENCH	FULL HEX			JAM		
			T1	PART#	\$	T2	PART#	\$
10	32	3/8	1/8	2-4608	4.90			
1/4	28	7/16	7/32	2-4609	.28	5/32	2-4629	.96
5/16	24	1/2	17/64	2-4611	.59	3/16	2-4631	1.28
3/8	24	9/16	21/64	2-4613	1.20	7/32	2-4633	1.99
7/16	20	11/16	3/8	2-4615	4.49	1/4	2-4634	4.98
1/2	20	3/4	7/16	2-4617	1.95	5/16	2-4621	2.76
9/16	18	7/8	15/32	2-4624	4.99	5/16	2-4622	5.90
5/8	18	15/16	35/64	2-4637	5.50	3/8	2-4642	11.90
11/16	18 *	1 1/16	5/8	2-4627	8.99	3/8	2-4644	11.90
3/4	16	1 1/8	41/64	2-4623	5.95	3/8	2-4643	11.90

## US SQUARE NUTS

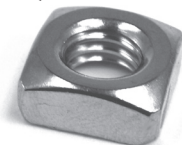

SIZE	WRENCH	T	PART#	\$
6-32	5/16	3/32	2-4587	.15
8-32	11/32	1/8	2-4159	.16
10-24	3/8	1/8	2-4152	.19
10-32	3/8	1/8	2-4153	.28
1/4-20	7/16	3/16	2-4154	.29
5/16-18	9/16	7/32	2-4155	.39
3/8-16	5/8	1/4	2-4156	.69
7/16-14	3/4	3/8	2-4578	8.50
7/16-14	7/8	7/16	2-4580	10.25
1/2-13	7/8	7/16	2-4579	10.50

**\* TIE ROD NUT FOR OLD FORDS- RIGHT HAND NUT IS #2-4514 \$7.90**  
**WE CUSTOM MAKE THE LARGER SQUARE NUTS IN**  
**OUR SHOP FROM BAR STOCK - WE STOCK 5/8" THRU**  
**1" STOCK - YOU SPECIFY THREAD TYPE & THICKNESS.**

**TOLL FREE ORDER LINE : 1-800-767-4781**

# HIGH STRENGTH US HEX NUTS

MADE IN OUR SHOP - 17-4 PH  
110,000 MIN YIELD STRENGTH  
THESE CAN BE MADE TO ANY THICKNESS

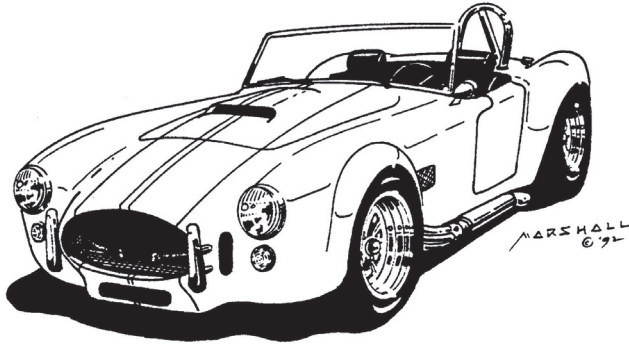
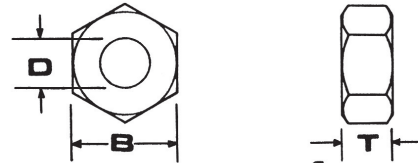

SIZE (D)	WRENCH (B)	T	PART#	\$
3/8-16	5/8	7/16	2-4522	8.79
3/8-24	5/8	7/16	2-4672	8.88
7/16-14	5/8	7/16	2-4517	8.93
7/16-20	5/8	7/16	2-4673	8.98
1/2-13	3/4	1/2	2-4567	10.69
1/2-20	3/4	1/2	2-4674	10.77
9/16-12	7/8	9/16	2-4519	12.49
9/16-18	7/8	9/16	2-4675	12.55
5/8-11	7/8*	5/8	2-4520	13.36
5/8-18	7/8*	7/16	2-4671	13.56
5/8-18	7/8*	5/8	2-4676	13.64
3/4-10	1*	11/16	2-4588	17.69
3/4-16	1*	11/16	2-4677	17.87

\*B DIMENSION MAY VARY: 5/8 (7/8 OR 15/16")  
& 3/4-16 (1" OR 1 1/16") DEPENDING ON  
MATERIAL AVAILABILITY

## SMALL PATTERN NUTS

**SIX POINT NUTS**  
(18-8 LOW STRENGTH)

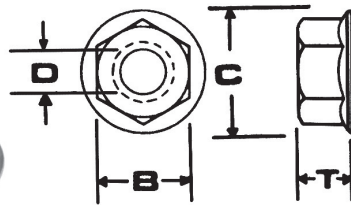

18-8 SS (LOW STRENGTH)  
DRILLED & TAPPED IN OUR SHOP

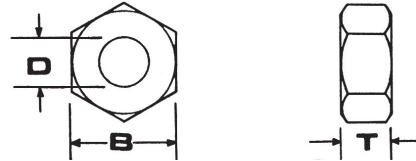

D (SIZE)	THDS/ INCH	B WRENCH	SERRATED FLANGE NUTS			
			C	T1	PART#	\$
#10	24	5/16	19/32	5/32	2-4678	2.64
#10	32	5/16	19/32	5/32	2-4679	2.64
1/4	20	3/8	1/2	13/64	2-4680	2.69
1/4	28	3/8	1/2	13/64	2-4681	2.69
5/16	18	7/16	19.32	7/32	2-4682	2.98
5/16	24	7/16	19.32	7/32	2-4683	2.98
3/8	16	7/16	19/32	7/32	2-4684	2.99
3/8	24	7/16	19/32	7/32	2-4685	2.99
7/16	14	1/2	11/16	9/32	2-4686	3.46
7/16	20	1/2	11/16	9/32	2-4687	3.46
1/2	13	9/16	3/4	11/32	2-4688	3.98
1/2	20	9/16	3/4	11/32	2-4689	3.98
9/16	12	17MM	13/16	13/32	2-4690	4.59
9/16	18	17MM	13/16	13/32	2-4691	4.59
5/8	11	3/4	1 1/32	7/16	2-4693	4.98
5/8	18	3/4	1 1/32	7/16	2-4694	4.98

D SIZE	THDS/ INCH	B WRENCH	HEX NUTS		
			T	PART#	\$
# 10	24	5/16	7/64	2-4649	3.79
# 10	32	5/16	7/64	2-4663	3.83
1/4	20	3/8	1/8	2-4666	3.85
1/4	28	3/8	1/8	2-4655	3.85
5/16	18	7/16	5/32	2-4570	4.89
5/16	18	7/16	7/32	2-4656	4.87
5/16	24	7/16	5/32	2-4657	4.89
5/16	24	7/16	7/32	2-4658	4.87
3/8	16	1/2	3/16	2-4659	4.96
3/8	16	1/2	17/64	2-4660	4.93
3/8	24	1/2	3/16	2-4661	4.96
3/8	24	1/2	17/64	2-4662	4.93

TOLL FREE ORDER LINE : 1-800-767-4781

# CASTLE & SLOTTED HEX NUTS

**HIGH STRENGTH SLOTTED TALL NUTS - MADE IN USA - COMMONLY CALLED "CASTLE NUTS" - USE THESE ON SUSPENSION PARTS (BALL JOINTS, TIE ROD ENDS, IDLER ARMS, ETC.)**

7/16, 1/2, 9/16, 5/8 SIZES ARE 17-4 PH STAINLESS WITH A MINIMUM OF 110,000 YIELD STRENGTH  
 3/4" IS 304 STAINLESS WITH A MINIMUM 70,000 YIELD STRENGTH

SIZE	B WRENCH	C COTTER KEY SIZE	PART#	\$
7/16-20	5/8	1/8 X 1-1/4 2-5015	2-4523	24.50
1/2-20	3/4	5/32x 1-1/4 2-5022	2-4525	26.50
9/16-18	7/8	5/32 X 1-1/2 2-5023	2-4527	29.50
5/8-18	15/16*	3/16 X 1-1/2 2-5029	2-4531	32.00
11/16	1-1/16*	3/16 X 1 1/2 2-5029	2-4536	34.50
3/4-16	1 1/8*	3/16 X 2 2-5030	2-4533	37.00

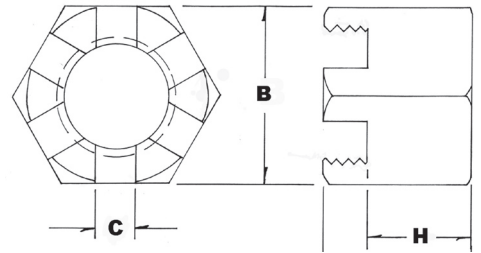
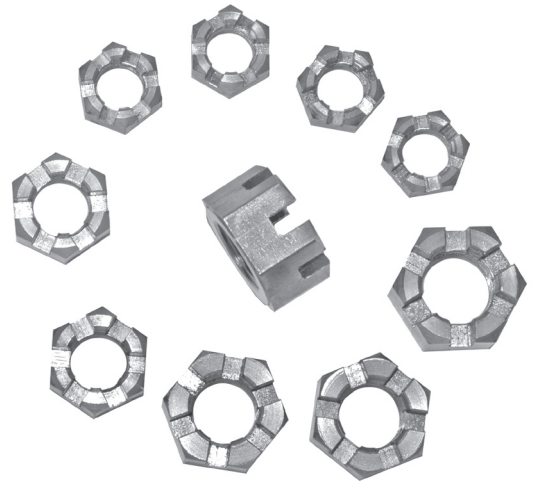

\*B DIMENSION MAY VARY: 5/8 (7/8 OR 15/16"), 11/16 (1 OR 1-1/16") & 3/4-16 (1-1/8 OR 1-1/16") DEPENDING ON MATERIAL AVAILABILITY

- WE MACHINE THE HEIGHT TO MATCH YOUR NEEDS - SPECIFY DISTANCE FROM BOTTOM OF NUT TO BOTTOM OF SLOTS (H) -

**LOW STRENGTH 18-8 CASTLE NUTS - NOT FOR USE ON SUSPENSIONS - STATE APPLICATION WHEN ORDERING 7/16 & 1/2" SIZES**



THE KIT FOR A MODEL - A TAILGATE (SHOWN ABOVE) USES 1/2-20 CASTLE NUTS THIS IS A TYPICAL LOW STRENGTH APPLICATION WHERE 18-8 CASTLE NUTS CAN BE USED

**TOLL FREE ORDER LINE:  
 1-800-767-4781**

COARSE THREAD				
SIZE	WRENCH (B)	PART#	\$	COTTER
10-24	3/8	2-4569	4.54	1/16 X 3X4
1/4-20	7/16	2-4541	4.68	1/16 X 1
5/16-18	1/2	2-4542	4.76	3/32 X 1
3/8-16	9/16	2-4543	5.67	1/8 X 1
7/16-14	5/8	2-4544	7.75	1/8 X 1 1/4
1/2-13	3/4	2-4559	7.90	5/32 X 1 1/4

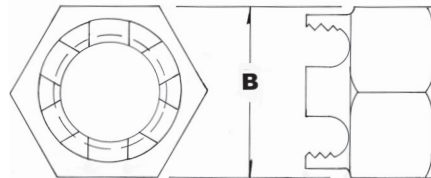

FINE THREAD				
SIZE	WRENCH (B)	PART#	\$	COTTER
10-32	3/8	2-4550	4.54	1/16 X 3X4
1/4-28	7/16	2-4551	4.69	1/16 X 1
5/16-24	1/2	2-4552	4.96	3/32 X 1
3/8-24	9/16	2-4553	5.98	1/8 X 1
7/16-20	5/8	2-4554	7.96	1/8 X 1 1/4
1/2-20	3/4	2-4521	8.80	5/32 X 1 1/4



# NYLON INSERT LOCK NUTS

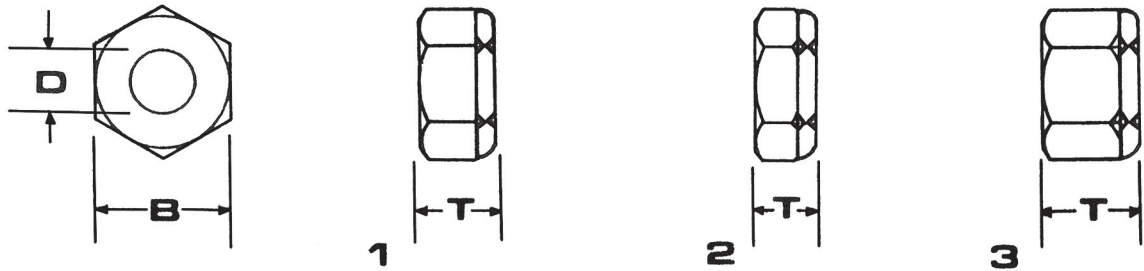

D (SIZE)	THDS/ INCH	B WRENCH	STD W/ NYLON INSERT			THIN W/ NYLON INSERT			HEAVY W/ NYLON INSERT			
			T1	PART#	\$	T2	PART#	\$	WRENCH	T3	PART#	\$
#4	40	1/4	9/64	2-4060	.06	7/64	2-4075	.14				
#5	40	1/4	9/64	2-4590	.08							
#6	32	5/16	11/64	2-4061	.07	1/8	2-4076	.12				
#8	32	11/32	15/64	2-4062	.08	11/64	2-4077	.13				
#10	24	3/8	15/64	2-4063	.10	11/64	2-4078	.11				
#12	24	7/16	5/16	2-4100	.25							
1/4	20	7/16	5/16	2-4064	.15	13/64	2-4079	.18	1/2	3/8	2-4111	.59
5/16	18	1/2	11/32	2-4065	.19	1/4	2-4080	.23	9/16	7/16	2-4112	1.25
3/8	16	9/16	29/64	2-4066	.29	17/64	2-4081	.34	11/16	17/32	2-4113	1.96
7/16	14	5/8	15/32	2-4059	.39	19/64	2-4083	1.59	3/4	5/8	2-4515	3.97
1/2	13	3/4	19/32	2-4067	.75	5/16	2-4082	1.18	7/8	7/8	2-4114	2.99
9/16	12	7/8	5/8	2-4109	2.60	3/8	2-4116	4.70				
5/8	11	15/16	3/4	2-4068	1.29	3/8	2-4096	2.90				
3/4	10	1 1/8	7/8	2-4097	2.49	13/32	2-4166	8.90				
1	8	1 7/16	1 1/16	2-4135	5.75	9/16	2-4144	9.80				
- FINE THREAD -												
#10	32	3/8	15/64	2-4069	.11	11/64	2-4084	.11				
1/4	28	7/16	5/16	2-4070	.16	13/64	2-4085	.19				
5/16	24	1/2	11/32	2-4071	.21	1/4	2-4086	.25				
3/8	24	9/16	29/64	2-4072	.34	17/64	2-4087	.39				
7/16	20	5/8	15/32	2-4118	.48	19/64	2-4117	1.49				
1/2	20	3/4	19/32	2-4073	.79	5/16	2-4088	1.29				
9/16	18	7/8	5/8	2-4120	3.90	11/32	2-4098	4.70				
5/8	18	15/16	3/4	2-4074	1.49	3/8	2-4089	3.60				
3/4	16	1 1/8	7/8	2-4157	2.95	13/32	2-4119	9.49				
1	14	1 7/16	1 1/16	2-4145	13.95	9/16	2-4151	11.49				

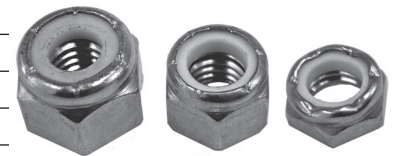

NYLON INSERT LOCK NUT SHOP ASSORTMENT: 1460 PIECES # 3-3037 \$ 275.50 #6 THRU 1/2"

## AIR CLEANER NUTS

\*POLISHED\*

SIZE	O.D.	PART #	\$
1/4-20	1"	2-4565	14.35
	1 1/4	2-4501	16.25
5/16-18	1"	2-4566	14.75
	1 1/4	2-4503	16.25.

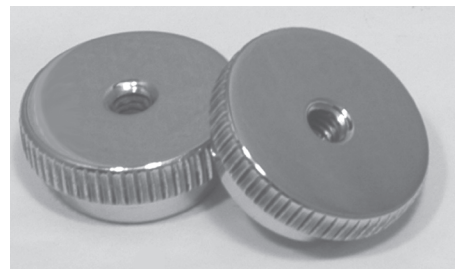

NOTE: MOST CARBS HAVE A 1/4-20 STUD

TOLL FREE ORDER LINE : 1-800-767-4781



# US WASHERS

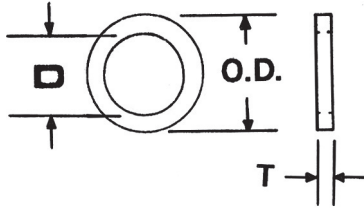

SIZE	NAME	I.D	O.D	T	PART#	\$
#4	MS803	.125	.250	.020	2-4260	.03
	MS804	.125	.310	.022	2-4224	.03
	#4 STAND	.125	.315	.020	2-4212	.03
	#4 AN	.125	.315	.023	2-4200	.03
	3MM SMALL	.132	.225	.016	1-2000	.03
	3MM STAND	.132	.275	.018	1-2008	.03
	3MM LARGE	.132	.345	.027	1-2016	.03
	#6	MS805	.156	.316	.030	2-4261
#6 STAND		.156	.375	.024	2-4213	.03
#6 FENDER		.156	.625	.030	2-4299	.06
MS806		.168	.375	.041	2-4225	.03
#8	#8 STAND	.172	.375	.025	2-4214	.03
	4MM SMALL	.175	.315	.019	1-2001	.05
	4MM STAND	.175	.350	.030	1-2009	.03
	4MM LARGE	.175	.465	.037	1-2017	.05
	#8 FENDER	.175	.75	.045	2-4286	.08
	#8 AN	.178	.375	.032	2-4202	.03
#10	MS807	.187	.375	.040	2-4226	.03
	#10 FENDER	.205	.687	.045	2-4236	.08
	#10 FENDER	.205	.75	.045	2-4717	.11
	#10 FENDER	.205	1.00	.045	2-4237	.13
	#10 AN	.207	.438	.060	2-4203	.03
	5MM SMALL	.215	.346	.035	1-2002	.05
	5MM STAND	.215	.390	.035	1-2010	.03
	5MM LARGE	.215	.590	.037	1-2018	.07
	MS808	.217	.438	.037	2-4262	.03
#12	#12 X .59	.22	.59	.037	2-4990	.97
	#12 FENDER	.22	1.00	.045	2-4991	1.10
	#12 STAND	.245	.50	.040	2-4216	.05
1/4	6MM SMALL	.255	.433	.055	1-2003	.05
	6MM STAND	.255	.475	.055	1-2011	.04
	MS809	.255	.560	.055	2-4227	.06
	6MM LARGE	.255	.70	.055	1-2019	.12
	1/4 HEAVY	.255	.75	.070	2-4277	.27
	1/4 AN	.265	.50	.060	2-4205	.04
	MS810	.280	.625	.062	2-4263	.05
	1/4 STAND	.285	.630	.040	2-4217	.05
	1/4 FENDER	.285	.688	.05	2-7497	.17
	1/4 FENDER	.285	1.00	.045	2-4238	.15
	1/4 FENDER	.285	1.25	.045	2-4239	.24
	1/4 FENDER	.285	1.50	.045	2-4240	.33

SIZE	NAME	I.D.	O.D.	T	PART#	\$
5/16	8MM CLEVIS	.312	.630	.079	1-2033	.18
	MS811	.320	.730	.055	2-4229	.09
	5/16 HEAVY	.325	.850	.085	2-4248	.38
	5/16 AN	.330	.565	.055	2-4206	.05
	8MM SMALL	.335	.578	.055	1-2004	.06
	8MM STAND	.335	.620	.055	1-2012	.06
	5/16 STAND	.340	.750	.050	2-4218	.06
	8MM LARGE	.340	.935	.075	1-2020	.25
	MS812	.345	.685	.055	2-4264	.06
	5/16 FENDER	.345	1.25	.050	2-4287	.24
5/16 FENDER	.345	1.50	.050	2-4241	.33	
3/8	MS813	.375	.875	.075	2-4230	.14
	3/8 SPL	.378	.720	.105	2-4786	.79
	INT/EXH	.380	1.25	.312	2-4425	4.50
	RKT INT	.380	1.35	.25	2-4428	9.50
	SBC INTAKE	.390	.675	.120	2-4211	.37
	3/8 HINGE	.390	1.00	.120	2-4245	.75
	EXTRA HEAVY	.390	1.50	.120	2-4249	5.99
	10MM CLEVIS	.394	.810	.098	1-2034	.29
	3/8 AN	.395	.630	.055	2-4207	.06
	MS814	.400	.815	.055	2-4265	.07
	3/8 FENDER	.400	1.50	.050	2-4242	.33
	3/8 STAND	.410	.875	.050	2-4219	.08
	10MM SMALL	.415	.695	.055	1-2005	.13
	10MM STAND	.415	.780	.075	1-2013	.13
	10MM LARGE	.420	1.17	.090	1-2021	.39
7/16	7/16 HEAVY	.438	1.17	.090	2-4423	2.39
	7/16 SPACER	.438	1.50	.050	2-4973	4.49
	EXTRA HVY	.438	1.50	.120	2-4492	7.99
	MS815	.440	1.00	.065	2-4231	.19
	ARP HEAD	.450	.810	.120	2-4417	3.50
	7/16 AN	.455	.750	.055	2-4208	.09
	MS816	.470	.920	.055	2-4266	.11
	12MM CLEVIS	.474	1.00	.120	1-2035	.39
	7/16 STAND	.495	1.12	.060	2-4220	.18
	1/2	1/2 SPL	.502	1.00	.120	2-4710
1/2 HEAVY		.502	1.17	.090	2-4940	1.39
1/2 SPACER		.502	1.50	.050	2-4994	4.49
EXTRA HEAVY		.502	1.50	.120	2-4907	5.89
12MM SMALL		.510	.815	.075	1-2006	.18
12MM STAND		.510	.945	.085	1-2014	.19
MS817		.510	1.26	.075	2-4232	.23
12MM LARGE		.510	1.42	.092	1-2022	.59
1/2 AN		.515	.875	.055	2-4209	.11
1/2 STAND		.530	1.26	.060	2-4221	.19
MS818		.540	1.06	.075	2-4267	.21
1/2 FENDER		.560	2.00	.06	2-4243	.59

SHOP ASSORTMENTS: 1705 PIECES #3-3009 \$ 155.00  
 2250 PIECES 3-3066 178.00

PERSONAL ASSORTMENT: 1200 PC. #3-3200 94.00

QUANTITY DISCOUNTS: 20% off of 100 of any one size of fastener, 30% off of 500, 36% of 1000. Call for quotes on larger quantities. Quantity discounts above the 100 piece level do not apply to all items.

# US WASHERS

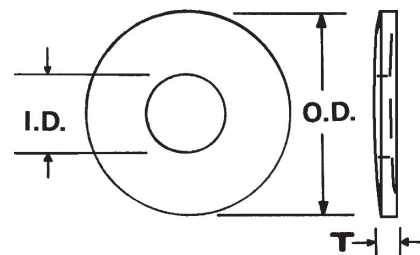
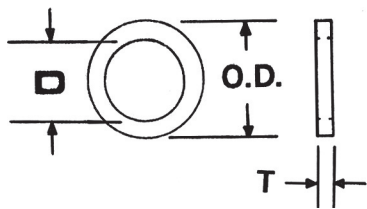

SIZE	NAME	I.D.	O.D.	T	PART#	\$
9/16	MS819	.57	1.37	.100	2-4233	.39
	9/16 STAND	.58	1.06	.07	2-7496	.29
	9/16 AN	.59	1.06	.060	2-4204	.19
	14MM STAND	.59	1.10	.100	1-2025	.29
	14MM LARGE	.59	1.73	.120	1-2026	.99
5/8	5/8 AN	.64	1.18	.060	2-4210	.29
	16MM SMALL	.68	1.08	.093	1-2007	.36
	16MM STAND	.68	1.17	.115	1-2015	.34
	MS820	.69	1.31	.08	2-4268	.32
	5/8 STAND	.69	1.55	.075	2-4222	.39
	16MM LARGE	.69	1.97	.115	1-2023	1.24
	MS821	.71	1.75	.120	2-4234	.85
3/4	3/4 AN	.78	1.31	.085	2-4235	.45
	3/4 STAND	.82	1.74	.105	2-4223	.50
	MS822	.83	1.50	.115	2-4228	.59
	20MM LARGE	.86	2.35	.16	1-2028	1.99
7/8	7/8 STAND	.94	2.00	.12	2-4439	.64
1	1" AN	1.03	1.75	.105	2-4409	.58
	MS826	1.06	1.97	.11	2-4275	.91
1 1/4	1 1/4" STAND	1.35	2.75	.12	2-4421	1.78

## WASHERS FOR BODY MOUNTS, SHOCKS, SUSPENSION BUSHINGS, ETC - LET US KNOW IF YOU WANT THEM DISHED -

SIZE	NAME	I.D.	O.D.	T	PART#	\$
3/8	SHOCK	.39	1.44	.120	2-4438	5.50
3/8	BODY MOUNT	.39	1.81	.120	2-4276	13.25
3/8	BODY MOUNT	.39	2.04	.120	2-4289	6.25
3/8	SWAY BAR	.41	1.17	.090	2-4713	5.50
7/16	STRIKER	.44	1.44	.120	2-4427	8.75
7/16	BODY MOUNT	.44	1.81	.120	2-4285	13.25
7/16	BODY MOUNT	.44	2.04	.120	2-4279	8.00
7/16	BODY MOUNT	.44	2.21	.105	2-4401	18.99
1/2	STRIKER	.50	1.44	.120	2-4479	8.50
1/2	BODY MOUNT	.50	1.81	.120	2-4402	13.25
1/2	BODY MOUNT	.50	2.04	.120	2-4403	11.50
1/2	BODY MOUNT	.50	2.21	.105	2-4288	19.50
9/16	BODY MOUNT	.57	2.21	.105	2-4406	19.50
5/8	5/8 HEAVY	.63	1.44	.120	2-4488	12.50
5/8	BODY MOUNT	.63	1.81	.120	2-4415	13.25
5/8	BODY MOUNT	.63	2.21	.105	2-4416	19.99

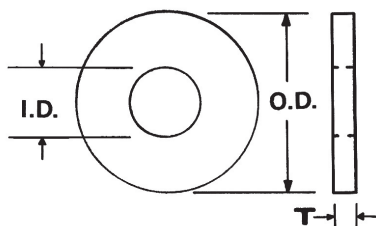

## HARMONIC BALANCER WASHERS

SIZE	FOR:	I.D.	O.D.	T	PART#	\$
7/16	SBC	.438	1.75	.31	2-4450	14.30
7/16	FORD MOD	.484	1.50	.25	2-4712	13.20
1/2	331/390 CAD	.502	1.39	.28	2-4464	13.45
1/2	AMC	.502	1.75	.30	2-4453	14.40
1/2	ROCKET	.502	1.75	.31	2-4490	14.45
1/2	BBC	.502	2.00	.31	2-4451	17.19
9/16	250 FORD ST6	.564	1.75	.25	2-4906	14.45
9/16	472/500 CAD	.564	2.00	.25	2-4471	16.30
5/8	PONTIAC	.630	1.62	.30	2-4473	15.10
5/8	215 BUICK	.630	1.75	.30	2-4474	14.40
5/8	SBF	.630	1.75	.19	2-4472	14.10
5/8	FE/BBF	.630	2.00	.31	2-4468	18.00
3/4	455 BUICK	.755	1.69	.38	2-4487	17.20
3/4	260/455 OLDS	.755	1.87	.32	2-4979	18.10
3/4	EARLY HEMI	.755	2.00	.25	2-4980	17.30
3/4	BBM/426 HEMI	.755	1.75	.38	2-4996	15.40

## HEAD BOLT WASHERS HARDENED 17-4 PH

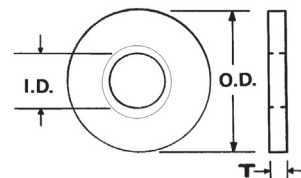

ID	OD	T	PART #	\$
7/16	.810	.120	2-4417	3.50
1/2	.870	.150	2-4215	5.50
9/16	1.00	.180	2-4486	6.25

## D SHAPED WASHERS

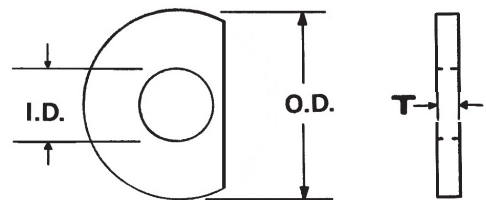

ID	OD	T	PART #	\$
1/4	1 1/4	.045	2-4426	2.89
3/8	1 3/16	.09	2-4418	2.98
7/16	1 3/16	.09	2-4410	3.49
9/16	1 3/8	.10	2-4998	3.68

**TOLL FREE ORDER LINE : 1-800-767-4781**

# SPACERS - MADE IN USA

## 3/8" I.D. X .54 O.D.

### SWAY BAR SPACERS

WE USE THESE IN OUR SUSPENSION KITS

LENGTH	PART#	\$
9/16	2-4459	4.00
11/16	2-6203	4.10
15/16	2-6201	4.17
1	2-6280	4.19
1 1/4	2-6209	4.62
1 1/2	2-4575	4.73
1 3/4	2-4576	4.83
2	2-4504	4.94
2 1/4	2-4505	5.00
2 1/2	2-4506	5.15
2 3/4	2-4507	5.46
3	2-4508	5.78
3 1/4	2-4510	6.00
3 1/2	2-4577	6.29
4	2-6284	6.83
4 1/2	2-6285	7.77
5	2-6286	8.38
5 1/2	2-6283	8.86
6	2-6288	9.42
6 1/2	2-6289	9.96
6 7/8	2-4597	10.40

## 5/8" O.D. ACCESSORY SPACERS

SIZE:	1/4 ID		5/16 ID		3/8 ID	
LENGTH	PART#	\$	PART#	\$	PART#	\$
1/4	2-4720	5.20	2-4730	5.22	2-4483	5.24
3/8	2-4721	5.73	2-4731	6.74	2-4741	6.76
1/2	2-4722	6.23	2-4434	7.18	2-4742	7.22
5/8	2-4723	6.78	2-4733	7.60	2-4743	7.64
3/4	2-4724	7.26	2-4734	7.92	2-4744	7.96
1	2-4726	8.28	2-4736	8.30	2-4746	8.39
1 1/4	2-6211	9.31	2-6213	9.39	2-6215	9.44
1 1/2			2-6214	10.45	2-6216	10.49

## 3/4" O.D. ACCESSORY SPACERS

JUST THE TRICK FOR ALIGNING BRACKETS ON YOUR STREET ROD!

SIZE:	1/4 ID		5/16 ID		3/8 ID		7/16 ID		1/2 ID	
LENGTH	PART#	\$	PART#	\$	PART#	\$	PART#	\$	PART#	\$
1/4	2-4430	6.18	2-4443	6.22	2-4440	6.24	2-4446	6.27	2-4452	6.29
3/8	2-4728	6.85	2-4748	6.88	2-4752	6.90	2-4758	6.91	2-4765	6.92
1/2	2-4431	7.23	2-4444	7.27	2-4441	7.29	2-4447	7.32	2-4766	7.34
5/8	2-4729	7.85	2-4749	7.89	2-4753	7.92	2-4759	7.95	2-4462	7.97
3/4	2-4738	8.28	2-4463	8.32	2-4754	8.34	2-4760	8.37	2-4454	8.39
1	2-4432	9.33	2-4445	9.19	2-4442	9.39	2-4448	9.42	2-4455	9.44
1 1/4	2-4739	10.38	2-4750	10.42	2-4755	10.44	2-4761	10.47	2-4767	10.40
1 1/2			2-6218	11.47	2-4756	11.49	2-4762	11.52	2-4768	11.54

## 1" O.D. SPACERS

SIZE:	7/16 ID		1/2 ID		9/16 ID		5/8 ID	
LENGTH	PART#	\$	PART#	\$	PART#	\$	PART#	\$
1/4	2-4770	8.18	2-4711	8.39	2-4784	8.86	2-6208	9.44
3/8	2-6219	9.12	2-6221	9.41	2-6223	9.73	2-6287	10.10
1/2	2-4771	9.44	2-4778	9.81	2-4785	10.16	2-6210	10.70
5/8	2-4772	10.00	2-4779	10.42	2-6270	10.87	2-6273	11.20
3/4	2-4773	10.66	2-4780	10.98	2-4787	11.33	2-6212	11.91
1	2-4774	11.84	2-4781	12.27	2-6271	12.59	2-6274	13.11
1 1/4	2-4775	12.99	2-4782	13.42	2-6272	13.88	2-6275	14.35
1 1/2	2-4776	14.21	2-4783	14.58	2-4719	15.16	2-6276	15.57
2	2-6220	15.42	2-6222	15.74	2-6224	16.37	2-6277	16.79



## 1 1/4" O.D. SPACERS

SIZE:	7/16 ID		1/2 ID		9/16 ID		5/8 ID		3/4 ID	
LENGTH			PART#	\$			PART#	\$	PART#	\$
1/4	2-4929	10.38	2-4900	10.96	2-6232	11.50	2-4908	12.05	2-4916	12.58
3/8	2-6225	11.10	2-4922	11.50	2-6233	12.20	2-4924	12.59	2-4926	13.29
1/2	2-6226	11.80	2-4458	12.00	2-6234	12.92	2-4909	13.43	2-4481	13.99
5/8	2-4923	12.48	2-4460	12.83	2-6235	13.62	2-4925	14.10	2-4927	14.69
3/4	2-6227	13.20	2-4901	13.64	2-6236	14.31	2-4910	14.69	2-4917	15.39
1	2-6228	14.60	2-4902	15.17	2-6237	15.71	2-4911	16.25	2-4918	16.79
1 1/4	2-6229	15.99	2-4903	16.57	2-6238	17.10	2-4912	17.65	2-4919	18.19
1 1/2	2-6230	17.39	2-4904	17.97	2-6239	18.50	2-4461	19.10	2-4920	19.58
2	2-6231	18.78	2-4905	19.36	2-6240	19.90	2-4913	20.44	2-4921	20.98

**MADE IN USA:**  
**WE MAKE THESE IN**  
**OUR SHOP FROM 300**  
**SERIES STAINLESS**



# SPACERS - MADE IN USA

## 1 1/2" O.D. SPACERS

SIZE:	1/2 ID		9/16		5/8 ID		3/4 ID	
LENGTH	PART#	\$	PART#	\$	PART#	\$	PART#	\$
1/4	2-4477	12.58	2-4936	12.94	2-4951	13.28	2-4938	13.63
3/8	2-6290	13.89	2-6254	14.23	2-4952	14.66	2-4939	15.11
1/2	2-6247	15.20	2-6255	15.68	2-4953	16.00	2-4942	16.62
3/4	2-6248	17.23	2-6256	18.42	2-4954	18.89	2-4943	19.59
7/8	2-6249	19.39	2-6291	19.71	2-4931	20.43	2-4944	20.99
1	2-6250	20.96	2-6257	20.99	2-4933	21.83	2-4945	22.56
1 1/4	2-6251	23.10	2-6258	23.90	2-4934	24.71	2-4946	25.54
1 1/2	2-6252	25.70	2-6259	26.64	2-4935	27.57	2-4948	27.80
2	2-6253	28.32	2-6260	29.38	2-4937	30.43	2-4947	31.48

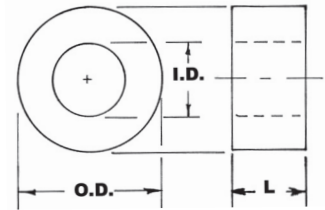

WE CUSTOM MAKE BUSHINGS & WASHERS UP TO 2" O.D - ANY LENGTH (THICKNESS) & INSIDE DIAMETER, DETERMINE THE ID, OD & THICKNESS AND GIVE US A CALL!

## 2" O.D. SPACERS

SIZE:	1/2 ID		9/16 ID		5/8 ID		3/4	
LENGTH	PART#	\$	PART#	\$	PART#	\$	PART#	\$
1/4	2-6293	13.32	2-4471	13.44	2-4970	13.97	2-4980	14.49
5/16	2-4451	14.37	2-4961	14.60	2-4468	15.22	2-6296	15.85
3/8	2-4949	15.42	2-4962	15.75	2-4971	16.59	2-4982	16.91
1/2	2-4950	17.52	2-4963	17.73	2-4972	18.33	2-4983	18.36
5/8	2-4955	19.62	2-4964	19.94	2-4974	20.57	2-4984	20.96
3/4	2-4956	21.72	2-4965	22.21	2-4975	22.81	2-4985	23.10
1	2-4957	25.92	2-4966	26.59	2-4976	27.29	2-4986	27.81
1 1/4	2-4958	30.12	2-4967	30.94	2-4977	31.87	2-4987	32.54
1 1/2	2-4959	34.32	2-4968	35.31	2-4978	36.35	2-4988	37.26
2	2-4960	38.52	2-4969	39.68	2-6294	40.83	2-4989	41.99

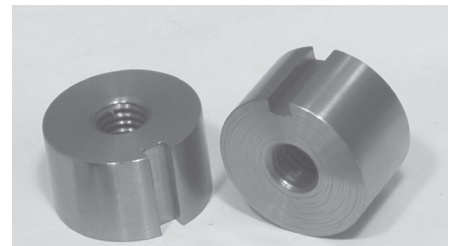

**TAILGATE MOUNT BUSHINGS FOR 1954-87 CHEVY STEPSIDE TRUCKS**

2-4704 \$15.65 EACH

USED WITH 7/16-14 X 1 BOLTS

# SPECIALTY WASHERS - MADE IN USA

**CORE SUPPORT BODY MOUNT WASHER FOR 1960-72 CHEVY TRUCKS & 1960-64 CARS**

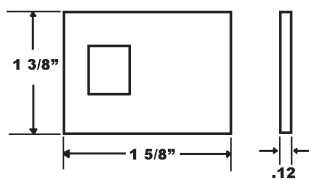

# 2-4400 \$ 17.99

**BED MOUNT WASHERS FOR CHEVY TRUCKS**

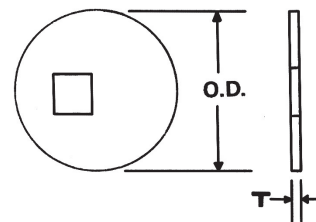

SIZE	NAME	O.D.	T	PART#	\$
3/8	PRE 1973	1.50	.12	2-4246	5.85
1/2	73 & UP	1.82	.12	2-4247	7.85

**WASHER FOR C4 CORVETTE REAR SUSPENSION**

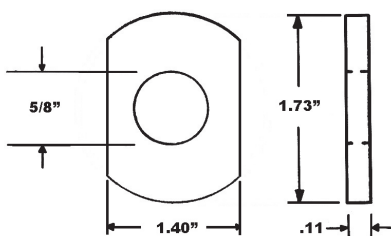

# 2-4475 \$ 4.30

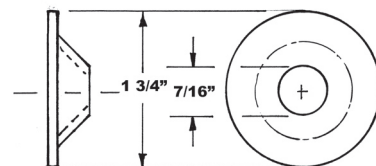

**BED MOUNT WASHER FOR FORD TRUCKS**  
NOTE ID SHOWS 7/16 - BUT 1/2" FLAT SOCKETS WILL FIT - SEE PAGE 102

# 2-4408 \$ 12.50

# SPECIALTY WASHERS

## RUBBER BACKED WASHERS

GREAT FOR SEALING BOLTS ON  
CENTER BOLT VALVE COVERS  
OR FOR PROTECTING  
DELICATE PAINT

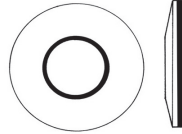

SIZE	O.D.	PART#	\$
#10	1/2	2-4489	.12
1/4	5/8	2-4465	.15
5/16	3/4	2-4466	.24
3/8	7/8	2-4467	.29
1/2	1	2-4469	.46

## COUNTERSUNK WASHERS (DIMPLE WASHERS)

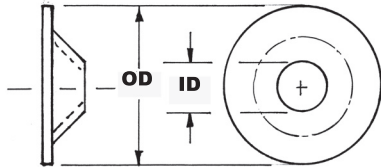

USED ON LATE 1920'S & EARLY 1930'S DOOR  
HINGES - USUALLY WITH SLOTTED OVAL  
JACKSON HEAD SCREWS - SEE PG 112/114

I.D.	O.D.	PART #	\$
#10	5/8	2-4790	.29
#10	3/4	2-4715	.39
#12	5/8	2-4791	.32
#12	3/4	2-4716	.39
1/4*	11/16	2-4794	.38
1/4**	11/16	2-4792	.38
1/4	1	2-4797	.42
5/16**	3/4	2-4795	.49
5/16	1	2-4793	.42
5/16	1 1/4	2-4798	.49

\* FOR SCREWS WITH UNDERSIZED (#10) HEADS ONLY

\*\* FOR SCREWS WITH UNDERSIZED (#12) HEADS ONLY

## TRIM WASHERS

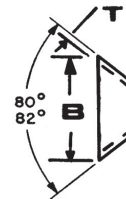
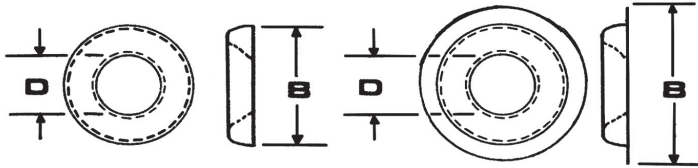

**NOTE:**  
ORDER BY  
HEAD SIZE, NOT  
SCREW SIZE

BOLT SIZE D	FINISHING (CUP)			FLANGED (CUP)		
	B	PART#	\$	B	PART#	\$
#4	.375	2-4256	.03			
#6	.40	2-4250	.03	.50	2-4280	.06
#8	.515	2-4251	.04	.60	2-4281	.07
#10	.600	2-4252	.05	.70	2-4282	.08
#12	.697	2-4253	.08			
1/4	.785	2-4254	.11			
5/16	.885	2-4255	.15			

SCREW HEAD	COUNTERSUNK FLAT			
	B	T	PART#	\$
#4	1/4	.02	2-4269	.15
#6	5/16	.03	2-4270	.16
#8	3/8	.03	2-4271	.16
#10	7/16	.03	2-4272	.17
#12	1/2	.03	2-4273	.17
1/4	9/16	.04	2-4274	.19
5/16	23/32	.04	2-4491	.20

## STAINLESS ALIGNMENT SHIMS \* MADE IN AUSTRALIA\*

AVAILABLE IN (3) THICKNESSES:

THICKNESS	PART#	\$
1/32	2-4497	2.00
1/16	2-4498	2.25
1/8	2-4499	2.75

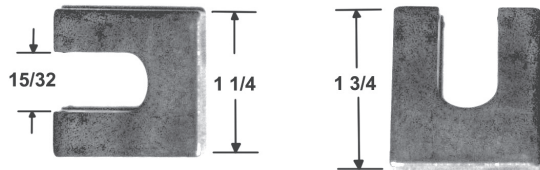

## CURVED LOCK WASHERS - OFTEN USED WITH SHOULDER BOLTS (CONVERTIBLE TOPS, ETC)



SIZE	A	B	T	PART #	\$
#10	.22	.38	.02	1-2109	.06
1/4	.26	.48	.02	1-2110	.07
5/16	.33	.59	.02	1-2111	.12
3/8	.39	.62	.03	2-4360	.39
7/16	.46	.75	.03	2-4369	.44
1/2	.52	.87	.03	2-4361	.49

# US LOCK WASHERS

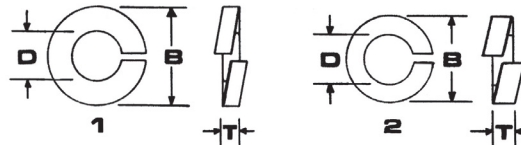

BOLT SIZE D	STANDARD SPLIT LOCK				HIGH COLLAR LOCK (FOR SOCKET HEAD BOLTS)			
	B1	T1	PART#	\$	B2	T2	PART#	\$
#4	.212	.025	2-4300	.04				
#6	.212	.031	2-4301	.04				
#8	.296	.040	2-4302	.04	.26	.05	2-4356	.03
#10	.337	.047	2-4303	.04	.29	.05	2-4314	.05
#12	.380	.056	2-4304	.05				
1/4	.493	.062	2-4305	.06	.36	.08	2-4316	.10
5/16	.591	.078	2-4306	.11	.45	.095	2-4317	.19
3/8	.688	.094	2-4307	.14	.56	.125	2-4318	.25
7/16	.784	.109	2-4308	.21				
1/2	.879	.125	2-4309	.27	.73	.175	2-4320	.50
9/16	.971	.141	2-4312	.39				
5/8	1.09	.156	2-4310	.60	.90	.21	2-4321	.75
3/4	1.25	.187	2-4313	.85				
7/8	1.43	.235	2-4315	1.35				

LOCK WASHER SHOP  
ASSORTMENT: 3105  
PIECES INTERNAL,  
EXTERNAL, SPLIT &  
C' SUNK EXTERNAL  
# 3-3078 \$ 197.00

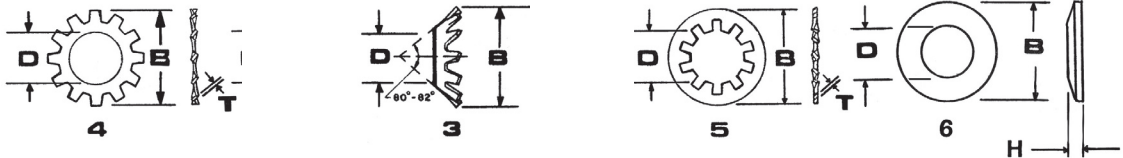

BOLT SIZE D	EXTERNAL TOOTH				COUNTERSUNK EXT. TOOTH (FOR FLAT HEAD BOLTS)			INTERNAL TOOTH				CONICAL				
	B5	T5	PART#	\$	B6	PART#	\$	B7	T7	PART#	\$	B8	H	T8	PART#	\$
#4	.253	.017	2-4331	.04				.270	.015	2-4343	.04					
#6	.320	.019	2-4332	.04	.301	2-4323	.13	.295	.017	2-4344	.04					
#8	.381	.021	2-4333	.04	.340	2-4324	.14	.340	.018	2-4345	.04					
#10	.410	.023	2-4334	.04	.369	2-4325	.15	.381	.020	2-4346	.04	.437	.048	.025	2-4363	.19
#12	.475	.026	2-4335	.07	.421	2-4326	.22	.410	.020	2-4347	.08					
1/4	.510	.026	2-4336	.05	.468	2-4327	.23	.478	.023	2-4348	.05	.500	.062	.030	2-4365	.21
5/16	.610	.028	2-4337	.06	.614	2-4328	.35	.610	.028	2-4349	.06	.625	.078	.040	2-4366	.24
3/8	.694	.032	2-4338	.09	.765	2-4329	.37	.692	.032	2-4350	.10	.750	.100	.050	2-4367	.29
7/16	.770	.032	2-4339	.16				.789	.032	2-4351	.16					
1/2	.900	.037	2-4340	.18				.900	.037	2-4352	.18					
5/8	1.07	.042	2-4341	.30				1.07	.042	2-4353	.30					
3/4	1.24	.051	2-4342	.40				1.23	.044	2-4354	.40					

## VIBRATION PROOF LOCK WASHERS - HARDENED - 316 SS -

T	SIZE	O.D.	PART#	\$	T	SIZE	O.D.	PART#	\$
.06	# 10	.35 (8.9MM)	2-4371	1.52	.10	3/8 (10.4MM)	.62 (16MM)	2-4377	2.99
.09	1/4	.45 (11.4MM)	2-4374	1.85	.12	3/8 (10.4MM)	.83 (20.8MM)	2-4396	5.20
.10	1/4	.53 (13.5MM)	2-4394	1.95	.11	7/16 (11MM)	.73 (18.5MM)	2-4378	3.87
.10	5/16 (8MM)	.53 (13.5MM)	2-4375	2.31	.11	1/2 (12MM)	.77 (19.5MM)	2-4379	3.94
.12	5/16 (8MM)*	.65 (16.5MM)	2-4395	2.73	.13	9/16 (14MM)	.91 (23.1MM)	2-4380	5.51
					.14	5/8 (16MM)	1.0 (25.4MM)	2-4381	5.51

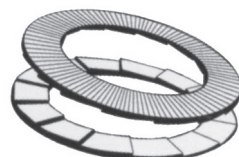

**NOTE:** (2) PAIRS ARE NEEDED WHEN THE BOLT IS USED WITH A NUT - (1) FOR UNDER THE BOLT & (1) FOR UNDER THE NUT - WILL NOT WORK WITH FLAT WASHERS!

# FLAT HEAD SHEET METAL SCREWS

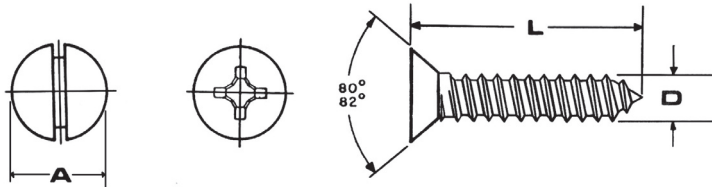

**DIMENSION TABLE (INCHES)**

D	DIAMETER	.112	.138	.164	.190	.216	.242
A	HEAD DIA.	.21	.25	.30	.35	.42	.45
	ISO#	4	6	8	10	12	14

**SLOTTED FLAT SHEET METAL SCREW ASSORTMENTS: SHOP**  
 1210 PIECES # 3-3044 \$ 317.75  
**PERSONAL: 1000 PIECES 3-3177**  
 154.00

**SLOTTED PART NUMBER AND PRICE GUIDE**

ISO#	4		6		8		10		12		14	
LENGTH	PART#	\$	PART#	\$	PART#	\$	PART#	\$	PART#	\$	PART#	\$
1/4	2-1105	.07										
3/8	2-1100	.07	2-1106	.08	2-1142	.11	2-9944	.15				
1/2	2-1101	.08	2-1107	.09	2-1114	.12	2-1121	.16	2-1128	.25		
5/8	2-1102	.08	2-1108	.10	2-1115	.13	2-1122	.17	2-1129	.26		
3/4	2-1103	.09	2-1109	.11	2-1116	.14	2-1123	.18	2-1130	.27	2-1136	.38
1	2-1104	.10	2-1110	.12	2-1117	.15	2-1124	.20	2-1131	.30	2-1137	.43
1 1/4			2-1111	.13	2-1118	.16	2-1125	.22	2-1132	.32	2-1138	.49
1 1/2			2-1112	.14	2-1119	.18	2-1126	.24	2-1133	.34	2-1139	.69
1 3/4							2-1145	.26	2-1135	.36		
2			2-1113	.17	2-1120	.21	2-1127	.27	2-1134	.39	2-1140	.98
2 1/2							2-1146	.36	2-9946	.47		
3					2-1143	.29	2-1147	.45	2-9947	.58		

**PHILLIPS PART NUMBER AND PRICE GUIDE**

ISO#	4		5		6		8		10		12		14	
LENGTH	PART#	\$	PART#	\$	PART#	\$	PART#	\$	PART#	\$	PART#	\$	PART#	\$
1/4	2-1155	.03			2-9940	.04								
3/8	2-1150	.04			2-1156	.05	2-1163	.06	2-9953	.08				
1/2	2-1151	.05	2-1149	.09	2-1157	.05	2-1164	.07	2-1171	.09	2-9956	.11		
5/8	2-1152	.06			2-1158	.06	2-1165	.08	2-1172	.11	2-9957	.12	2-9960	.19
3/4	2-1153	.06			2-1159	.07	2-1166	.09	2-1173	.12	2-1180	.13	2-1186	.23
1	2-1154	.07			2-1160	.08	2-1167	.10	2-1174	.14	2-1181	.16	2-1187	.25
1 1/4					2-1161	.09	2-1168	.11	2-1175	.16	2-1185	.18	2-1199	.27
1 1/2					2-1162	.10	2-1169	.12	2-1176	.18	2-1183	.20	2-1189	.28
1 3/4							2-1179	.14	2-9954	.19	2-9958	.23	2-9961	.30
2							2-1144	.15	2-1177	.21	2-1184	.25	2-1190	.32
2 1/2							2-1170	.18	2-1145	.24	2-9959	.29	2-9962	.35
3							2-9952	.29	2-9955	.32	2-1182	.36	2-1188	.39
4													2-1198	.85

**PHILLIPS FLAT SHEET METAL SCREW SHOP ASSORTMENT: 1210 PIECES 3-3025 184.00**  
**PERSONAL ASSORTMENT: 1000 PIECES 3-3176 113.00**

# SQUARE DRIVE DECK SCREWS

SIZE	LENGTH	PART#	\$
#8	1 5/8	2-1194	.18
#8	2	2-1191	.19
#10	2 1/2	2-1192	.27
#10	3	2-1193	.32
#10	4	2-1195	.36

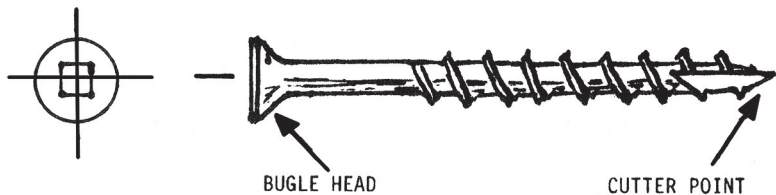

BUGLE HEAD

CUTTER POINT



# HEX HEAD SHEET METAL SCREWS

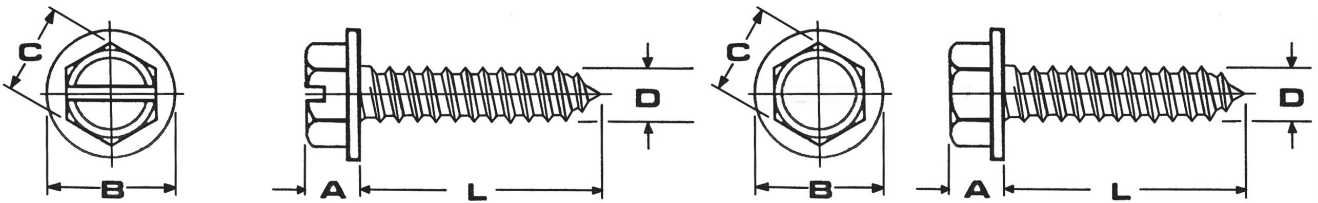

DIMENSION TABLE (INCHES)

D	DIAMETER	.138	.164	.190	.216	.242	.312
A	HEAD HT.	.079	.141	.151	.194	.240	.280
B	HEAD DIA.	.32	.34	.40	.42	.50	.65
C	WRENCH	1/4	1/4	5/16	5/16	3/8	1/2
	SIZE	6	8	10	12	14	5/16



## SLOTTED & UNSLOTTED PART NUMBER AND PRICE GUIDE

SIZE	6		8		8		10		10		12		14		14		5/16	
LENGTH	PART#	\$	PART#	\$	UNSLOTTED	PART#	\$	UNSLOTTED	PART#	\$	PART#	\$	PART#	\$	UNSLOTTED	PART#	\$	UNSLOTTED
1/4	2-1000	.08																
3/8	2-1001	.09	2-1008	.09	PART #	\$	2-1018	.10	PART#	\$					PART#	\$	PART#	\$
1/2	2-1002	.10	2-1009	.11	2-1049	.15	2-1019	.12	2-1026	.29	2-1029	.19	2-1039	.24	2-1084	.74		
5/8	2-1003	.12	2-1010	.12			2-1020	.13	2-1077	.32	2-1030	.20	2-1040	.26	2-1080	.79		
3/4	2-1004	.14	2-1011	.12	2-1059	.17	2-1021	.14	2-1078	.35	2-1031	.21	2-1041	.27	2-1081	.81	2-1086	1.26
7/8			2-1012	.14			2-1022	.16			2-1032	.22	2-1042	.29				
1			2-1013	.15	2-1075	.19	2-1023	.17	2-1079	.39	2-1033	.22	2-1043	.32	2-1082	.89	2-1087	1.29
1 1/4			2-1014	.17			2-1024	.22			2-1034	.25	2-1044	.35			2-1088	1.49
1 1/2			2-1015	.19			2-1025	.25			2-1035	.27	2-1045	.39	2-1090	.99		
1 3/4											2-1036	.29	2-1046	.41				
2											2-1037	.30	2-1047	.45				
3													2-1048	.59				

SLOTTED HEX SHEET METAL SCREW SHOP ASSORTMENT: 1000 PIECES # 3-3036 \$ 255.50

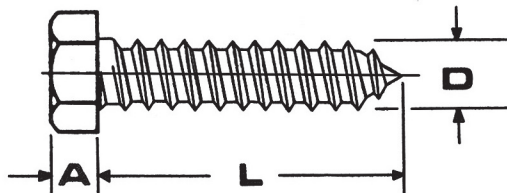
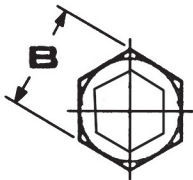

PLAIN INDENTED HEX DIMENSION TABLE (INCHES)

D	DIAMETER	.138	.164	.190	.216	.242	.312
A	HEAD HT.		.103	.112	.147	.156	.220
B	WRENCH	1/4	1/4	5/16	5/16	3/8	1/2
	SIZE	6	8	10	12	14	5/16

## PLAIN INDENTED HEX PART NUMBER AND PRICE GUIDE

SIZE	6		8		10		12		14 (3/8 HEAD)		14 (7/16 HEAD)		5/16	
LENGTH	PART#	\$	PART#	\$	PART#	\$	PART#	\$	PART#	\$	PART#	\$	PART#	\$
3/8	2-1066	.15	2-1083	.16										
1/2			2-1050	.17	2-1053	.19	2-1056	.25						
5/8	2-1073	.16	2-1063	.18	2-1064	.22			2-1062	.39				
3/4			2-1051	.19	2-1054	.25	2-1057	.29	2-1060	.46				
1			2-1052	.22	2-1055	.29	2-1058	.33	2-1061	.49	2-1072	.65	2-1092	.99
1 1/4									2-1068	.54				
1 1/2									2-1070	.80				
2									2-1071	.99				

# OVAL HEAD SHEET METAL SCREWS

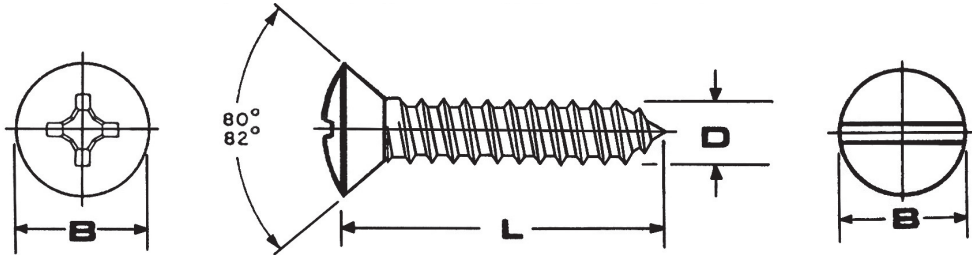

**DIMENSION TABLE (INCHES)**

D	DIAMETER	.112	.138	.164	.190	.216	.242
B	HEAD DIA.	.21	.26	.31	.36	.41	.45
	ISO#	4	6	8	10	12	14

**PHILLIPS PART NUMBER & PRICES SLOTTED PART NUMBER & PRICES**

SIZE	4		6		8		10		12		14	
LENGTH	PART#	\$	PART#	\$	PART#	\$	PART#	\$	PART#	\$	PART#	\$
1/4	2-6450	.06	2-6452	.08								
3/8	2-1449	.07	2-1457	.09	2-1496	.11	2-6453	.17				
1/2	2-1451	.08	2-1458	.09	2-1497	.13	2-1472	.18	2-6458	.21	2-6464	.26
5/8	2-1452	.09	2-1459	.10	2-1498	.14	2-1475	.19	2-6459	.22		
3/4	2-1453	.09	2-1456	.11	2-1471	.15	2-1476	.20	2-6460	.24	2-1488	.29
1	2-1462	.09	2-1465	.12	2-1470	.16	2-1473	.21	2-1487	.26	2-1489	.31
1 1/4			2-1454	.13	2-1469	.18	2-1478	.22	2-1482	.31	2-1490	.34
1 1/2			2-1463	.14	2-1499	.20	2-1479	.24	2-1494	.31	2-1491	.38
1 3/4					2-6454	.21	2-6456	.25	2-6461	.32	2-6465	.42
2					2-1474	.22	2-1480	.26	2-1493	.33	2-1492	.44
2 1/2					2-6455	.29	2-6457	.34	2-6462	.44	2-6466	.49
3									2-6463	.49		

**SLOTTED OVAL SHEET METAL SHOP ASSORTMENT:**  
1210 PIECES  
# 3-3039 \$330.75  
**PERSONAL ASSORTMENT:**  
1000 PIECES  
# 3-3163 \$190.00



SIZE	4		6		8		10		12		14	
LENGTH	PART#	\$	PART#	\$	PART#	\$	PART#	\$	PART#	\$	PART#	\$
1/4	2-6400	.04	2-6402	.04								
3/8	2-1400	.04	2-1407	.05	2-1415	.06	2-6404	.08				
1/2	2-1401	.04	2-1408	.05	2-1416	.07	2-1424	.09	2-1437	.12	2-6409	.17
5/8	2-1402	.06	2-1409	.06	2-1417	.08	2-1425	.11	2-6406	.14		
3/4	2-1403	.06	2-1410	.07	2-1418	.09	2-1426	.13	2-1432	.16	2-1438	.19
7/8					2-1443	.10						
1	2-1404	.06	2-1411	.08	2-1419	.11	2-1427	.15	2-1433	.19	2-1439	.22
1 1/4			2-1412	.09	2-1420	.12	2-1428	.17	2-1434	.21	2-1440	.25
1 1/2			2-1413	.10	2-1421	.14	2-1429	.19	2-1435	.22	2-1441	.29
1 3/4					2-6403	.16	2-6405	.20	2-6407	.25	2-6410	.32
2					2-1422	.17	2-1430	.22	2-1436	.29	2-1442	.34
2 1/2					2-1405	.20	2-1431	.25	2-1445	.33		
3					2-1447	.24	2-1423	.30	2-6408	.39	2-1446	.45

**PHILLIPS OVAL SHEET METAL SHOP ASSORTMENT:**  
1210 PIECES  
#3-3007 \$225.50  
**PERSONAL ASSORTMENT:**  
1000 PIECES  
#3-3159 \$112.75



**PHILLIPS OVAL JACKSONS**

SIZE:	8		10	
LENGTH	PART#	\$	PART#	\$
1/2	2-1481	.24		
5/8	2-1464	.27	2-1484	.44
3/4	2-1460	.29	2-1485	.49
1	2-1466	.34	2-1461	.54
1 1/4	2-1467	.39	2-1486	.59
1 1/2	2-1468	.44	2-1444	.64
1 3/4	2-1406	.49	2-1448	.69
2	2-1414	.54	2-1450	.74
2 1/2			2-1455	.89
3			2-1495	1.09

## JACKSON (UNDERSIZED) HEAD TRIM SCREWS

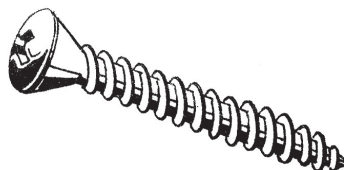

JACKSON HEAD		
D	.164	.190
B	.26	.31
ISO#	8	10

**NEED SLOTTED TRIM SCREWS?  
WE CAN TURN THE HEADS DOWN  
ON ANY OF OUR SLOTTED SCREWS:**

**ADD .80 TO THE COST OF A #8 SCREW  
1.10 TO A #10, 1.20 TO A #12, 1.30 TO  
THE COST OF A #14**

**PHILLIPS OVAL SHEET METAL SCREWS WITH JACKSON HEAD SCREWS  
SHOP ASSORTMENT: 1540 PIECES # 3-3040 \$330.50  
PERSONAL ASSORTMENT: 1000 PIECES 3-3161 214.00**

# PAN HEAD SHEET METAL SCREWS

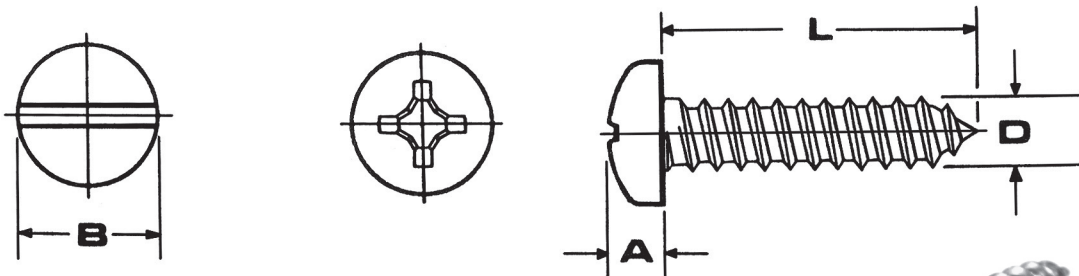

**DIMENSION TABLE (INCHES)**

D	DIAMETER	.112	.138	.164	.190	.216	.242
A	HEAD HT.	.068	.082	.096	.110	.125	.144
B	HEAD DIA.	.22	.26	.32	.37	.42	.47
	ISO#	4	6	8	10	12	14

**ADDITIONAL SIZE:  
#2 X 3/8" SLOTTED  
#2-1200 \$ .06**



**SLOTTED PART NUMBER AND PRICE GUIDE**

SIZE:	4		6		8		10		12		14	
LENGTH	PART#	\$	PART#	\$	PART#	\$	PART#	\$	PART#	\$	PART#	\$
1/4	2-1214	.06	2-1222	.08	2-1225	.12						
3/8	2-1201	.07	2-1207	.09	2-1216	.13	2-1228	.18				
1/2	2-1202	.07	2-1208	.09	2-1217	.13	2-1229	.19	2-1236	.24	2-1243	.32
5/8	2-1215	.08	2-1209	.10	2-1218	.14	2-1230	.20	2-1237	.26	2-1244	.33
3/4	2-1204	.09	2-1210	.11	2-1219	.15	2-1231	.21	2-1238	.28	2-1245	.34
1	2-1205	.10	2-1211	.12	2-1220	.16	2-1232	.23	2-1235	.32	2-1246	.37
1 1/4			2-1223	.14	2-1226	.17	2-1233	.24	2-1240	.35	2-1247	.39
1 1/2			2-1224	.16	2-1221	.17	2-1234	.25	2-1241	.39	2-1248	.46
2							2-1227	.29	2-1242	.48		

**PHILLIPS PART NUMBER AND PRICE GUIDE**

SIZE:	4		5		6		8		10		12		14	
LENGTH	PART#	\$	PART#	\$	PART#	\$	PART#	\$	PART#	\$	PART#	\$	PART#	\$
1/4	2-1250	.04			2-1258	.06	2-1268	.06	2-1329	.08				
3/8	2-1251	.04			2-1259	.07	2-1269	.07	2-1280	.09				
1/2	2-1252	.05	2-1212	.26	2-1260	.08	2-1270	.08	2-1281	.10	2-1291	.15	2-1301	.19
5/8	2-1253	.05			2-1261	.09	2-1271	.09	2-1282	.11	2-1292	.18	2-1302	.23
3/4	2-1254	.05			2-1262	.10	2-1272	.10	2-1283	.12	2-1293	.19	2-1303	.25
1	2-1255	.06			2-1263	.11	2-1273	.11	2-1284	.13	2-1294	.21	2-1304	.29
1 1/4	2-1256	.13			2-1264	.12	2-1274	.12	2-1285	.20	2-1295	.22	2-1305	.39
1 1/2	2-1257	.17			2-1265	.13	2-1275	.13	2-1286	.22	2-1296	.24	2-1306	.42
1 3/4					2-1266	.18	2-1276	.16	2-1287	.24	2-1297	.26	2-1311	.44
2					2-1267	.19	2-1277	.19	2-1288	.26	2-1298	.29	2-1308	.49
2 1/2							2-1278	.26	2-1289	.28	2-1299	.35	2-1309	.54
3							2-1279	.29	2-1290	.30	2-1300	.43	2-1310	.59

#12 x 1 JACKSON HEAD (.36/.37 HEAD DIAMETER): 2-1326 \$2.25 EACH

**SLOTTED PAN SHEET METAL SCREW SHOP ASSORTMENT: 1210 PIECES # 3-3043 \$ 319.50**  
**PERSONAL ASSORTMENT: 1000 PIECES 3-3179 180.00**  
**PHILLIPS PAN SHEET METAL SCREW SHOP ASSORTMENT: 1210 PIECES 3-3006 233.50**  
**PERSONAL ASSORTMENT: 1000 PIECES 3-3178 113.00**



**TOLL FREE ORDER LINE : 1-800-767-4781**

# ROUND HEAD SHEET METAL SCREWS

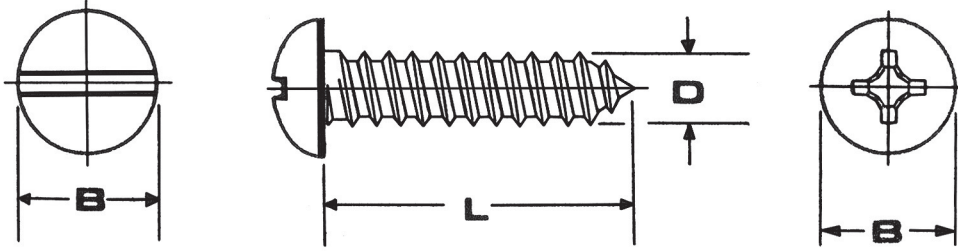

DIMENSION TABLE (INCHES)

D	DIAMETER	.112	.138	.164	.190	.242
B	HEAD DIA.	.20	.25	.30	.35	.45
	ISO#	4	6	8	10	14

## SLOTTED PART NUMBER AND PRICE GUIDE

SIZE:	4		6		8		10		12		14	
LENGTH	PART#	\$	PART#	\$	PART#	\$	PART#	\$	PART#	\$	PART#	\$
1/4	2-1622	.09	2-1600	.14								
3/8			2-1605	.15	2-1626	.17	2-1630	.22				
1/2	2-1621	.13	2-1601	.15	2-1608	.18	2-1614	.23	2-1641	.29	2-1647	.38
5/8	2-1623	.14	2-1606	.17	2-1627	.19	2-1631	.24				
3/4			2-1602	.17	2-1609	.20	2-1615	.25	2-1642	.31	2-1640	.42
1			2-1603	.18	2-1610	.25	2-1616	.26	2-1643	.33	2-1648	.44
1 1/4							2-1617	.28			2-1637	.47
1 1/2			2-1604	.21	2-1612	.30	2-1618	.30	2-1645	.37	2-1649	.49
2							2-1619	.33	2-1646	.39		

## PHILLIPS PART NUMBER AND PRICE GUIDE

SIZE:	4		6		8		10		12		14	
LENGTH	PART#	\$	PART#	\$	PART#	\$	PART#	\$	PART#	\$	PART#	\$
1/4	2-1651	.04	2-1674	.05	2-1675	.08						
3/8	2-1652	.04	2-1670	.05	2-1660	.09	2-1687	.12				
1/2	2-1653	.04	2-1656	.05	2-1661	.09	2-1666	.13				
5/8			2-1695	.06							2-1692	.35
3/4	2-1654	.05	2-1657	.07	2-1662	.11	2-1667	.14	2-1690	.18	2-1693	.39
1			2-1658	.08	2-1663	.13	2-1668	.16	2-1691	.19	2-1679	.54
1 1/4					2-1697	.16	2-1698	.19				
1 1/2			2-1696	.12	2-1664	.18	2-1669	.21			2-1680	.89
1 3/4					2-1682	.19						
2					2-1683	.20	2-1672	.26				

SLOTTED ROUND PERSONAL ASSORTMENT: 1000 PIECES 3-3181 \$ 160.00

PHILLIPS ROUND PERSONAL ASSORTMENT: 1000 PIECES 3-3180 113.00

## ROUND WASHER (.36 O.D. FLANGE) HEAD - COMMONLY USED ON GLOVE BOX LINERS AND WHEEL WELL TRIM

- #8 X 3/8 # 2-1676 \$ .14
- #8 X 1/2 2-1677 .18\*
- #8 X 5/8 2-1684 .22
- #8 X 3/4 2-1685 .25
- #8 X 1 2-1686 .29

\*WHEEL WELL MOLDING TRIM SCREW KIT  
# 6-1796 SET OF 30 \$ 8.00

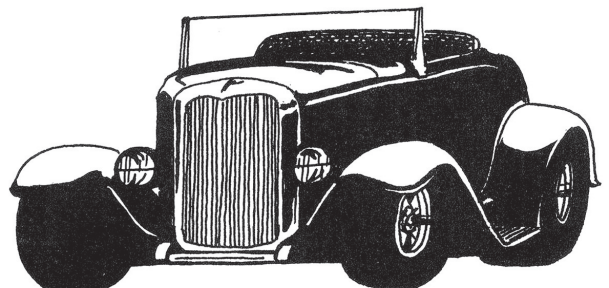

# TRUSS HEAD SHEET METAL SCREWS

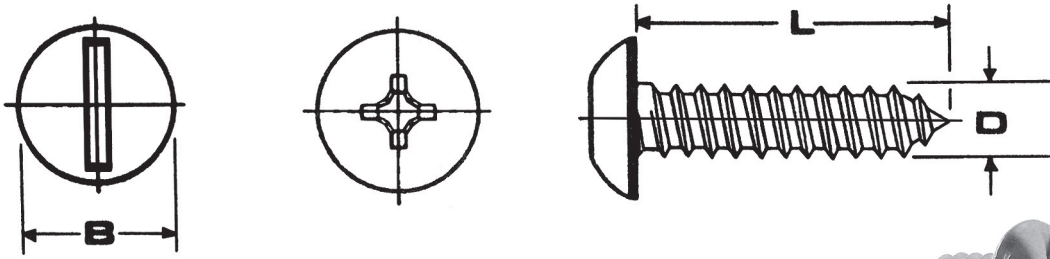

**DIMENSION TABLE (INCHES)**

D	DIAMETER	.112	.138	.164	.190	.216	.242
B	HEAD DIA.	.25	.31	.38	.43	.50	.55
	ISO#	4	6	8	10	12	14



**SLOTTED PART NUMBER AND PRICE GUIDE**

SIZE:	4		6		8		10		12		14	
LENGTH	PART#	\$	PART#	\$	PART#	\$	PART#	\$	PART#	\$	PART#	\$
1/4	2-1585	.06										
3/8	2-1586	.06	2-1550	.08	2-1558	.09	2-1566	.17				
1/2	2-1587	.07	2-1551	.08	2-1559	.09	2-1567	.18	2-1578	.24	2-1592	.32
5/8			2-1552	.09	2-1560	.10	2-1568	.19	2-1579	.25	2-1593	.34
3/4	2-1589	.08	2-1553	.10	2-1561	.11	2-1569	.20			2-1580	.36
1			2-1554	.11	2-1562	.12	2-1570	.21			2-1594	.38
1 1/4					2-1563	.15	2-1573	.23			2-1595	.43
1 1/2			2-1557	.16	2-1564	.19	2-1571	.26			2-1596	.48
2							2-1572	.29				

**PHILLIPS PART NUMBER AND PRICE GUIDE**

SIZE:	4		6		8		10		12		14	
LENGTH	PART#	\$	PART#	\$	PART#	\$	PART#	\$	PART#	\$	PART#	\$
1/4	2-1546	.04	2-1544	.05								
3/8	2-1501	.04	2-1507	.05	2-1515	.06	2-1523	.07				
1/2	2-1502	.05	2-1508	.05	2-1516	.08	2-1524	.09	2-1537	.17	2-1575	.19
5/8			2-1509	.06	2-1517	.13	2-1525	.14			2-1576	.24
3/4	2-1548	.05	2-1510	.07	2-1518	.14	2-1526	.15	2-1532	.19	2-1538	.28
1	2-1504	.05	2-1511	.08	2-1519	.15	2-1527	.16	2-1533	.21	2-1539	.33
1 1/4			2-1512	.08	2-1520	.16	2-1528	.17	2-1534	.23	2-1540	.39
1 1/2			2-1574	.09	2-1521	.18	2-1529	.19	2-1535	.25	2-1541	.45
1 3/4					2-1555	.20	2-1556	.21				
2					2-1522	.22	2-1530	.23	2-1536	.29	2-1542	.49

**SLOTTED TRUSS SHEET METAL SCREW SHOP ASSORTMENT:** 1210 PIECES # 3-3058 \$ 322.50  
**PERSONAL ASSORTMENT:** 1000 PIECES 3-3162 169.00  
**PHILLIPS TRUSS SHEET METAL SCREW SHOP ASSORTMENT:** 1210 PIECES 3-3026 193.00  
**PERSONAL ASSORTMENT:** 1000 PIECES 3-3160 125.00

**TRAILER SCREWS (SQUARE DRIVE):**

- #8 X 3/4 # 2-1514 \$ .14
- #8 X 1 2-1513 .16
- #8 X 1 1/2 2-1531 .19
- #10 X 3/4 2-1500 .19
- #10 X 1 2-1503 .21
- #10 x 1 1/2 2-1545 .37

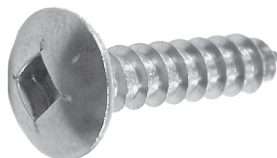

**SMALL HEAD TRUSS TRIM SCREWS:**

- #8 X 3/8 PHILLIPS JACKSON (#5 HEAD) # 2-1597 \$ .13
- #8 X 1/2 PHILLIPS JACKSON (#5 HEAD) 2-1598 .15





# PIPE FITTINGS - IN STOCK ITEMS

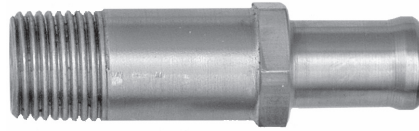

## PIPE NIPPLES - THREADED ON EACH END

SIZE:	1/8		1/4		3/8		1/2	
LENGTH	PART#	\$	PART#	\$	PART#	\$	PART#	\$
CLOSE*	7-0219	3.49	7-0229	3.88	7-0230	4.59	7-0231	5.38
1 1/2	7-0224	4.48	7-0232	4.76	7-0240	4.98	7-0262	6.24
2	7-0225	4.79	7-0234	5.23	7-0241	5.39	7-0263	6.24
3	7-0226	5.66	7-0236	6.77	7-0243	7.22	7-0265	8.38
4	7-0228	6.98	7-0238	7.69	7-0245	8.89	7-0267	10.49
5					7-0247	10.78	7-0269	12.38

\* CLOSE NIPPLES ARE FULLY THREADED NIPPLES

## PLAIN PIPE - NO THREADS

PART #	PIPE SIZE	\$ PER FOOT	PIPE ID	PIPE OD
7-0221	1/4	7.99	.37	.54
7-0222	3/8	9.98	.48	.67
7-0223	1/2	14.69	.59	.84

\*AVAILABLE IN LONGER LENGTHS - MADE TO ORDER

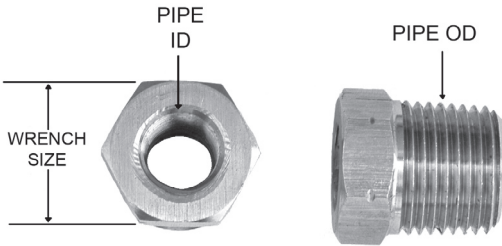
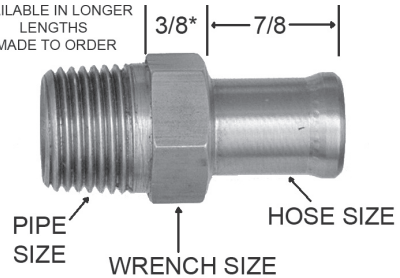

HOSE BARBS - 2" OVERALL LENGTH					
PART #	\$	WRENCH SIZE	HOSE SIZE	PIPE SIZE	LENGTH L
7-0314	25.66	3/4	5/8	3/8	7/8
7-0318	27.25	7/8	5/8	1/2	7/8
7-0319	27.25	7/8	3/4	1/2	7/8

HEX REDUCERS - IN STOCK ITEMS				
PART #	\$	WRENCH SIZE	PIPE ID	PIPE OD
7-0330	7.48	9/16	1/8	1/4
7-0331	8.69	3/4	1/8	3/8
7-0332	8.69	3/4	1/4	3/8
7-0333	11.32	7/8	1/8	1/2
7-0334	11.32	7/8	1/4	1/2
7-0335	11.32	7/8	3/8	1/2
7-0336	15.96	1 1/16	1/4	3/4
7-0337	15.96	1 1/16	3/8	3/4
7-0338	15.96	1 1/16	1/2	3/4

## OEM STYLE HOSE BARBS FOR PONTIACS - MADE TO ORDER

PART #	\$	WRENCH SIZE	HEX HEIGHT	HOSE SIZE	PIPE SIZE	OVERALL LENGTH
7-0345	28.98	7/8	.19	5/8	1/2	1.86
7-0347	29.99	7/8	.19	5/8	1/2	2.25
7-0375	30.50	7/8	.22	3/4	1/2	2.33



- PLACE YOUR FITTING ON THE CIRCLES TO CHECK FOR SIZE! -

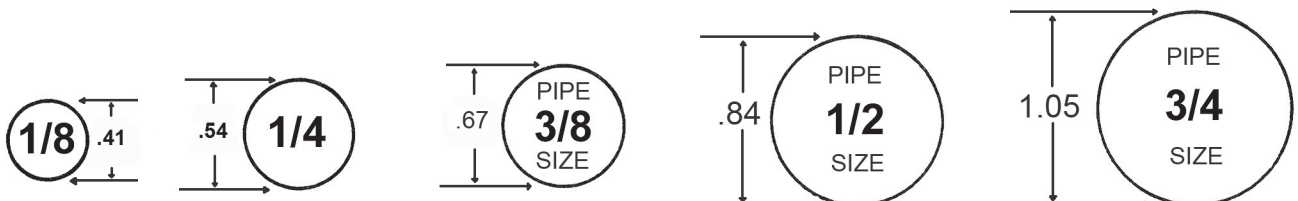

TOLL FREE ORDER LINE : 1-800-767-4781

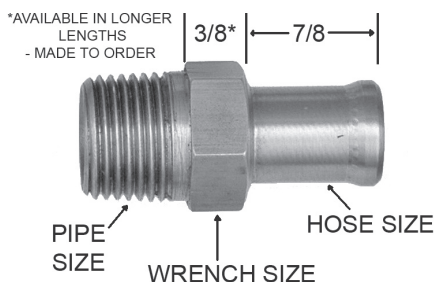

# SPECIALTY PIPE FITTINGS - MADE TO ORDER - NOT STOCK ITEMS

**MADE IN USA:  
WE MAKE ALL OF  
THESE IN OUR SHOP  
FROM 300 SERIES  
STAINLESS**



## SLOTTED END HOSE BARBS

1/4 NPT X 1/2 HOSE X 1 3/8"	# 7-0349	\$ 18.73
3/8 NPT X 5/8 HOSE X 1 3/8"	7-0350	25.68
3/8 NPT X 3/4 HOSE X 1 3/8"	7-0354	20.40
3/8 NPT X 5/8 HOSE X 3"	7-0351	20.94
1/2 NPT X 5/8 HOSE X 1 5/8"	7-0355	26.73
1/2 NPT X 3/4 HOSE X 1 5/8"	7-0352	26.77
1/2 NPT X 3/4 HOSE X 3"	7-0353	21.90

COMPACT HOSE BARBS					
PART #	\$	WRENCH SIZE	HOSE SIZE	PIPE SIZE	LENGTH L
7-0250	22.51	3/8	1/4	1/16	1/2
7-0251	24.10	7/16	1/8	1/8	1/2
7-0252	24.15	7/16	3/16	1/8	1/2
7-0253	23.98	7/16	1/4	1/8	5/8
7-0254	23.93	7/16	5/16	1/8	5/8
7-0255	23.88	7/16	3/8	1/8	5/8
7-0256	24.61	9/16	1/8	1/4	5/8
7-0257	24.55	9/16	3/16	1/4	5/8
7-0258	24.50	9/16	1/4	1/4	5/8
7-0259	24.44	9/16	5/16	1/4	5/8
7-0260	24.72	9/16	3/8	1/4	3/4
7-0261	24.66	9/16	1/2	1/4	3/4

HOSE BARBS					
PART #	\$	WRENCH SIZE	HOSE SIZE	PIPE SIZE	LENGTH L
7-0310	26.19	3/4	3/16	3/8	3/4
7-0311	26.10	3/4	1/4	3/8	7/8
7-0372	26.00	3/4	5/16	3/8	7/8
7-0312	25.87	3/4	3/8	3/8	7/8
7-0313	25.77	3/4	1/2	3/8	7/8
7-0314	25.66	3/4	5/8	3/8	7/8
7-0315	26.92	7/8	3/4	3/8	7/8
7-0322	27.24	7/8	1/4	1/2	7/8
7-0373	27.13	7/8	5/16	1/2	7/8
7-0316	27.00	7/8	3/8	1/2	7/8
7-0317	26.92	7/8	1/2	1/2	7/8
7-0318	27.25	7/8	5/8	1/2	7/8
7-0319	27.25	7/8	3/4	1/2	7/8

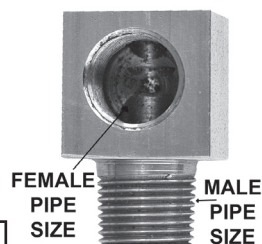
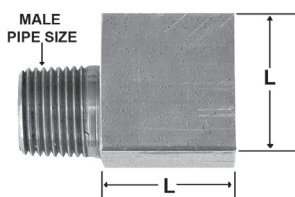

RIGHT ANGLE FITTINGS 90			
PART#	PIPE SIZE MALE/FEMALE	L	\$
7-0360	1/8 / 1/8	5/8	25.12
7-0364	1/4 / 1/8	5/8	25.72
7-0361	1/4 / 1/4	3/4	26.18
7-0362	3/8 / 1/4	3/4	25.87
7-0320	3/8 / 3/8	1	27.21
7-0321	1/2 / 3/8	1	26.82
7-0329	1/2 / 3/8	1 1/2	29.00

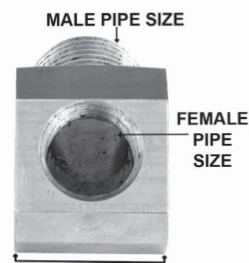
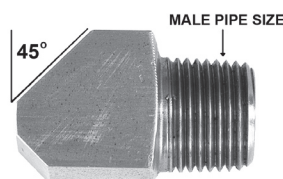

45 DEGREE FITTINGS			
PART#	PIPE SIZE MALE/FEMALE	L	\$
7-0325	1/8 / 1/8	5/8	26.10
7-0368	1/4 / 1/8	5/8	25.65
7-0327	1/4 / 1/4	3/4	27.76
7-0374	3/8 / 1/8	3/4	28.28
7-0369	3/8 / 1/4	3/4	27.84
7-0323	3/8 / 3/8	1	29.34
7-0324	1/2 / 3/8	1	28.78

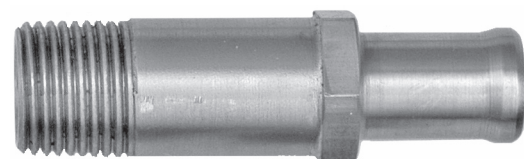

EXTENDED HOSE BARBS - 3" OVERALL LENGTH				
PART#	\$	WRENCH SIZE	HOSE SIZE	PIPE SIZE
7-0341	30.30	3/4	5/8	3/8
7-0342	32.33	7/8	3/4	3/8
7-0339	32.43	7/8	5/8	1/2
7-0340	32.75	7/8	3/4	1/2

AVAILABLE IN LONGER LENGTHS TO ORDER

**WE CUSTOM MAKE PARTS FROM BAR STOCK IF YOU  
NEED A SPECIALTY FITTING - WE CAN MAKE IT!**

# PIPE PLUGS

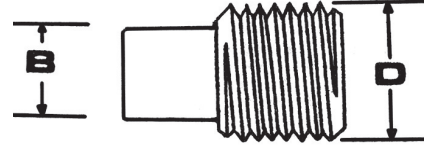
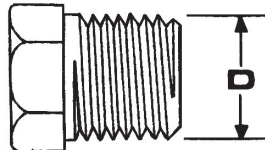
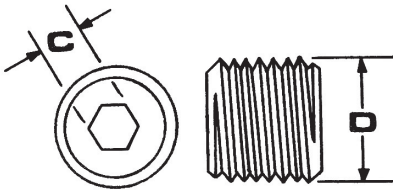

PIPE SIZE	HEX SOCKET			
	D	C	PART#	\$
1/8	.405	3/16	7-0100	1.95
1/4	.540	1/4	7-0101	1.95
3/8	.675	5/16	7-0102	1.95
1/2	.84	3/8	7-0103	2.50
3/4	1.05	9/16	7-0104	4.25
1	1.30	5/8	7-0105	9.25

PIPE SIZE	HEX HEAD			
	D	A	PART#	\$
1/8	.405	7/16	7-0106	2.25
1/4	.540	9/16	7-0107	3.50
3/8	.675	11/16	7-0108	5.25
1/2	.84	7/8	7-0109	9.25
3/4	1.05	1 1/8	7-0110	14.25

PIPE SIZE	SQUARE HEAD			
	D	B	PART#	\$
1/8	.405	9/32	7-0112	2.50
1/4	.540	3/8	7-0113	3.50
3/8	.675	7/16	7-0114	5.25
1/2	.84	9/16	7-0115	9.25
3/4	1.05	5/8	7-0116	15.25

**- PLACE YOUR PLUG ON THE CIRCLES TO CHECK FOR SIZE! -**

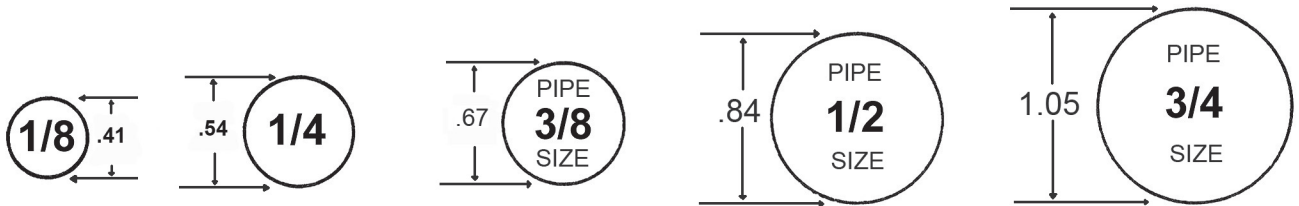

## OIL PAN & REAR END PLUGS

*CUSTOM MADE IN OUR SHOP!*



**OEM & CUSTOM STYLES:**  
**THE BUTTON HEADS LOOK GREAT & REDUCE THE CHANCE OF SNAGGING ON LOWERED VEHICLES AND 4 X 4'S**

### OIL & TRANSMISSION PAN PLUGS: SUPER LOW PROFILE!

1/2-20 TRUSS SOCKET HEAD (3/4" OD FLANGE)	# 7-0402	\$ 23.50
12-1.0 MM TRUSS SOCKET HEAD	1-6008	25.50

### PLUGS FOR DIFFERENTIALS:

<b>5/8-18: (1" OD FLANGE) (FOR SOME 9" FORD DIFFERENTIALS)</b>		
BUTTON HEAD	7-0403	27.50
SQUARE FLANGE HEAD	7-0404	37.50
<b>3/4-16: (1 1/8" OD FLANGE) (FOR SOME 9" FORD DIFFERENTIALS)</b>		
BUTTON HEAD	7-0405	30.50
SQUARE FLANGE HEAD	7-0406	45.50
<b>7/8-18 (1" OD FLANGE)</b>		
BUTTON HEAD	7-0414	27.50
<b>1-20 (1 3/8" OD FLANGE) FOR 1950'S GM CARS &amp; TRUCKS</b>		
BUTTON HEAD	7-0401	39.50
SQUARE FLANGE HEAD - ORIGINAL STYLE	7-0400	52.50
<b>16-1.5 MM PLUG</b>		
BUTTON HEAD (1" OD FLANGE)	7-0413	27.50
<b>22-1.5 MM PLUGS FOR GM 4X4 TRANSFER CASES</b>		
BUTTON HEAD (1 1/4" OD FLANGE)	7-0407	35.00
<b>1/2" STRAIGHT PIPE THREAD (1 1/4" OD FLANGE) (FOR '56-'66 BOP)</b>		
BUTTON HEAD	7-0409	39.50
SQUARE FLANGE HEAD - ORIGINAL STYLE	7-0410	50.50

## STAINLESS GREASE FITTINGS

SIZE:	A	B	C	X	PART#	\$
1/4-28 STRAIGHT	.54	.20	---	5/16	7-0054	2.50
1/4-28 45 DEGREE	.88	.20	.37	3/8	7-0055	6.50
1/4-28 90 DEGREE	.69	.20	.44	3/8	7-0056	6.50
1/8 NPT STRAIGHT	.62	.25	---	7/16	7-0050	3.99
1/8 NPT 45 DEGREE	.99	.27	.40	7/16	7-0051	9.95
1/8NPT 90 DEGREE	.82	.27	.47	7/16	7-0052	9.95

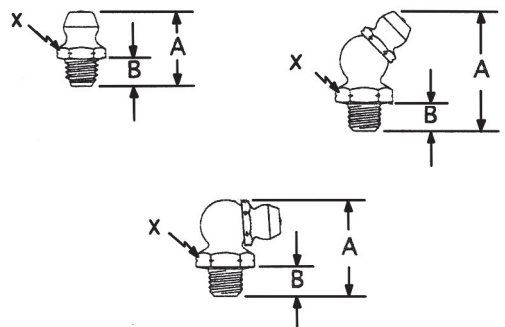

**HOSE CLAMPS**

**100% 300 SERIES STAINLESS  
MARINE GRADE**



**EXHAUST CLAMPS**

**HEAVY DUTY - 3/8 U-BOLTS  
MADE IN USA**



**\*\*AVAILABLE ELECTRO-POLISHED FOR ADDITIONAL  
CORROSION PROTECTION AND A BRILLANT APPEARANCE!\*\*  
- JUST ADD A "P" TO THE END OF THE PART#!**

SIZE:	PART#	\$
1 1/2	7-1002	11.95
1 3/4	7-1004	12.35
1 7/8	7-1005	12.80
2	7-1000	12.95
2 1/4	7-1001	13.95
2 1/2	7-1003	14.95
3	7-1006	16.95
3 1/2	7-1007	21.95
4	7-1008	24.95

PART#	DESCRIPTION	PLAIN	POLISHED
	<b>MIMI CLAMPS (5/16" WIDE)</b>		
7-0001	7/32" TO 5/8" (5.6 TO 16MM) I.D.	\$2.25	\$ 4.00
7-0003	7/16" TO 25/32" (11 TO 20MM) I.D.	2.30	4.25
7-0004	1/2" TO 29/32" (13 TO 23MM) I.D.	2.35	4.50
7-0005	9/16" TO 1 1/16" (14 TO 27MM) I.D.	2.40	4.75
	<b>STANDARD WIDTH (1/2" WIDE)</b>		
7-0006	1/2" TO 29/32" (13 TO 23MM) I.D.	3.00	5.50
7-0007	9/16" TO 1 1/16" (14 TO 27MM) I.D.	3.05	5.75
7-0015	11/16" TO 1 1/4" (17.5 TO 32MM) I.D.	3.10	6.00
7-0008	13/16" TO 1 1/2" (21 TO 38MM) I.D.	3.15	6.80
7-0010	1 1/16" TO 2" (27 TO 51MM) I.D.	3.20	7.25
7-0002	1 5/16" TO 2 1/4" (33 TO 57MM) I.D.	3.25	7.75
7-0011	1 9/16" TO 2 1/2" (40 TO 64MM) I.D.	3.50	8.25
7-0009	1 13/16" TO 2 3/4" (46 TO 70MM) I.D.	4.35	9.25
7-0012	2 1/16" TO 3" (52 TO 76MM) I.D.	4.50	9.75
7-0013	2 9/16" TO 3 1/2" (65 TO 89MM) I.D.	4.90	10.50
7-0014	2 13/16" TO 3 3/4" (71 TO 95MM) I.D.	5.00	11.00
7-0016	3 1/16" TO 4" (78 TO 102MM) I.D.	5.10	11.75
7-0017	3 9/16" TO 4 1/2" (91 TO 114MM) I.D.	5.25	12.50
7-0018	4 1/8" TO 5" (105 TO 127MM) I.D.	5.35	13.25
7-0019	4 5/8" TO 5 1/2" (117 TO 140MM) I.D.	5.50	13.75
7-0020	5 1/8" TO 6" (130 TO 152MM) I.D.	5.90	14.25
7-0021	5 5/8" TO 8 1/2" (142 TO 215MM) I.D.	7.50	
	<b>- HOSE CLAMP SETS -</b>	<b>PLAIN</b>	<b>POLISHED</b>
7-0040	V-8 SET - FUEL LINE, RADIATOR & HEATER HOSES (10 PC.)	25.50	57.50
7-0041	VW SET - FOR BUGS, BUSES AND GHIAS (10 PIECES)	25.50	57.50

**- FOR POLISHED HOSE CLAMPS ADD  
A "P" TO THE PART NUMBER -**



# SNAP FASTENERS

- GREAT FOR CONVERTIBLE TOPS, BOAT TARPS, ETC. -



CAP # 2-6000 \$.29 EACH



SOCKET # 2-6001 \$.29 EACH



STUD # 2-6002 \$.13 EACH



POST # 2-6003 \$.13 EACH

- USE WITH #8 JACKSON  
OVAL HEAD SCREWS

## E-STYLE RETAINING RINGS

15-7 PH - MO STAINLESS

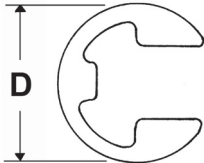

SIZE	D	T	GROOVE WIDTH	GROOVE DIAMETER	PART#	\$
3/16	.335	.025	.029	.147	2-5903	.39
1/4	.527	.025	.029	.210	2-5905	.48
5/16	.50	.025	.029	.250	2-5906	.48
3/8	.66	.035	.039	.303	2-5907	.76

## WIRE ROPE (CABLE) & SLEEVES

302 SS - 19 STRAND (GOOD FLEXIBILITY)

SIZE	PART#	\$/FT	BREAKING STRENGTH	PART# (SLEEVE)	\$
1/32	7-3000	.39	185 LB	7-3010	1.90
1/16	7-3002	.63			
3/32	7-3004	.78			
1/8	7-3005	.97	2100 LB	7-3014	2.90

## DOME HEAD OPEN ENDED TUBULAR RIVETS

- 100% 300 SERIES STAINLESS STEEL RIVETS - MADE IN USA -

GRIP RANGE	1/8" DIA.		5/32" DIA.		3/16" DIA.	
	PART#	\$	PART#	\$	PART#	\$
0 - 1/8"	2-4801	.19			2-4806	.29
1/8 - 1/4"	2-4803	.21	2-4805	.27	2-4800	.34
1/4 - 3/8"	2-4802	.25			2-4807	.36
3/8 - 1/2"	2-4804	.27			2-4808	.39



## LAG BOLTS

GREAT FOR MARINE USE OR  
BUILDING THE PERFECT DECK!

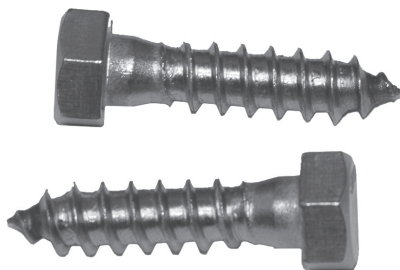

SIZE:	1/4		5/16		3/8		1/2	
LENGTH	PART#	\$	PART#	\$	PART#	\$	PART#	\$
1	2-1830	.33	2-1810	.39	2-1820	.59		
1 1/4	2-1831	.35	2-1811	.41	2-1821	.61		
1 1/2	2-1803	.38	2-1812	.43	2-1822	.63	2-9839	1.26
1 3/4	2-9816	.39	2-9819	.45				
2	2-1804	.42	2-1813	.47	2-1823	.67	2-1843	1.39
2 1/2	2-1832	.49	2-1842	.49	2-1824	.69	2-9840	1.55
2 3/4					2-9829	.89		
3	2-1833	.55	2-1841	.59	2-1825	.98	2-1836	1.69
3 1/2	2-1807	.67	2-1814	.99	2-1826	1.20	2-1837	1.86
4	2-1834	.77	2-1815	1.22	2-1827	1.25	2-1838	1.98
4 1/2	2-9817	.82	2-9826	1.33	2-9830	1.34	2-9841	2.46
5	2-1849	.87	2-1816	1.46	2-1828	1.43	2-9842	2.90
5 1/2	2-9818	.93	2-9828	1.57	2-9832	1.69	2-9843	3.27
6	2-1840	.98	2-1835	1.68	2-1829	1.98	2-9844	3.60
8					2-9831	9.80	2-9846	15.95



# CLEVIS & COTTER PINS

## HAIRPIN COTTERS

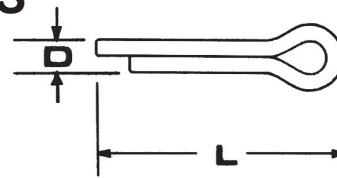

PART NUMBER AND PRICE GUIDE

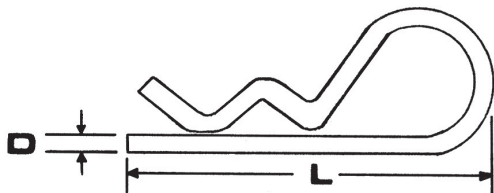

D	L	FOR SHAFT SIZES	EYE ID	PART#	\$
.042	1	3/16 - 1/4	1/4	2-5050	.25
.062	13/16	1/4 - 3/8	5/16	2-5051	.29
.073	1 7/8	3/8 - 1/2	5/8	2-5052	.37
.092	2	3/8 - 5/8	5/8	2-5053	.59
.125	2 9/16	7/16 - 3/4	9/16	2-5054	.97

SIZE:	3/64		1/16		3/32		1/8	
LENGTH	PART#	\$	PART#	\$	PART#	\$	PART#	\$
3/8			2-5019	.04				
1/2	2-5040	.05	2-5000	.05	2-5006	.06	2-5012	.09
5/8	2-5041	.06	2-5047	.05	2-5081	.07	2-5084	.10
3/4	2-5042	.06	2-5001	.05	2-5007	.07	2-5013	.11
1	2-5043	.06	2-5002	.06	2-5008	.08	2-5014	.13
1 1/4	2-5044	.07	2-5003	.06	2-5009	.09	2-5015	.15
1 1/2	2-5045	.07	2-5004	.07	2-5010	.10	2-5016	.16
1 3/4			2-5048	.08	2-5082	.10	2-5085	.17
2	2-5046	.09	2-5005	.09	2-5011	.11	2-5017	.18
2 1/2					2-5083	.15		
3							2-5018	.21

SMALL EYE I.D. COTTER PINS					
D	L	FOR SHAFT SIZES	EYE ID	PART#	\$
.047	19/32	1/8-3/16	1/8	2-5070	.23
.054	3/4	3/16-1/4	1/8	2-5071	.34
.080	1 3/16	1/4-3/8	1/4	2-5072	.43
.093	1 5/8	1/4-1/2	3/8	2-5073	.55

SIZE:	5/32		3/16		1/4	
LENGTH	PART#	\$	PART#	\$	PART#	\$
3/4	2-5020	.16	2-5026	.25		
1	2-5021	.18	2-5027	.27	2-5033	.65
1 1/4	2-5022	.20	2-5028	.29	2-5034	.75
1 1/2	2-5023	.21	2-5029	.34	2-5035	.85
1 3/4	2-5086	.23	2-5089	.37	2-5038	.95
2	2-5024	.25	2-5030	.39	2-5036	1.15
2 1/2			2-5090	.42		
3	2-5025	.29	2-5031	.45	2-5037	1.25
4	2-5088	.49	2-5032	.68		

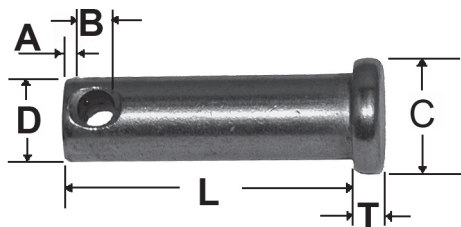

DIMENSION TABLE (INCHES)

D	DIAMETER	1/4	5/16	3/8	1/2
A	END TO HOLE	.14	.21	.23	.23
B	HOLE SIZE	3/32	5/32	5/32	5/32
C	HEAD DIAMETER	3/8	7/16	1/2	5/8
T	HEAD THICKNESS	.09	.09	.12	.15
	SHEAR STRENGTH -LBS	1,500	2,500	3,700	6,500

PERSONAL ASSORTMENT: 1000 PIECES 18 SIZES  
 1/16 X 1/2 THROUGH 3/16 X 1 1/2 3-3140 119.00  
 SHOP ASSORTMENT: 2175 PIECES 24 SIZES:  
 1/16 X 1/2 THROUGH 1/4 X 1 1/4 3-3038 240.50

## HAIRPIN CLIPS

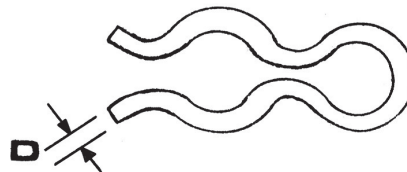

L: LENGTH PART NUMBER AND PRICE GUIDE

SIZE:	1/4		5/16		3/8		1/2	
L	PART#	\$	PART#	\$	PART#	\$	PART#	\$
3/4	2-9003	1.30	2-9022	2.40	2-9041	3.55		
1	2-9005	1.40	2-9024	2.50	2-9043	3.70	2-9076	6.30
1 1/4	2-9006	1.50	2-9025	2.60			2-9077	6.45
1 1/2	2-9007	1.60	2-9026	2.70	2-9045	4.10	2-9078	6.60
1 3/4	2-9008	1.75	2-9027	2.80	2-9046	4.45	2-9079	6.75
2	2-9009	1.90	2-9028	2.90	2-9047	4.80	2-9080	6.90
2 1/4			2-9031	3.20	2-9050	4.98		
2 1/2			2-9032	3.40	2-9051	5.34		

D	SHAFT SIZE	GROOVE DIA.	PART#	\$
.029	1/8	5/64	2-5059	.19
.031	3/16	9/64	2-5060	.19
.048	5/16	1/4	2-5062	.26
.052	3/8	5/16	2-5063	.29
.055	7/16	3/8	2-5064	.34
.064	1/2	7/16	2-5065	.59
.087	5/8	17/32	2-5066	.89
.093	3/4	21/32	2-5067	.98

# POLISHING SUPPLIES - ALL MADE IN USA

- BASIC POLISHING KITS** - 6" SEWN & LOOSE BUFFS AND (2) 1 LB. BARS (1) OF EACH COMPOUND # 3-2000 \$ 65.75  
 6" SEWN & LOOSE BUFFS AND (2) 1 LB. BARS OF WHITE COMPOUND 3-2003 66.50  
 8" SEWN & LOOSE BUFFS AND (3) 1 LB. BARS OF COMPOUND 3-2001 83.50  
 (2) BARS OF WHITE COMPOUND & (1) OF GRAY COMPOUND

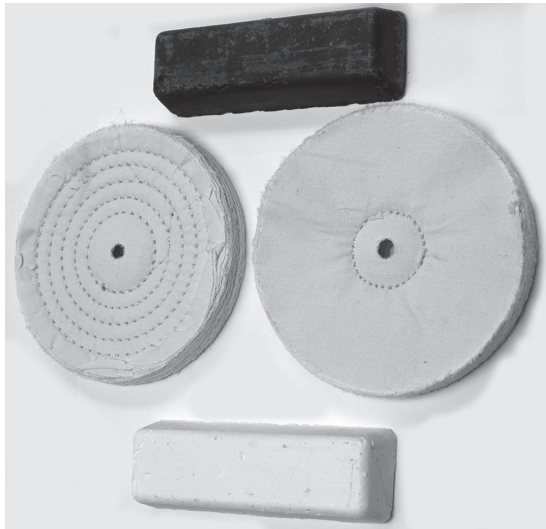

**INDIVIDUAL COMPONENTS:**

- GRAY COMPOUND (CUTTING)**  
 1 LB. BAR # 3-2020 \$11.50  
 3 LB. BAR 3-2023 21.50  
**WHITE COMPOUND (COLORING)**  
 1 LB. BAR 3-2021 12.75  
 3 LB. BAR 3-2024 22.75  
**SEWN BUFFS - 3/4" THICK**  
 6" DIAMETER 3-2010 19.75  
 8" DIAMETER 3-2012 24.75  
**LOOSE BUFFS - 1" THICK**  
 6" DIAMETER 3-2011 19.75  
 8" DIAMETER 3-2013 24.75

\*THESE ARE THE BEST BUFFS WE'VE FOUND & WE'VE USED A LOT OF BUFFS! THEY LAST LONGER AND ARE LESS PRONE TO THROWING OFF LOOSE STRINGS.\*

**U.S. FASTENER HOLDER SET # 3-2050 \$ 85.75**

- SET CONTAINS 4 TOOLS: A TAPERED TOOL FOR WASHERS, 3 TOOLS (1/4-20, 5/16-18, & 3/8-16) FOR HOLDING NUTS AND BOLTS. THIS SET IS ALL THAT IS NEEDED FOR A TYPICAL U.S. ENGINE KIT.

\*\* NOTE: FOR SAFETY, FASTENERS HOLDERS ARE A MUST!

**METRIC FASTENER HOLDER SET # 3-2049 \$ 87.00**

-SET CONTAINS 4 TOOLS: A TAPERED TOOL FOR WASHERS, 3 TOOLS (6MM, 8MM, & 10MM) FOR HOLDING NUTS AND BOLTS

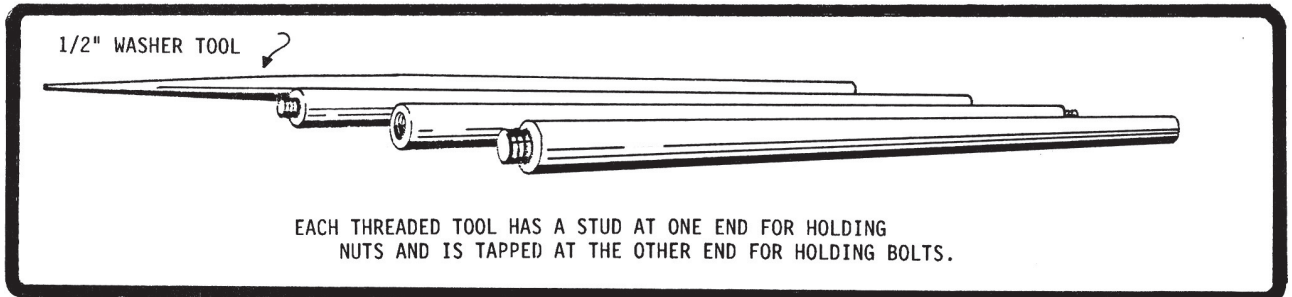

**INDIVIDUAL TOOLS:**

- WASHER TOOLS: 1/2" DIAMETER # 3-2069 \$ 21.75

3/4" DIAMETER # 3-2070 \$ 32.75

**THREADED TOOLS:**

- COARSE THREAD -		
SIZE	PART#	\$
6-32	3-2054	19.75
8-32	3-2055	19.75
10-24	3-2056	19.75
1/4-20	3-2052	21.50
5/16-18	3-2051	22.50
3/8-16	3-2053	23.00
7/16-14	3-2060	25.00
1/2-13	3-2061	26.00

- FINE THREAD -		
SIZE	PART#	\$
10-32	3-2071	19.75
1/4-28	3-2057	21.50
5/16-24	3-2058	22.50
3/8-24	3-2059	23.00
7/16-20	3-2072	25.00
1/2-20	3-2062	26.00

- METRIC THREAD -		
SIZE	PART#	\$
3-0.5	3-2063	20.50
4-0.7	3-2064	20.50
5-0.8	3-2065	22.00
6-1.00	3-2066	22.00
8-1.25	3-2067	22.00
10-1.5	3-2068	23.50
12-1.75	3-2073	25.50



**GRIT FLAP WHEELS**

-IDEAL FOR TAKING OFF DEEP SCRATCHES AND MANUFACTURING MARKS. 320 GRIT FLAP WHEELS PRODUCE A SMOOTH FINISH - READY FOR BUFFING. WHEELS WITH COARSER GRIT (180,120, ETC.) PRODUCE SCRATCHES THAT BUFFS AND COMPOUND CAN'T REMOVE. FLAP WHEELS NORMALLY OUTLAST BUFFING WHEELS BY 4 TIMES.

- 320 GRIT ABRASIVE FLAP WHEELS**  
 6" DIA. X 1" WIDE # 3-2100 \$ 50.00  
 8" DIX. X 1" WIDE 3-2101 85.00

**MASTER POLISHING KIT: INCLUDES POLISHING KIT, FLAP WHEEL, & U.S. FASTENER HOLDER SET**

- 6" WHEELS # 3-2006 \$ 210.00  
 - 8" WHEELS 3-2008 270.00

# POINT OF PURCHASE DISPLAYS



**20 PACKS OF TOTAL-LOC HEADER BOLTS  
(10) OF BOTH 12 & 16 COUNT  
# 8-0001**



**EXAMPLE OF A PIPE PLUG PACKAGE**



## STANDING DISPLAY

**4 SIDED ISLAND WITH 250  
\$10 PACKAGES OF:**

- BUTTON HEAD,
  - HOSE CLAMPS,
  - PHILLIPS PAN,
  - PHILLIPS OVAL,
  - CARRIAGE,
  - TRUSS HEAD,
  - NUTS,
  - LOCK NUTS,
  - LOCK WASHERS,
  - & WASHERS
- # 8-0400

**WE MAKE 100'S OF UNIQUE PACKS  
OF STAINLESS PRODUCTS**

**CALL 1-800-767-4781 OR  
1-717-677-8811 OUTSIDE USA  
FOR PRICING**



1945 HEIDLEBURG RD  
 ASPERS, PA 17304  
 1-800-767-4781  
 717-677-8811  
 FAX: 717-677-4525



CUSTOMER ID#		[ ] HOME [ ] BUSINESS		*PLEASE CHECK APPROPRIATE BOX*		[ ] HOME [ ] BUSINESS		46			
NAME:				NAME:							
SHIPPING ADDRESS:				MAILING / BILLING ADDRESS:							
CITY		STATE		ZIP		CITY		STATE		ZIP	
PHONE (DAY):				PHONE (EVENING):							
MAKE OF VEHICLE			MODEL			YEAR		ENGINE SIZE			
BILLING ADDRESS		[ ] SAME AS SHIPPING ADDRESS		*PLEASE CHECK APPROPRIATE BOX*		[ ] SAME AS MAILING ADDRESS					

QTY	PART #	DESCRIPTION	PG #	EACH	TOTAL
* MINIMUM FOR EACH ITEM IS \$1.95 RETAIL OR \$3.95 WHOLESALE *					
1					
2					
3					
4					
5					
6					
7					
8					
9					
10					
11					
12					
13					
14					
15					
16					
17					
18					
19					
20					
21					
22					
23					

\* \* WHEN PURCHASING ANY 7/16(10MM) OR LARGER LOW STRENGTH BOLTS, STATE THE APPLICATION! \*

NOTE: MINIMUM ORDER FOR RETAIL IS \$19.95, WHOLESALE IS \$39.95		TOTAL:
CREDIT CARD# _____	SECURITY CODE _____	SHIPPING/HANDLING:
EXP _____		COD CHARGE \$20.00:
CARDHOLDER'S SIGNATURE _____		SALES TAX: 6% PA RESIDENTS ONLY:
		TOTAL DUE:

SHIPPING/HANDLING: \$19.95-69: \$9.95 \$70-109: \$10.95 \$110-129: \$11.95 \$130-149: \$12.95  
 \$150-169: \$13.95 \$170-189: \$14.95 \$190-209: \$15.95 \$210-229: \$16.95 \$230-249: \$17.95 \$250-299: \$18.95 \$300-399: \$19.95  
 \$400-499: \$21.95 \$500-599: \$23.95 \$600-699: \$25.95 \$700-799: \$27.95 \$800-899: \$29.95 \$900-999: \$31.95 \$1000 UP: \$33.95  
 -SHIPMENTS OUTSIDE THE CONTINENTAL U.S. CAN BE SENT BY PRIORITY MAIL OR UPS - SHIPPING IS \$5 PLUS POSTAGE -









